Data Book

T_tAVDX_1119_IT - HFC R410A

t-AV DX

7-149 kW

Direct expansion air conditioners for IT Cooling.
To be matched with remote air-cooled condenser.



The picture of the unit is indicative and may vary depending on the model



- Perimeter installation
- Fully hermetic ON/OFF compressors
- Single or double refrigerant circuit
- Air delivery from the bottom or from the top

- Plug fans with EC electric motor
- Electronic expansion valve
- Air suction temperature up to 40°C

INDEX

CERTIFICATIONS	4
GENERAL CHARACTERISTICS	5
INSTALLATION	6
PRODUCT FEATURES AND BENEFITS	6
F-GAS DIRECTIVE	6
MODEL IDENTIFICATION	7
TRANSPORT AND STORAGE TEMPERATURE	7
WORKING LIMITS	8
MAIN COMPONENTS	9
REMOTE AIR-COOLED CONDENSERS	11
OPTIONAL ACCESSORIES	11
TECHNICAL DATA	14
REFRIGERANT CHARGE	19
PRESSURE RELIEF VALVE	20
REFRIGERANT CIRCUIT	21
RECOMMENDED REFRIGERANT LINES	23
“SI” INTERNATIONAL SYSTEM PIPES DIAMETERS	23
“IMPERIAL” SYSTEM PIPES DIAMETERS	24
INSTALLATION DIAGRAM	25
ACOUSTIC DATA	26
ELECTRICAL DATA	27
MICROPROCESSOR CONTROL SYSTEM	28
DEMAND LIMIT	30
TEMPERATURE PROBE ON AIR RETURN / DELIVERY	30
CLOGGED FILTERS SENSOR	30
FLOOD SENSOR	30
POSSIBLE AIR INTAKE FOR OVER VERSIONS	31
REMOTE AIR-COOLED CONDENSER	32
OPTIONAL ACCESSORIES: P121 – FRONT AIR INTAKE+BOTTOM PANEL	33
OPTIONAL ACCESSORIES: P122 - BOTTOM AIR INTAKE+BLIND PANELS	33
OPTIONAL ACCESSORIES: 601 – SOLENOID VALVE ON LIQUID LINE	33
OPTIONAL ACCESSORIES: A548 - CONSTANT PREVALENCE	34
OPTIONAL ACCESSORIES: P091 - BACK-UP MODULE CONTROLLER	34
OPTIONAL ACCESSORIES: P171 – KIT FOR AIR -45°C MCH AXIAL AC	34
OPTIONAL ACCESSORIES: P172 – KIT FOR AIR -45°C AXIAL AC	34
OPTIONAL ACCESSORIES: P191 – POWER SUPPLY FOR CONDENSER	35
OPTIONAL ACCESSORIES: 383 – NUMBERED WIRINGS + UK REQUESTS	35
OPTIONAL ACCESSORIES: 4181 – SERIAL CARD MODBUS	35
OPTIONAL ACCESSORIES: 4182 – SERIAL CARD LON	36
OPTIONAL ACCESSORIES: 4184 – SERIAL CARD BACNET MS/TP RS485	36
OPTIONAL ACCESSORIES: 4185 – SERIAL CARD BACNET OVER IP	36
OPTIONAL ACCESSORIES: A492 – WATER LEACKAGE DETECTOR + ADDITIONAL DETECTOR	36
OPTIONAL ACCESSORIES: A511 - SMOKE DETECTORS	36
OPTIONAL ACCESSORIES: A521 – FIRE DETECTORS	36
OPTIONAL ACCESSORIES: P141 – ANALOGUE SET-POINT COMPENSATION	37
OPTIONAL ACCESSORIES: P181 – NETWORK ANALYZER	37
OPTIONAL ACCESSORIES: P182 – NETWORK ANALYZER+OPTIONAL	37
OPTIONAL ACCESSORIES: P183 – KIT NETWORK ANALYZER	37
OPTIONAL ACCESSORIES: P184 – KIT NETWORK ANALYZER+OPTIONAL	37
OPTIONAL ACCESSORIES: A812 – FREE-COOLING DIRECT CONTROL	38
OPTIONAL ACCESSORIES: P131 – HOT WATER COIL+2WAY VALVE	39
OPTIONAL ACCESSORIES: P211 - HOT GAS HEATING+4WAY VALVE	44

OPTIONAL ACCESSORIES: A431 – ELECTRIC HEATERS	46
OPTIONAL ACCESSORIES: A432 – EXTRA POWER ELECTRIC HEATERS	46
OPTIONAL ACCESSORIES: 4301 – STEAM HUMIDIFIER 3KG/H	48
OPTIONAL ACCESSORIES: 4303 – STEAM HUMIDIFIER 8KG/H	48
OPTIONAL ACCESSORIES: 4305 – STEAM HUMIDIFIER 15KG/H	48
OPTIONAL ACCESSORIES : P051 – DEHUMIDIFICATION FUNCTION	51
OPTIONAL ACCESSORIES: P161 - T/RH AIR INTAKE SENSOR	51
OPTIONAL ACCESSORIES: P071 - REMOTE T/RH PROBE	51
OPTIONAL ACCESSORIES: 4666 – EXTERNAL AIR PROBE	51
OPTIONAL ACCESSORIES: P111 – DUAL POWER SUPPLY	52
OPTIONAL ACCESSORIES: P112 – DUAL POWER SUPPLY + OPTIONAL	52
OPTIONAL ACCESSORIES: P113 – KIT DUAL POWER SUPPLY	52
OPTIONAL ACCESSORIES: P114 – KIT DUAL POWER SUPPLY + OPTIONAL	52
OPTIONAL ACCESSORIES: A381 - DRAIN PUMP	53
OPTIONAL ACCESSORIES: P084 – AIR FILTER EPM ₁₀ 50%	54
OPTIONAL ACCESSORIES: A531 – ON-OFF DAMPER	55
OPTIONAL ACCESSORIES: P011 - EMPTY PLENUM	57
OPTIONAL ACCESSORIES: P012 - EMPTY PLENUM CL.A1	57
OPTIONAL ACCESSORIES: P031 - EMPTY INTAKE PLENUM	57
OPTIONAL ACCESSORIES: P032 - EMPTY INTAKE PLENUM CL.A1	57
OPTIONAL ACCESSORIES: P013 - PLENUM + 3 GRILLES	57
OPTIONAL ACCESSORIES: P014 - PLENUM + 3 GRILLES CL.A1	57
OPTIONAL ACCESSORIES: P015 - SILENCED PLENUM	57
OPTIONAL ACCESSORIES: P016 - SILENCED PLENUM + 1 GRILLE	57
OPTIONAL ACCESSORIES: P017 - PLENUM + FILTER EPM2.5 50%	57
OPTIONAL ACCESSORIES: P018 - PLENUM + FILTER EPM1 50%	57
OPTIONAL ACCESSORIES: P019 - PLENUM + FILTER EPM1 85%	57
OPTIONAL ACCESSORIES: P034 – INTAKE FREE-COOLING PLENUM	64
OPTIONAL ACCESSORIES: P041 – SUPPORT FRAME H 255-350MM	68
OPTIONAL ACCESSORIES: P042 – SUPPORT FRAME H 355-450MM	68
OPTIONAL ACCESSORIES: P043 – SUPPORT FRAME H 400-510MM	68
OPTIONAL ACCESSORIES: 3601 – COMPRESSOR OPERATING SIGNAL CONTACT	68
OPTIONAL ACCESSORIES: 2411 – PHASE SEQUENCE RELAY	69
OPTIONAL ACCESSORIES: 1511 – SOFT STARTER	69
OPTIONAL ACCESSORIES: 3301 – COMPRESSOR REPHASING	70
OPTIONAL ACCESSORIES: A181 – COMPRESSOR SOUNDPROOF JACKET	70
OPTIONAL ACCESSORIES: A272 – CL.0 OR A1 (EN13501-1) INSULATION	70
OPTIONAL ACCESSORIES: P151 – LOWERED DISPLAY FOR UNDER	70
MACHINE DRAWINGS	71
HOLE IN THE RAISED FLOOR FOR DOWNFLOW VERSION	90
EXAMPLE FOR MACHINES NOISE EMISSION CALCULATION	91
AIR FILTERS REPLACEMENT	93
SHIPMENT: PACKING DIMENSIONS	94
SHIPMENT: SHIPPING WEIGHT	94
SHIPMENT: OPTIONALS PACKING DIMENSIONS AND SHIPPING WEIGHT	95

Liability disclaimer

The present publication is drawn up by of information only and does not constitute an offer binding upon Mitsubishi Electric Hydronics & IT Cooling Systems S.p.A. Mitsubishi Electric Hydronics & IT Cooling Systems S.p.A. has compiled the content of this publication to the best of its knowledge. The data contained herein are subject to change without notice. Mitsubishi Electric Hydronics & IT Cooling Systems S.p.A. explicitly rejects any liability for any direct or indirect damage, in the broadest sense, arising from or related to the use and/or interpretation of this publication. All content is copyrighted by Mitsubishi Electric Hydronics & IT Cooling Systems S.p.A.

CERTIFICATIONS

SYSTEM CERTIFICATIONS



ISO 9001 CERTIFICATION
Quality Management System



ISO 14001 CERTIFICATION
Environmental Management System



BS OHSAS 18001 CERTIFICATION
Occupational Health and Safety Management System

PRODUCT CERTIFICATIONS BY COUNTRY



CE MARKING



CCC – CQC CERTIFICATION
(People's Republic of China)



EAC CERTIFICATION
(Russian Federation, Belarus, Kazakhstan)



GENERAL CHARACTERISTICS



UNDER
Downflow air delivery



OVER
Upflow air delivery

Air cooled direct expansion air conditioners for IT Cooling for matching with remote air cooled condenser. This series is offered in 22 models available in the following versions:

- The upflow version (Over) is characterized by air intake from the front through honeycomb grille and air delivery from the top of the unit.
- The downflow version (Under) is characterized by air intake from the top and air delivery from the bottom of the unit.

Cooling capacity: 7 ÷ 149 kW

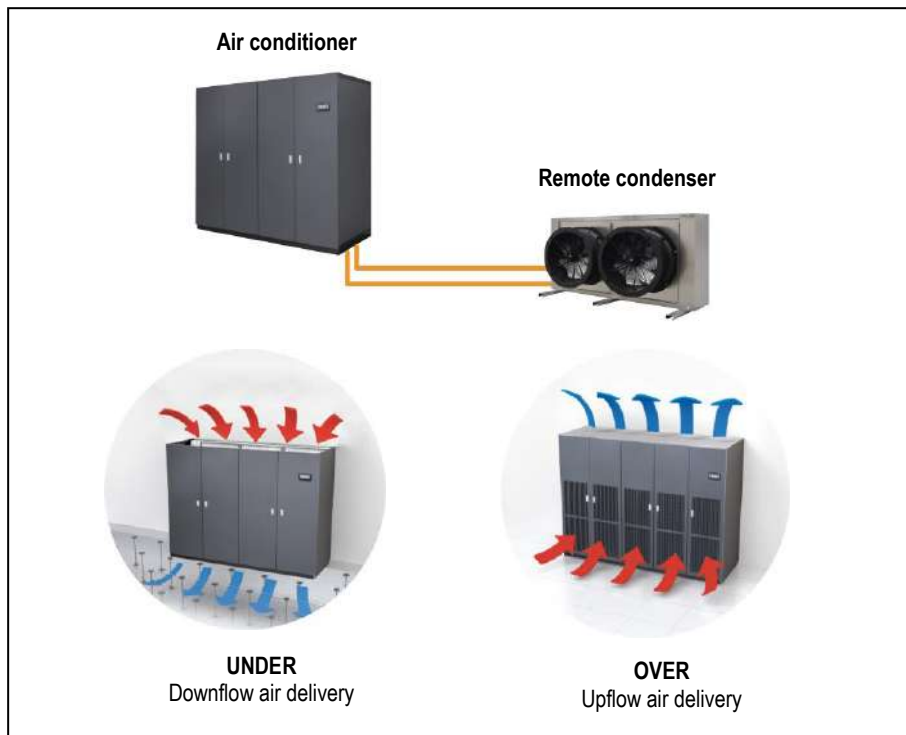

The machines are made for indoor installation.

The constructive solutions and the internal lay-out allow high application flexibility and the frontal access to the main components for the inspection and routine maintenance.

The installation requires refrigerant charge, electrical and hydraulic connections.

Final assembly on all machines before shipment including running test, reading and monitoring of operating parameters, alarms simulation and visual check.



INSTALLATION

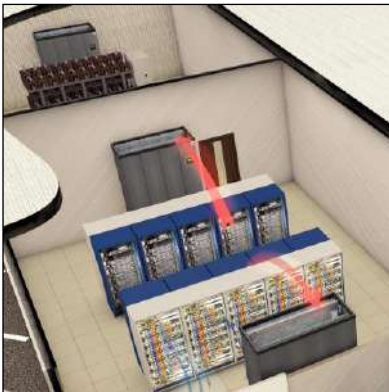
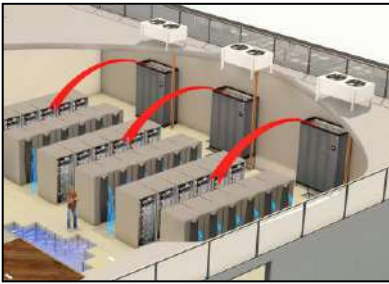

The series is particularly suitable for installation in Data Center of medium / small size with constant load.

DOWNFLOW VERSION (Under)

Typical installation is on the perimeter.

The units are placed along the perimeter of the Data Center. Air suction from the top of the unit and air delivery in the underfloor void.

The air distribution is achieved by special tiles placed in front of the racks row, forming cold aisle for air diffusion. On the rear of the racks is expelled the hot then aspirated by the unit.

For an optimal installation is advisable to provide the cold aisle containment.



Some solutions provide a service corridor around the server rooms where to place the units. In this case, it is necessary to provide the air intake plenum for each unit. With this solution, all the space in the Data Center is available for the installation of racks.

UPFLOW VERSION (Over)

The type of installation is practically like the previous. The only difference is that for the air distribution in the Data Center is not used the raised floor but ducts in the ceiling.



The series is also suitable for installation in UPS, Batteries, Distribution rooms and in all service areas of the Data Center that need a service of conditioning.

OPTIONAL

An extensive list of accessories allows the unit to adapt effectively to the real needs of the system, reducing the time and cost of installation.

PRODUCT FEATURES AND BENEFITS

- EER up to 4,49;
- New plug fans with EC electric motors and impeller in composite material, which guarantees a reduction of power consumption;
- Electronic expansion valve
- New fans electric motor that do not require maintenance;
- Improvement of the control software with advanced control logic;
- Single or double refrigerant circuit;
- Air suction temperature up to 40°C

F-GAS DIRECTIVE

The units highlighted in this publication contain <HFC R410A [GWP₁₀₀ 2088]> fluorinated greenhouse gases.

MODEL IDENTIFICATION

Air conditioners for IT Cooling

model: t-AV DX O 041 P1 S E4

t-AV	Series
DX	Unit type DX – direct expansion, air cooled
O	Air delivery O = over – upflow air delivery U = under – downflow air delivery
041	Model / Cooling capacity (kW) at nominal conditions
P1	Compressor type and number P = scroll compressor for R410A 1 = number of compressors
S	Refrigerant circuit S = single D = double
E4	Size

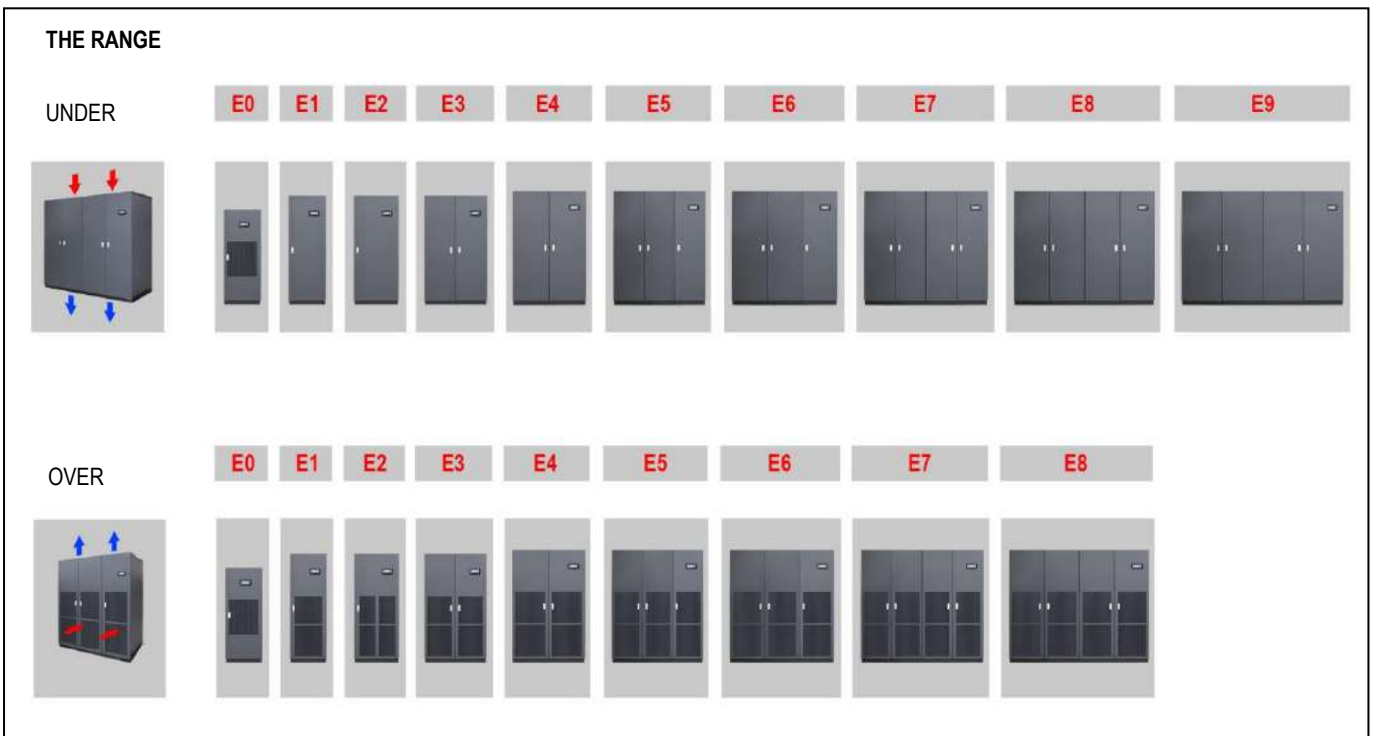

TRANSPORT AND STORAGE TEMPERATURE

During transport and if the machine is not installed at the reception, do not remove the packaging and place the machine in an enclosed, dry and protected from sunlight site at temperatures ranging between -30°C and 50°C in absence of superficial condensation.

WORKING LIMITS

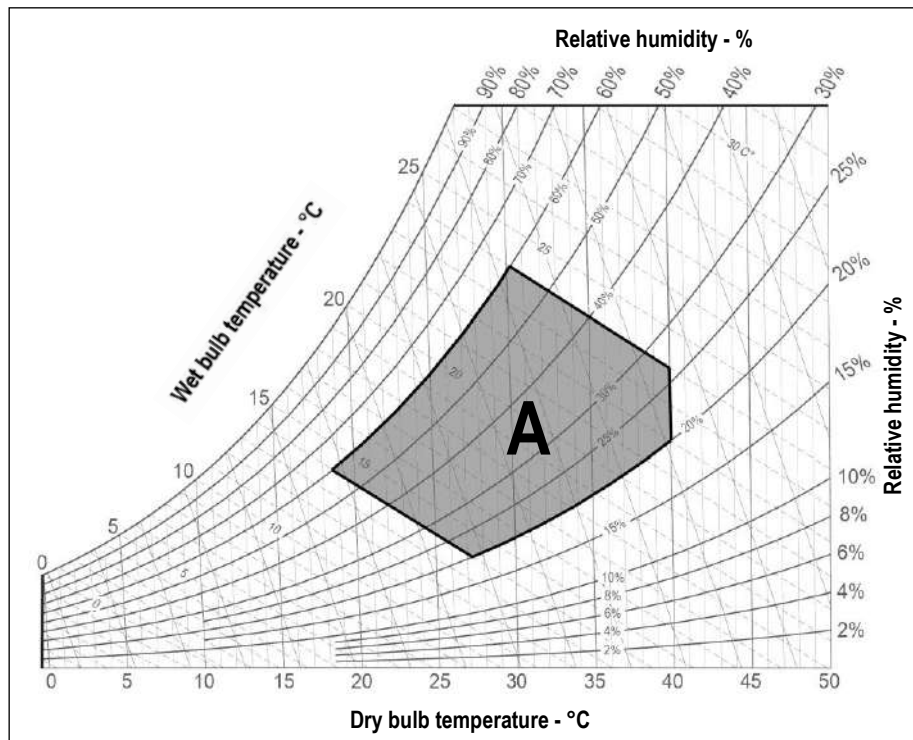

ROOM AIR CONDITIONS

Room air temperature:

- 14°C minimum temperature with wet bulb.
- 24°C maximum temperature with wet bulb.
- 18°C minimum temperature with dry bulb
- 40°C maximum temperature with dry bulb.

AREA "A". Machine operating envelope.

Room air humidity:

- 20%RH minimum relative humidity.
- 60%RH maximum relative humidity.

AMBIENT AIR TEMPERATURE

- 45°C Maximum ambient air temperature
- 20°C Minimum ambient air temperature

With "Kit for air -45°C" for low ambient temperature operation (optional)

- 45°C minimum ambient air temperature with remote condensers with AC fans

All the values are indicative. The working temperatures are influenced by a series of variables as:

- Working conditions;
- Thermal load;
- Set of the microprocessor control.

POWER SUPPLY

- ± 10% Maximum tolerance of the supply voltage (V)
- ± 2% Maximum unbalancing of the phases.

MAIN COMPONENTS



FRAMEWORK

- Base in aluminium extrusion, painted with epoxy powders. Colour RAL 9005;
- Frame in aluminium profile, painted with epoxy powders. The inner frame is provided with seals for the panels. Colour RAL 9005;
- Panels in galvanized steel sheet with protective surfaces treatment in compliance with UNI ISO 9227/ASTMB117 and ISO 7253, and painted with epoxy powders. Colour RAL 7016 hammered;
- Panels insulated with polyurethane foam and seals to ensure air tight.
- Hinged front panels with quick release removal system.
- Total front access for routine maintenance.
- Removable lateral and back side panels.
- Air flow OVER version:
 - Air intake from the front through honeycomb type grille and air delivery from the top.
- Air flow UNDER version:
 - Air intake from the front through honeycomb type grille and air delivery from the bottom.
- Machine size E0:
 - Air intake from the top and air delivery from the bottom.
- Machine size E1, E2, E3, E4, E5, E6, E7, E8, E9:
 - Air intake from the top and air delivery from the bottom.
- Compartment for electrical panel on unit front for direct access to control and regulation devices;

FILTER SECTION

- Size E0:
 - Washable air filters with COARSE 40% efficiency (according to ISO EN 16890), with cells in synthetic fibre and metallic frame.
- Size E1, E2, E3, E4, E5, E6, E7, E8, E9:
 - Washable air filters with COARSE 60% efficiency (according to ISO EN 16890), with cells in synthetic fibre and metallic frame.
- Air filters access:
 - OVER version
 - Frontal access for all machines
 - UNDER version
 - For machines size E0 - E1 - E2 - E3 frontal access
 - For machine size E4 - E5 - E6 - E7 - E8 - E9 access from upper side
- Clogged filters sensor with differential pressure switch on air side.

ON / OFF COMPRESSORS SECTION

Units size E0, E1 and E2:

- Rotary vane compressors for R410A refrigerant
- 2-pole 3-phase electric motor with direct on line starting.
- Crankcase heater.
- Rubber supports.

Units size E3, E4, E5, E6, E7, E8 and E9

- Scroll rotary compressors with spiral profile optimized for R410A refrigerant.
- 2-pole 3-phase electric motor with direct on line starting.
- Crankcase heater.
- Rubber supports.

FANS SECTION

The fan section is contained within the machine and includes:

- Centrifugal fans with backward curved blades with wing profile, single suction and without scroll housings (Plug-fans), directly coupled to external rotor electric motor.
- Impeller in composite material exempt from rust formation.
- Brushless type synchronous EC motor with integrated electronic commutated system and continuous variation of the rotation speed. The motor rotation control is obtained with the EC system (Electronic Commutation) that manage the motor according to the signal coming from the microprocessor control.
- Fans control through ModBus. In case of failure, the control stops the interested fan indicating the type of fault. The machine with more than one fan is not stopped.
- Adjustable External Static Pressure (ESP).
- Fan guard with rubber support (UNDER version)



COOLING SECTION

- Heat exchanger coil with internally corrugated copper tubes and high efficiency aluminium fins, specifically developed to provide high heat transfer and lower pressure drops.
- Frame in galvanized steel or peraluman.
- Condensate tray in peraluman with PVC flexible discharge pipe.
- Temperature sensor on air intake with control and regulation functions.
- Temperature sensor on air delivery with function of temperature display.
- Under floor water alarm through sensor to be placed on the floor.

REFRIGERANT CIRCUIT

The air conditioner is supplied with a minimum R410A refrigerant charge.

Components for each refrigerant circuit:

- Electronic expansion valve. The valve allows high performance and system efficiency thanks to a timely and accurate response to changes in temperature and pressure.
- Sight glass.
- Filter dryer on liquid line.
- Pressure transducers with indication, control and protection functions, on low and high refrigerant pressure.
- High pressure safety switch with manual reset.
- Liquid receiver.
- Pressure relief valve on liquid receiver for models 041 P1, 045 P1, 075 P2, 082 P2, 092 P2, 102 P2, 117 P4, 146 P4.
- Refrigerant circuit with copper tubing with anticondensate insulation of the suction line.
- Lubricant oil charge.
- Valves on gas delivery and liquid return for coupling to remote air-cooled condenser.
- 0÷10V proportional signal to manage the condensing control system of the remote air-cooled condenser.
- Condensing control by continuous variation of remote condenser fan rotation speed for operations with ambient temperature down to -20°C.

ELECTRICAL PANEL

In accordance with EN60204-1 norms, suitable for indoor installation, complete with:

- Main switch with door lock safety on frontal panel.
- Magnetothermic switches for each compressor.
- Magnetothermic switches for supply fans.
- Contactors for each load. The supply fans equipped with EC electric motor don't require contactors.
- Transformer for auxiliary circuit and microprocessor supply.
- Numbered wirings.
- Terminals:

OUTLETS

- Voltage free deviating contact for General Alarm 1-2.
- Voltage free contact for supply fans status.
- Voltage free contact for smoke / fire sensor (the sensors are accessory)

INLETS

- External enabling.
- Power supply 400/3+N/50.

CONTROL SYSTEM

Microprocessor control system with graphic display for control and monitor of operating and alarms status. The system includes:

- Built-in clock for alarms date and time displaying and storing;
- Built-in memory for the storing of the intervened events (up to 200 events recorded);
- Predisposition for additional connectivity board housing (MODBUS, LON, BACNET MS/TP RS485, BACNET OVER IP). The electronic cards are optional accessories.
- Main components hour-meter;
- Non-volatile "Flash" memory for data storage in case of power supply faulty;
- Menu with protection password;
- Demand Limit function (for machines with double refrigerant circuit only);
- LAN connection (max 10 units).

REMOTE AIR-COOLED CONDENSERS

The descriptions of these series can be found in Chapter REMOTE AIR-COOLED CONDENSERS.

.....	<p>Remote air-cooled condenser: Remote air-cooled condenser in PERALUMAN aluminium alloy with microchannel condensing coil:</p> <ul style="list-style-type: none"> - with AC axial fans and standard acoustic version series GX-Z A B 50; - with AC axial fans and low noise acoustic version series GX-Z A L 50; - with EC axial fans and standard acoustic version series GX-Z E B 50; - with EC axial fans and low noise acoustic version series GX-Z E L 50. <p>Remote air-cooled condenser with condensing coil with copper tubes and aluminium fins:</p> <ul style="list-style-type: none"> - with AC axial fans and standard acoustic version series BVE2 DX-A B; - with AC axial fans and low noise acoustic version series BVE2 DX-A L; - with EC axial fans and standard acoustic version series BVE2 DX-E B; - with EC axial fans and low noise acoustic version series BVE2 DX-E L. - with EC plug-fans series BVE DX-PF-E.
-------	--

OPTIONAL ACCESSORIES

The descriptions of these additional components can be found in Chapter OPTIONAL ACCESSORIES.

P121.....	<p>Front air intake + bottom panel. Unit base noise insulation with special bottom panel for OVER version (size E0 excluded). Restriction: Non-compatible with "P122 Bottom air intake + blind panels" for OVER version.</p>
P122.....	<p>Bottom air intake+blind panels. Blind frontal panel for OVER version (size E0 excluded). The accessory allows the intake air from the bottom of the machine. Restriction: Not compatible with "P121 Front air intake + bottom panel" for OVER version.</p>
601.....	<p>Solenoid valve on liquid line.</p>
A548.....	<p>Constant prevalence. Automatic system for the air pressure control in the aisle. The system controls the supply fans rotation speed to keep constant the air pressure via a differential pressure transmitter connected to the microprocessor control.</p>
P091.....	<p>Back-up module controller. The system guarantees the microprocessor power supply for a few minutes, in case of supply voltage failure. (size E0, E1 excluded).</p>
P171.....	<p>Kit for air -45°C MCH axial AC (condenser series GX-Z A B). Kit for operations with low ambient air temperature down to -45°C. For machine start up and operation with very low ambient air temperatures (between -20°C and -45°C).</p>
P172 (1).....	<p>Kit for air -45°C axial AC (condenser series BVE2 DX-A B). Kit for operations with low ambient air temperature down to -45°C. For machine start up and operation with very low ambient air temperatures (between -20°C and -45°C).</p>
P191.....	<p>Power supply for condenser. Electrical power supply for remote condenser from the indoor machine electrical board. The optional includes magneto-thermic switches for condenser fans and the control/alarm signals.</p>
383.....	<p>Numbered wirings + UK requests;</p>
4181 / 4182 / 4184 / 4185...	<p>Serial cards: 4181 – Serial card MODBUS; 4182 – Serial card LON; 4184 – Serial card BACNET MS/TP RS485; 4185 – Serial card BACNET OVER IP.</p>
A492.....	<p>Water leakage detector + additional sensor. Supplied in mounting kit.</p>
A511.....	<p>Smoke detector. Supplied in mounting kit.</p>
A521.....	<p>Fire detector. Supplied in mounting kit.</p>

P141.....	Analogue set-point compensation. - Analogue set point compensation according to an external analogue signal at Customer care (size E0 excluded).
P181.....	Network analyser (standard machine) Multifunction utility for calculating and displaying the machine electrical measurements.
P182.....	Network analyser+optional (full optional machine) Multifunction utility for calculating and displaying the machine electrical measurements.
P183.....	Kit network analyser (standard machine) Multifunction utility for calculating and displaying the machine electrical measurements. Supplied in mounting kit.
P184.....	Kit network analyser+optional (full optional machine) Multifunction utility for calculating and displaying the machine electrical measurements. Supplied in mounting kit.
A812 (2)	Free-cooling direct control. Size E0 excluded.
P131.....	Hot water coil + 2-way valve. Hot water heating system (size E0 excluded). Not compatible with "P211 Hot gas heating+4way valve".
P211 (3)	Hot gas heating+4way valve. On/off type hot gas reheating system – Only for machine with single compressor (size E0, E5, E6, E7, E8, E9 excluded). Not compatible with "P131 Hot water coil + 2-way valve".
A431.....	Electric heater. Heating with electric heaters.
A432.....	Extra power electric heater. Size E0, E1, E2 excluded.
4301 / 4303 / 4305 (4).....	Humidification: Modulating steam humidifier with immersed electrodes with electronic control. 4301 - Steam humidifier 3kg/h 4303 - Steam humidifier 8kg/h 4305 - Steam humidifier 15kg/h
P051 (5)	Dehumidification function.
P161.....	T/RH air intake sensor. Combined Temperature / Humidity sensor on air intake. The optional replace the standard temperature sensor on machine air intake.
4666	External air probe. External air temperature probe.
P071.....	Remote T/RH probe. Combined Temperature / Humidity sensor for remote installation. The optional is added to the standard temperature sensor on machine air intake.
P111 / P112 / P113 / P114	Dual power supply. Dual power supply with automatic change-over. P111 - Dual power supply. P112 - Dual power supply + optional. P113 - Dual power supply kit. Supplied in mounting kit P114 - Dual power supply kit + optional. Supplied in mounting kit
A381.....	Drain pump. Supplied in mounting kit. The system includes pump with activation float and 10 linear meters long discharge pipe.
P084.....	Air filter ePM₁₀ 50%. Washable high efficiency air filter (according to ISO EN 16890) – size E0 excluded. Not compatible with "P017 / P018 / P019 Plenum + filter ePM _{2,5} 50%, ePM ₁ 50%, ePM ₁ 85% (according to ISO EN 16890)".
A531 (6)	On-off damper. Non-return air damper with frame driven by electric servomotor installed on the machine air delivery (size E0 excluded).
P011.....	Empty plenum (size E0 excluded).
P012.....	Empty plenum CL.A1. Plenum with fire reaction in class "0" or "A1". (size E0 excluded).
P013.....	Plenum + 3 grilles on three sides with double adjustable row.
P014.....	Plenum + 3 grilles CL.A1. Plenum with grilles on three sides with double adjustable row, with fire reaction in class "0" or "A1".
P015.....	Silenced plenum. – size E0 excluded. Not compatible with "P084 Air filter ePM ₁₀ 50%".
P016.....	Silenced plenum + 1 grille. Grille with double adjustable row on front side and sound absorbers (size E0 excluded).
P017.....	Plenum + filter ePM_{2,5} 50%. Plenum with high efficiency air filter (according to ISO EN 16890) – size E0 excluded. Not compatible with "P084 Air filter ePM ₁₀ 50%".
P018.....	Plenum + filter ePM₁ 50%. Plenum with high efficiency air filter (according to ISO EN 16890) – size E0 excluded. Not compatible with "P084 Air filter ePM ₁₀ 50%".
P019.....	Plenum + filter ePM₁ 85%. Plenum with high efficiency air filter (according to ISO EN 16890) – size E0 excluded. Not compatible with "P084 Air filter ePM ₁₀ 50%".
P031 (7)	Empty intake plenum. (size E0 excluded).

P032 (7)	Empty intake plenum CL.A1. Plenum with fire reaction in class "0" or "A1". (size E0 excluded).
P034 (8)	Intake free-cooling plenum. Size E0 excluded.
P041 / P042 / P043	Support frame with height adjusting rubber holders. Supplied in mounting kit. It is not possible to match the support frame with plenum installed under the machine. P041 – Support frame h 255-350mm P042 – Support frame h 355-450mm P043 – Support frame h 400-510mm
3601	Compressor operating signal contact. Voltage free contact for compressor status signalling.
2411	Phase sequence relay. Phases sequence control relay for the machine.
1511	Soft starter. Compressor motors soft-starter system (size E0, E1, E2 excluded).
3301	Compressor rephasing. Compressors capacitor for power factor - $\cos\phi$ 0,9 (sizes E0, E1, E2 excluded).
A181	Compressor soundproof jacket. Compressor soundproof jacket for a sound level reduction of 2 dB(A).
A272	CL. 0 or A1 (EN 13501-1) insulation: Panelling with fire reaction in class "0" or "A1";
P151	Lowered display for Under – for UNDER units equipped with plenum under the unit; (size E0 excluded).
9973	Wooden cage packing. The machines are delivered on wooden pallet, covered with shrink wrap and packaged in wooden cage.
BQ39900001	Remote terminal. Graphic display for remote installation, the optional is added to the standard graphic display placed on machine frontal panel.

WARNING

The Manufacturers reserves the right to accept the matching of the optional installed on the machine.

MANDATORY COMBINATIONS OF ACCESSORIES

1. When optional accessory "P172 Kit for air -45°C axial AC" is present, it requires mandatory accessory "P191 Power supply for condenser".
2. When optional accessory "A812 Free cooling direct control" is present, it requires mandatory accessories "P161 T/rH air intake sensor" and "4666 External air probe".
3. When optional accessory "P211 Hot gas heating+4way valve" is present, it requires mandatory accessories "P051 Dehumidification function" and "P161 T/rH air intake sensor".
4. When optional accessories "4301 / 4303 / 4305 Steam humidifier" are present, they require mandatory accessory "P161 T/rH air intake sensor".
5. When optional accessory "P051 Dehumidification function" is present, it requires mandatory accessory "P161 T/rH air intake sensor".
6. When optional accessory "A531 On-off damper" is present, it requires mandatory accessory "9973 Wooden cage packing".
7. When optional accessories "P031 Empty intake plenum, for OVER version" and "P032 Empty intake plenum CL.A1, for OVER version" are present, they require mandatory accessory "P122 Bottom air intake+blind panels, for OVER version only"
8. When optional accessory "P034 Intake free-cooling plenum" is present, it requires mandatory accessories "P161 T/rH air intake sensor", "4666 External air probe", "A812 Free-cooling direct control" and "P122 Bottom air intake+blind panels, for OVER version only"

TECHNICAL DATA

VERSION (1)		U / O	U / O	U / O	U / O	U / O
MODEL		007 P1 S	009 P1 S	011 P1 S	014 P1 S	016 P1 S
SIZE		E0	E0	E1	E2	E2
COOLING CAPACITY (2)						
Total	kW	6,58	7,78	10,7	14,2	15,2
Sensible	kW	6,04	6,89	9,77	13,1	14,1
SHR (3)		0,92	0,89	0,91	0,92	0,93
Total power input (Comp. + Fans)	kW	1,61	1,98	2,57	3,23	3,69
"EC" SUPPLY FANS	n.	1	1	1	1	1
Air flow	m ³ /h	1660	1660	2800	4000	4200
Nominal external static pressure	Pa	20	20	20	20	20
Maximum external static pressure	Pa	140	140	86	343	291
Fans power input (4)	kW	0,09	0,09	0,28	0,48	0,55
ON/OFF COMPRESSORS		rotary vane	rotary vane	rotary vane	rotary vane	rotary vane
Compressors number	n.	1	1	1	1	1
Capacity steps	n.	1	1	1	1	1
Compressors power input	kW	1,52	1,89	2,28	2,75	3,14
AIR FILTERS	n.	1	1	1	1	1
Filter area	m ²	0,28	0,28	0,61	0,78	0,78
Efficiency (ISO EN 16890)	COARSE	40%	40%	60%	60%	60%
REFRIGERANT CIRCUITS	n.	1	1	1	1	1
POWER SUPPLY	V/Ph/Hz	400/3+N/50	400/3+N/50	400/3+N/50	400/3+N/50	400/3+N/50
ENERGY EFFICIENCY INDEX (2) (5)						
EER Energy Efficiency Ratio	kW/kW	4,09	3,93	4,16	4,40	4,12
DIMENSIONS						
Length	mm	655	655	650	785	785
Width	mm	445	445	675	675	675
Height	mm	1680	1680	1925	1925	1925
NET WEIGHT OVER	kg	160	160	228	260	265
NET WEIGHT UNDER	kg	160	160	238	270	275
REFRIGERANT CONNECTIONS						
Gas delivery	ODS Ø	12	12	12	16	16
Liquid return	ODS Ø	12	12	12	12	12
HYDRAULIC CONNECTIONS						
CONDENSATE DISCHARGE						
Rubber pipe – internal diameter	Ø mm	19	19	19	19	19

THE COOLING CAPACITY DOES NOT CONSIDER THE SUPPLY FAN MOTOR THERMAL LOAD

1. U = Under, downflow / O = Over, upflow
2. Gross value. Characteristics referred to entering air at 26°C-40%RH; condensing temperature 45°C. ESP=20Pa.
3. SHR = Sensible cooling capacity / Total cooling capacity.
4. Corresponding to the nominal external static pressure
5. The Energy Efficiency Index does not consider the remote air-cooled condenser.

The units highlighted in this publication contain <HFC R410A [GWP₁₀₀ 2088]> fluorinated greenhouse gas

TECHNICAL DATA

VERSION (1)		U / O	U / O	U / O	U / O	U / O
MODEL		020 P1 S	022 P1 S	026 P1 S	032 P1 S	037 P1 S
SIZE		E3	E3	E3	E4	E4
COOLING CAPACITY (2)						
Total	kW	20,2	22,4	26,8	33,2	38,5
Sensible	kW	19,5	21,3	24,8	31,5	36,4
SHR (3)		0,97	0,95	0,93	0,95	0,95
Total power input (Comp. + Fans)	kW	4,50	5,46	6,71	7,58	9,22
"EC" SUPPLY FANS						
"EC" SUPPLY FANS	n.	1	1	1	1	1
Air flow	m³/h	5700	6100	6400	8700	10000
Nominal external static pressure	Pa	20	20	20	20	20
Maximum external static pressure	Pa	1000	1000	966	860	578
Fans power input (4)	kW	0,83	1,01	1,16	1,39	2,06
ON/OFF COMPRESSORS						
ON/OFF COMPRESSORS		scroll	scroll	scroll	scroll	scroll
Compressors number	n.	1	1	1	1	1
Capacity steps	n.	1	1	1	1	1
Compressors power input	kW	3,67	4,45	5,55	6,19	7,16
AIR FILTERS						
AIR FILTERS	n.	2	2	2	2	2
Filter area	m²	1,24	1,24	1,24	2,07	2,07
Efficiency (ISO EN 16890)	COARSE	60%	60%	60%	60%	60%
REFRIGERANT CIRCUITS						
REFRIGERANT CIRCUITS	n.	1	1	1	1	1
POWER SUPPLY						
POWER SUPPLY	V/Ph/Hz	400/3+N/50	400/3+N/50	400/3+N/50	400/3+N/50	400/3+N/50
ENERGY EFFICIENCY INDEX (2) (5)						
EER Energy Efficiency Ratio	kW/kW	4,48	4,10	3,99	4,38	4,18
DIMENSIONS						
Length	mm	1085	1085	1085	1305	1305
Width	mm	775	775	775	930	930
Height	mm	1925	1925	1925	1980	1980
NET WEIGHT OVER						
NET WEIGHT OVER	kg	300	305	305	410	415
NET WEIGHT UNDER						
NET WEIGHT UNDER	kg	320	325	325	420	425
REFRIGERANT CONNECTIONS						
Gas delivery	ODS Ø	16	16	22	22	22
Liquid return	ODS Ø	16	16	16	16	16
HYDRAULIC CONNECTIONS						
CONDENSATE DISCHARGE						
Rubber pipe – internal diameter	Ø mm	19	19	19	19	19

THE COOLING CAPACITY DOES NOT CONSIDER THE SUPPLY FAN MOTOR THERMAL LOAD

1. U = Under, downflow / O = Over, upflow
2. Gross value. Characteristics referred to entering air at 26°C-40%RH; condensing temperature 45°C. ESP=20Pa.
3. SHR = Sensible cooling capacity / Total cooling capacity.
4. Corresponding to the nominal external static pressure
5. The Energy Efficiency Index does not consider the remote air-cooled condenser.

The units highlighted in this publication contain <HFC R410A [GWP₁₀₀ 2088]> fluorinated greenhouse gas

TECHNICAL DATA

VERSION (1)		U / O	U / O	U / O	U / O	U / O
MODEL		041 P1 S	045 P1 S	039 P2 D	048 P2 D	055 P2 D
SIZE		E4	E4	E5	E5	E6
COOLING CAPACITY (2)						
Total	kW	42,6	46,4	38,9	49,8	56,3
Sensible	kW	40,1	42,6	36,9	46,4	53,4
SHR (3)		0,94	0,92	0,95	0,93	0,95
Total power input (Comp. + Fans)	kW	10,1	11,2	9,14	12,5	13,5
"EC" SUPPLY FANS						
	n.	1	1	1	1	2
Air flow	m³/h	10800	10800	10000	12000	15000
Nominal external static pressure	Pa	20	20	20	20	20
Maximum external static pressure	Pa	535	535	666	420	970
Fans power input (4)	kW	2,04	2,04	1,79	2,27	2,34
ON/OFF COMPRESSORS						
		scroll	scroll	scroll	scroll	scroll
Compressors number	n.	1	1	2	2	2
Capacity steps	n.	1	1	2	2	2
Compressors power input	kW	8,10	9,14	7,35	10,2	11,2
AIR FILTERS						
	n.	2	2	3	3	3
Filter area	m²	2,07	2,07	2,59	2,59	3,16
Efficiency (ISO EN 16890)	COARSE	60%	60%	60%	60%	60%
REFRIGERANT CIRCUITS						
	n.	1	1	2	2	2
POWER SUPPLY						
	V/Ph/Hz	400/3+N/50	400/3+N/50	400/3+N/50	400/3+N/50	400/3+N/50
ENERGY EFFICIENCY INDEX (2) (5)						
EER Energy Efficiency Ratio	kW/kW	4,22	4,14	4,26	3,98	4,17
DIMENSIONS						
Length	mm	1305	1305	1630	1630	1875
Width	mm	930	930	930	930	930
Height	mm	1980	1980	1980	1980	1980
NET WEIGHT OVER						
	kg	427	435	520	530	610
NET WEIGHT UNDER						
	kg	437	445	530	540	620
REFRIGERANT CONNECTIONS						
Gas delivery	ODS Ø	22	22	2x16	2x16	2x22
Liquid return	ODS Ø	22	22	2x16	2x16	2x16
HYDRAULIC CONNECTIONS						
CONDENSATE DISCHARGE						
Rubber pipe – internal diameter	Ø mm	19	19	19	19	19

THE COOLING CAPACITY DOES NOT CONSIDER THE SUPPLY FAN MOTOR THERMAL LOAD

1. U = Under, downflow / O = Over, upflow
2. Gross value. Characteristics referred to entering air at 26°C-40%RH; condensing temperature 45°C. ESP=20Pa.
3. SHR = Sensible cooling capacity / Total cooling capacity.
4. Corresponding to the nominal external static pressure
5. The Energy Efficiency Index does not consider the remote air-cooled condenser.

The units highlighted in this publication contain <HFC R410A [GWP₁₀₀ 2088]> fluorinated greenhouse gas

TECHNICAL DATA

VERSION (1)		U / O	U / O	U / O	U / O	U / O
MODEL		062 P2 D	075 P2 D	082 P2 D	092 P2 D	102 P2 D
SIZE		E6	E7	E7	E8	E8
COOLING CAPACITY (2)						
Total	kW	63,5	77,1	84,4	94,5	106
Sensible	kW	59,3	72,9	77,9	86,6	94,2
SHR (3)		0,93	0,95	0,92	0,92	0,89
Total power input (Comp. + Fans)	kW	15,0	17,8	19,7	22,0	25,7
"EC" SUPPLY FANS						
	n.	2	2	2	2	2
Air flow	m ³ /h	15600	20000	20000	22000	22000
Nominal external static pressure	Pa	20	20	20	20	20
Maximum external static pressure	Pa	913	649	649	576	576
Fans power input (4)	kW	2,62	3,51	3,51	3,72	3,72
ON/OFF COMPRESSORS						
		scroll	scroll	scroll	scroll	scroll
Compressors number	n.	2	2	2	2	2
Capacity steps	n.	2	2	2	2	2
Compressors power input	kW	12,4	14,3	16,2	18,3	22,0
AIR FILTERS						
	n.	3	4	4	5	5
Filter area	m ²	3,16	3,82	3,82	4,46	4,46
Efficiency (ISO EN 16890)	COARSE	60%	60%	60%	60%	60%
REFRIGERANT CIRCUITS						
	n.	2	2	2	2	2
POWER SUPPLY						
	V/Ph/Hz	400/3+N/50	400/3+N/50	400/3+N/50	400/3+N/50	400/3+N/50
ENERGY EFFICIENCY INDEX (2) (5)						
EER Energy Efficiency Ratio	kW/kW	4,23	4,33	4,28	4,30	4,12
DIMENSIONS						
Length	mm	1875	2175	2175	2499	2499
Width	mm	930	930	930	930	930
Height	mm	1980	1980	1980	1980	1980
NET WEIGHT OVER						
	kg	630	688	695	785	785
NET WEIGHT UNDER						
	kg	640	745	750	845	845
REFRIGERANT CONNECTIONS						
Gas delivery	ODS Ø	2x22	2x22	2x22	2x22	2x22
Liquid return	ODS Ø	2x16	2x22	2x22	2x22	2x22
HYDRAULIC CONNECTIONS						
CONDENSATE DISCHARGE						
Rubber pipe – internal diameter	Ø mm	19	19	19	19	19

THE COOLING CAPACITY DOES NOT CONSIDER THE SUPPLY FAN MOTOR THERMAL LOAD

1. U = Under, downflow / O = Over, upflow
2. Gross value. Characteristics referred to entering air at 26°C-40%RH; condensing temperature 45°C. ESP=20Pa.
3. SHR = Sensible cooling capacity / Total cooling capacity.
4. Corresponding to the nominal external static pressure
5. The Energy Efficiency Index does not consider the remote air-cooled condenser.

The units highlighted in this publication contain <HFC R410A [GWP₁₀₀ 2088]> fluorinated greenhouse gas

TECHNICAL DATA

VERSION (1)		U	U
MODEL		117 P4 D	146 P4 D
SIZE		E9	E9
COOLING CAPACITY (2)			
Total	kW	121	149
Sensible	kW	119	139
SHR (3)		0,98	0,93
Total power input (Comp. + Fans)	kW	30,4	38,0
"EC" SUPPLY FANS			
	n.	3	3
Air flow	m³/h	32000	32000
Nominal external static pressure	Pa	20	20
Maximum external static pressure	Pa	583	583
Fans power input (4)	kW	5,66	5,66
ON/OFF COMPRESSORS			
		scroll	scroll
Compressors number	n.	4	4
Capacity steps	n.	4	4
Compressors power input	kW	24,8	32,4
AIR FILTERS			
	n.	5	5
Filter area	m²	5,24	5,24
Efficiency (ISO EN 16890)	COARSE	60%	60%
REFRIGERANT CIRCUITS			
	n.	2	2
POWER SUPPLY			
	V/Ph/Hz	400/3+N/50	400/3+N/50
ENERGY EFFICIENCY INDEX (2) (5)			
EER Energy Efficiency Ratio	kW/kW	3,98	3,92
DIMENSIONS			
Length	mm	2899	2899
Width	mm	930	930
Height	mm	1980	1980
NET WEIGHT OVER			
	kg	--	--
NET WEIGHT UNDER			
	kg	1020	1080
REFRIGERANT CONNECTIONS			
Gas delivery	ODS Ø	2x28	2x28
Liquid return	ODS Ø	2x22	2x22
HYDRAULIC CONNECTIONS			
CONDENSATE DISCHARGE			
Rubber pipe – internal diameter	Ø mm	19	19

THE COOLING CAPACITY DOES NOT CONSIDER THE SUPPLY FAN MOTOR THERMAL LOAD

1. U = Under, downflow / O = Over, upflow
2. Gross value. Characteristics referred to entering air at 26°C-40%RH; condensing temperature 45°C. ESP=20Pa.
3. SHR = Sensible cooling capacity / Total cooling capacity.
4. Corresponding to the nominal external static pressure
5. The Energy Efficiency Index does not consider the remote air-cooled condenser.

The units highlighted in this publication contain <HFC R410A [GWP₁₀₀ 2088]> fluorinated greenhouse gas

REFRIGERANT CHARGE

The air conditioner is supplied with a minimum R410A refrigerant charge. **Refrigerant must be charged.** The following table shows the refrigerant charge that must be introduced for the air conditioner only. Remote condenser, connections pipes and optional are excluded.

VERSION (1)		U / O	U / O	U / O	U / O	U / O
MODEL		007 P1 S	009 P1 S	011 P1 S	014 P1 S	016 P1 S
SIZE		E0	E0	E1	E2	E2
REFRIGERANT		R410A	R410A	R410A	R410A	R410A
Refrigerant circuits x Refrigerant charge (1)	n x kg	1 x 2,3	1 x 2,3	1 x 3,2	1 x 3,4	1 x 3,4
HFC R410A - F Gas - CO ₂ equivalent	t	4,80	4,80	6,68	7,10	7,10

VERSION (1)		U / O	U / O	U / O	U / O	U / O
MODEL		020 P1 S	022 P1 S	026 P1 S	032 P1 S	037 P1 S
SIZE		E3	E3	E3	E4	E4
REFRIGERANT		R410A	R410A	R410A	R410A	R410A
Refrigerant circuits x Refrigerant charge (1)	n x kg	1 x 4,0	1 x 4,0	1 x 4,0	1 x 5,7	1 x 5,7
HFC R410A - F Gas - CO ₂ equivalent	t	8,35	8,35	8,35	11,90	11,90

VERSION (1)		U / O	U / O	U / O	U / O	U / O
MODEL		041 P1 S	045 P1 S	039 P2 D	048 P2 D	055 P2 D
SIZE		E4	E4	E5	E5	E6
REFRIGERANT		R410A	R410A	R410A	R410A	R410A
Refrigerant circuits x Refrigerant charge (1)	n x kg	1 x 8,6	1 x 8,6	2 x 4,5	2 x 4,5	2 x 4,9
HFC R410A - F Gas - CO ₂ equivalent	t	17,96	17,96	18,79	18,79	20,46

VERSION (1)		U / O	U / O	U / O	U / O	U / O
MODEL		062 P2 D	075 P2 D	082 P2 D	092 P2 D	102 P2 D
SIZE		E6	E7	E7	E8	E8
REFRIGERANT		R410A	R410A	R410A	R410A	R410A
Refrigerant circuits x Refrigerant charge (1)	n x kg	2 x 4,9	2 x 8,1	2 x 8,1	2 x 8,7	2 x 8,7
HFC R410A - F Gas - CO ₂ equivalent	t	20,46	33,83	33,83	36,33	36,33

VERSION (1)		U	U
MODEL		117 P4 D	146 P4 D
SIZE		E9	E9
REFRIGERANT		R410A	R410A
Refrigerant circuits x Refrigerant charge (1)	n x kg	2 x 10,8	2 x 10,8
HFC R410A - F Gas - CO ₂ equivalent	t	45,1	45,1

1. U = Under, downflow / O = Over, upflow
2. Refrigerant charge required for the air conditioner only operation. Remote condenser, connections pipes and optional are excluded. For air conditioners with double refrigerant circuit is indicated the number of circuits x the charge of a single circuit.

PRESSURE RELIEF VALVE

The pressure relief valve of the refrigerant circuit is installed in the machines when required by Directive 2014/68/EU. The valve is installed on liquid receiver of each refrigerant circuit of the machine with the purpose to protect the circuit from overpressure.

It is up to the installer to check whether the system complies with the 2014/68 / EU standard regarding the installation of the pressure relief valve. By plant we mean the complete system that includes the internal machine, the remote condenser and the connecting pipes

The installer must calculate the amount of refrigerant contained in the system and, if the refrigerant charge is higher than 10 kg, he must install the pressure relief valve.

	Factory installed components	At Installer care
	Pressure relief valve on liquid receiver	Possible pressure relief valve
Model	[bar]	[bar]
007 P1 S	---	41,5
009 P1 S	---	41,5
011 P1 S	---	41,5
014 P1 S	---	41,5
016 P1 S	---	41,5
020 P1 S	---	45,0
022 P1 S	---	45,0
026 P1 S	---	45,0
032 P1 S	---	45,0
037 P1 S	---	45,0
041 P1 S	45,0	---
045 P1 S	45,0	---
039 P2 D	---	45,0
048 P2 D	---	45,0
055 P2 D	---	45,0
062 P2 D	---	45,0
075 P2 D	45,0	---
082 P2 D	45,0	---
092 P2 D	45,0	---
102 P2 D	45,0	---
117 P4 D	45,0	---
146 P4 D	45,0	---

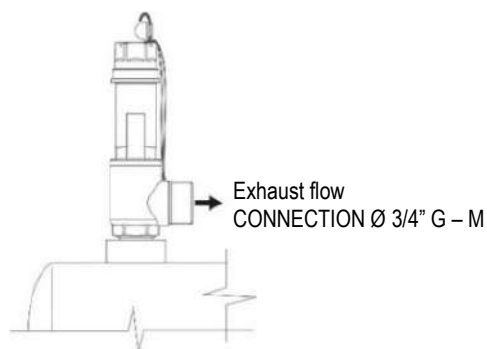

REFRIGERANT CIRCUIT

Below refrigerant diagrams for version with single or double refrigerant circuit. The diagrams refer to the standard configuration, without optional.

UNDER - SINGLE REFRIGERANT CIRCUIT

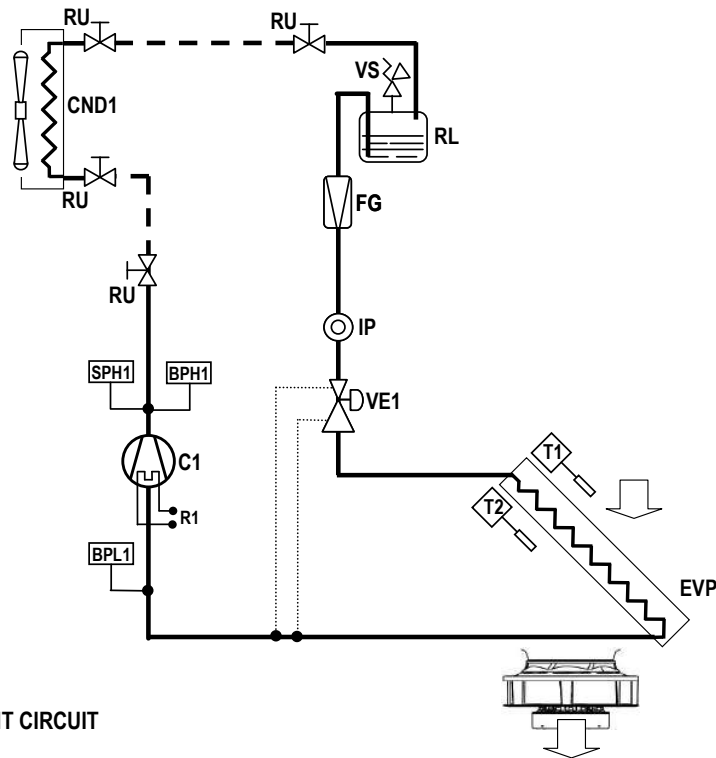

VS = Pressure relief valve
Only models 041 P1, 045 P1

OVER - SINGLE REFRIGERANT CIRCUIT

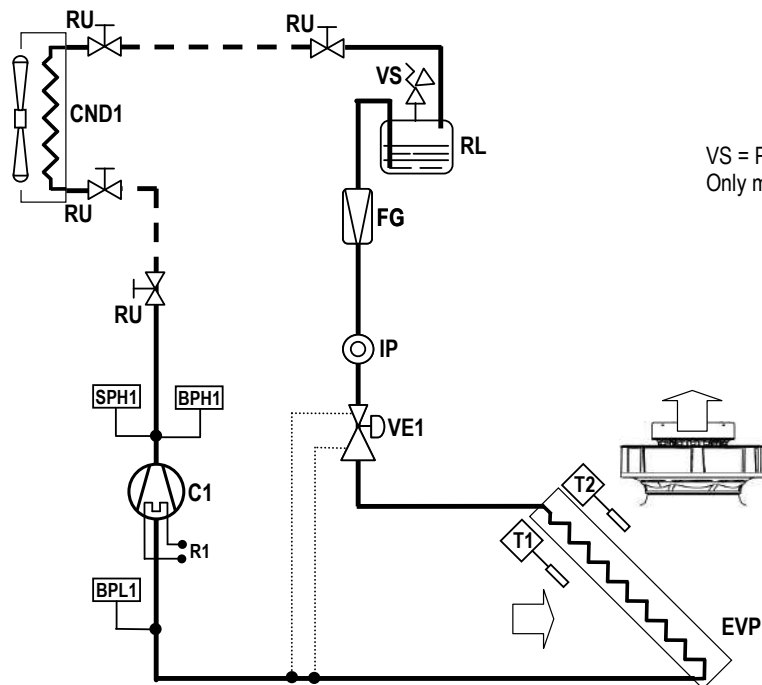

VS = Pressure relief valve
Only models 041 P1, 045 P1

LEGENDA

- C1 Compressor
- R1 Crankcase heater
- CND Condenser.
- EVP Evaporator.
- BPH High pressure transducer.

- BPL Low pressure transducer.
- SPH High pressure switch
- VS Pressure relief valve.
- FG Refrigerant filter.

- IP Sight glass.
- VE Expansion valve.
- T Temperature probes.
- RU Valves
- RL Liquid receiver

UNDER - DOUBLE REFRIGERANT CIRCUIT

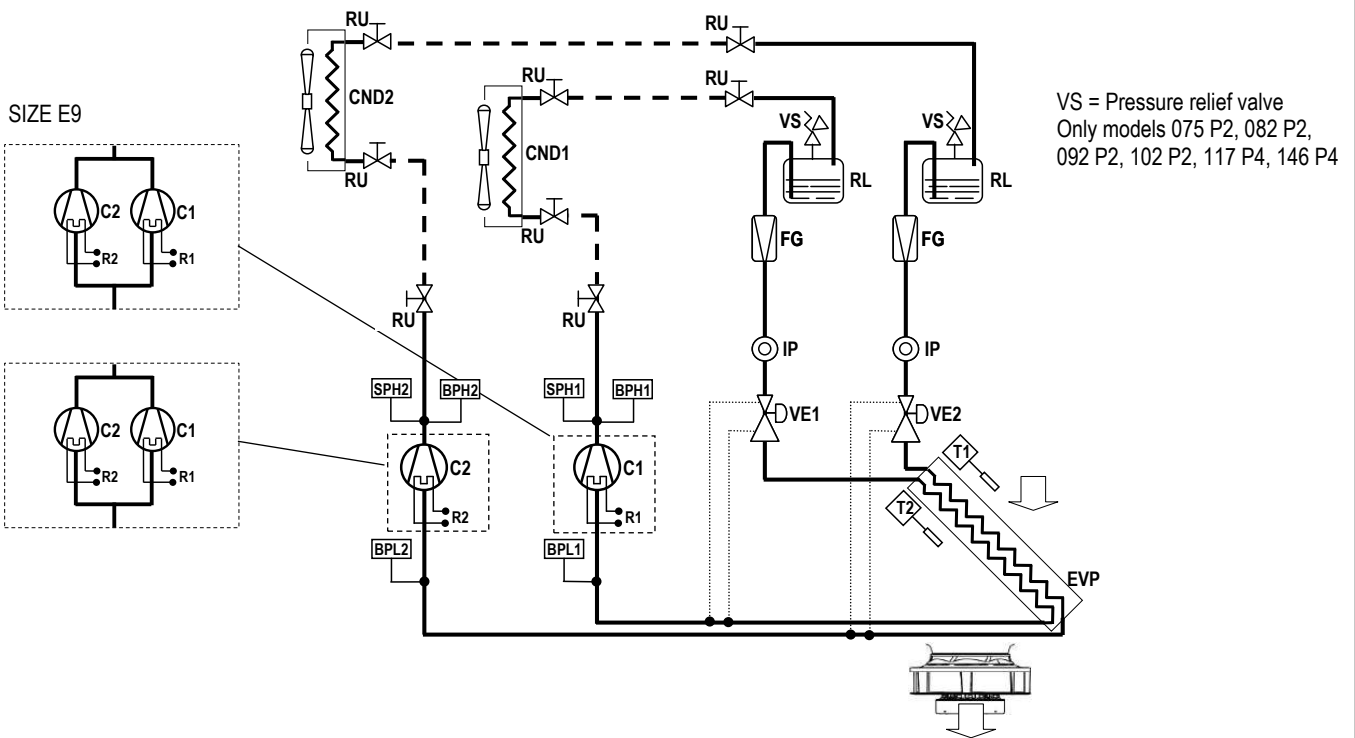

OVER - DOUBLE REFRIGERANT CIRCUIT

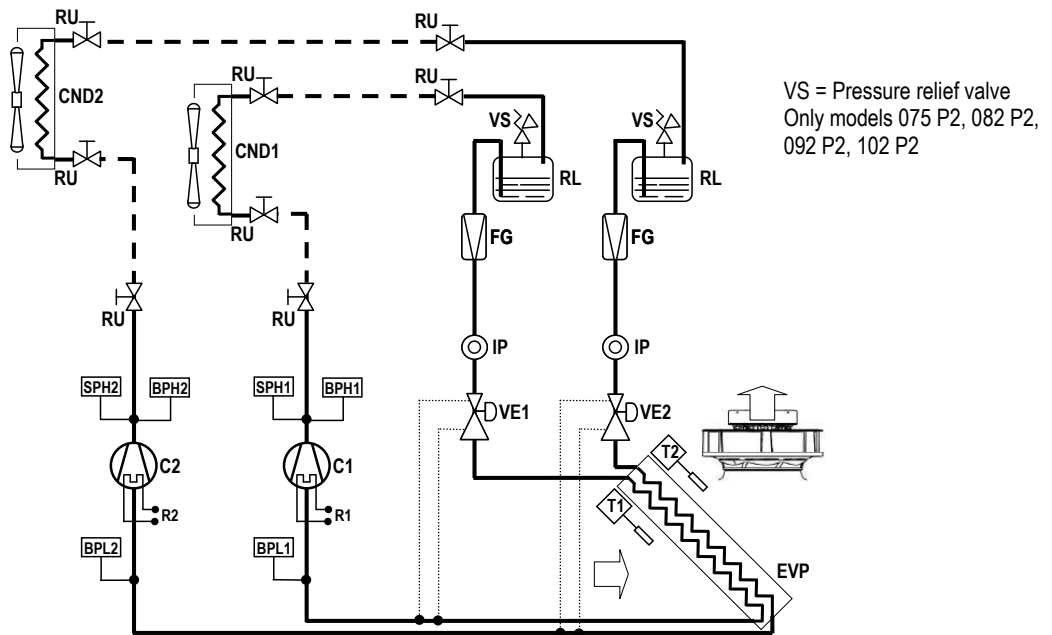

LEGENDA

- C1...2 Compressor 1, 2
- R1...2 Crankcase heater 1, 2
- CND Condenser.
- EVP Evaporator.
- BPH High pressure transducer.

- BPL Low pressure transducer.
- SPH High pressure switch
- VS Pressure relief valve.
- FG Refrigerant filter.

- IP Sight glass.
- VE Expansion valve.
- T Temperature probes.
- RU Valves
- RL Liquid receiver

RECOMMENDED REFRIGERANT LINES

Diameter of the recommended refrigerant lines for connection to MEHITS S.p.A. air conditioners and referred to "EQUIVALENT LENGHT". Please always refer to the "INSTALLATION DIAGRAM" to properly select all necessary components. Verify the need to use pressure limiting devices (safety valves) where not already provided for by Directive 2014/68 / EU.

Nominal diameter: Refrigerant connection of the indoor unit. In some cases, the diameter of the refrigerant lines may not correspond with the nominal diameter. This is completely normal. It is enough to provide a reduction fitting to adjust the diameter.

"SI" INTERNATIONAL SYSTEM PIPES DIAMETERS

SI system	Diameter	mm	6	8	10	12	16	18	22	28	35
	Thickness	mm	1	1	1	1	1	1	1	1,5	1,5

ON/OFF COMPRESSORS

Model	Line	Nominal diameter Ø [mm]	EQUIVALENT LENGHT FOR ON/OFF COMPRESSORS R410A									
			5[m]	10[m]	15[m]	20[m]	25[m]	30[m]	35[m]	40[m]	45[m]	50[m]
007 P1 S	Gas	12	12mm									
	Liquid	12	12mm									
009 P1 S	Gas	12	12mm									
	Liquid	12	12mm									
011 P1 S	Gas	12	12mm					16mm				
	Liquid	12	12mm									
014 P1 S	Gas	16	16mm									
	Liquid	12	12mm					16mm				
016 P1 S	Gas	16	16mm									
	Liquid	12	12mm					16mm				
020 P1 S	Gas	16	16mm					18mm				
	Liquid	16	16mm									
022 P1 S	Gas	16	16mm					18mm				
	Liquid	16	16mm									
026 P1 S	Gas	22	18mm					22mm				
	Liquid	16	16mm					18mm				
032 P1 S	Gas	22	18mm					22mm				
	Liquid	16	16mm					18mm				
037 P1 S	Gas	22	18mm					22mm				
	Liquid	16	16mm					18mm				
041 P1 S	Gas	22	22mm									
	Liquid	22	22mm									
045 P1 S	Gas	22	22mm									
	Liquid	22	22mm									
039 P2 D	Gas	16	16mm					18mm				
	Liquid	16	16mm									
048 P2 D	Gas	16	16mm					18mm				
	Liquid	16	16mm					18mm				
055 P2 D	Gas	22	18mm					22mm				
	Liquid	16	16mm					18mm				
062 P2 D	Gas	22	18mm					22mm				
	Liquid	16	16mm					18mm				
075 P2 D	Gas	22	22mm									
	Liquid	22	22mm									
082 P2 D	Gas	22	22mm									
	Liquid	22	22mm									
092 P2 D	Gas	22	22mm									
	Liquid	22	22mm									
102 P2 D	Gas	22	22mm					28mm				
	Liquid	22	22mm									
117 P4 D	Gas	28	22mm					28mm				
	Liquid	22	22mm									
146 P4 D	Gas	28	22mm					28mm				
	Liquid	22	22mm					28mm				

For equivalent lengths over 50m, please contact the Manufacturer's Sales Office.

“IMPERIAL” SYSTEM PIPES DIAMETERS

IMPERIAL system	Diameter	inch	1/4"	3/8"	1/2"	5/8"	3/4"	7/8"	1"	1 1/8"	1 3/8"
		mm	mm	6,35	9,52	12,7	15,87	19,05	22,22	25,4	28,57
	Thickness	mm	1	1	1	1	1	1	1	1,25	1,25

ON/OFF COMPRESSORS

Model	Line	Nominal diameter Ø [mm]	EQUIVALENT LENGHT FOR ON/OFF COMPRESSORS R410A									
			15[ft] 5[m]	35[ft] 10[m]	50[ft] 15[m]	65[ft] 20[m]	80[ft] 25[m]	100[ft] 30[m]	115[ft] 35[m]	130[ft] 40[m]	150[ft] 45[m]	165[ft] 50[m]
007 P1 S	Gas	12	1/2"									
	Liquid	12	1/2"									
009 P1 S	Gas	12	1/2"									
	Liquid	12	1/2"									
011 P1 S	Gas	12	1/2"				5/8"					
	Liquid	12	1/2"									
014 P1 S	Gas	16	5/8"									
	Liquid	12	1/2"			5/8"						
016 P1 S	Gas	16	5/8"									
	Liquid	12	1/2"			5/8"						
020 P1 S	Gas	16	5/8"					3/4"				
	Liquid	16	5/8"									
022 P1 S	Gas	16	5/8"					3/4"				
	Liquid	16	5/8"									
026 P1 S	Gas	22	3/4"					7/8"				
	Liquid	16	5/8"			3/4"						
032 P1 S	Gas	22	3/4"			7/8"						
	Liquid	16	5/8"			3/4"						
037 P1 S	Gas	22	3/4"			7/8"						
	Liquid	16	5/8"			3/4"						
041 P1 S	Gas	22	7/8"									
	Liquid	22	7/8"									
045 P1 S	Gas	22	7/8"									
	Liquid	22	7/8"									
039 P2 D	Gas	16	5/8"					3/4"				
	Liquid	16	5/8"									
048 P2 D	Gas	16	5/8"					3/4"				
	Liquid	16	5/8"					3/4"				
055 P2 D	Gas	22	3/4"					7/8"				
	Liquid	16	5/8"			3/4"						
062 P2 D	Gas	22	3/4"					7/8"				
	Liquid	16	5/8"			3/4"						
075 P2 D	Gas	22	7/8"									
	Liquid	22	7/8"									
082 P2 D	Gas	22	7/8"									
	Liquid	22	7/8"									
092 P2 D	Gas	22	7/8"									
	Liquid	22	7/8"									
102 P2 D	Gas	22	7/8"							1"		
	Liquid	22	7/8"									
117 P4 D	Gas	28	7/8"					1 1/8"				
	Liquid	22	7/8"									
146 P4 D	Gas	28	7/8"					1 1/8"				
	Liquid	22	7/8"			1 1/8"						

For equivalent lengths over 165ft / 50m, please contact the Manufacturer's Sales Office.

INSTALLATION DIAGRAM

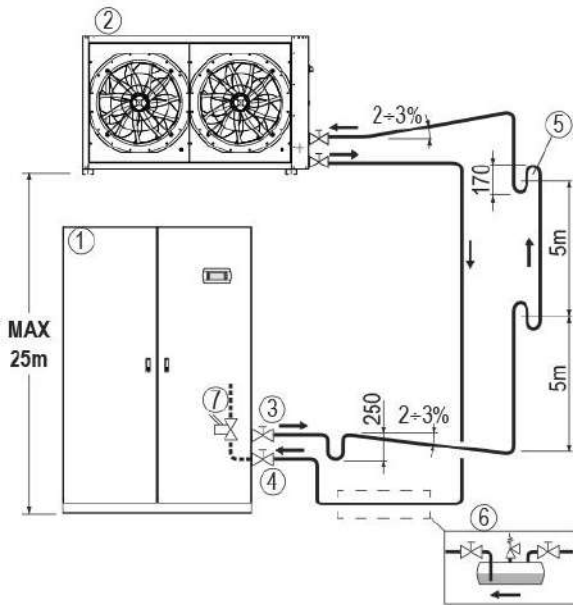

CARRY OUT PIPING WITH SLOPES INDICATED TO FAVOR THE RETURN OF THE LUBRICANT OIL TO THE COMPRESSOR

APPLY THE DIAGRAM TO ANY REFRIGERANT CIRCUIT OF THE MACHINE.

Difference in height between the machine and the remote condenser: Value expressed in equivalent length

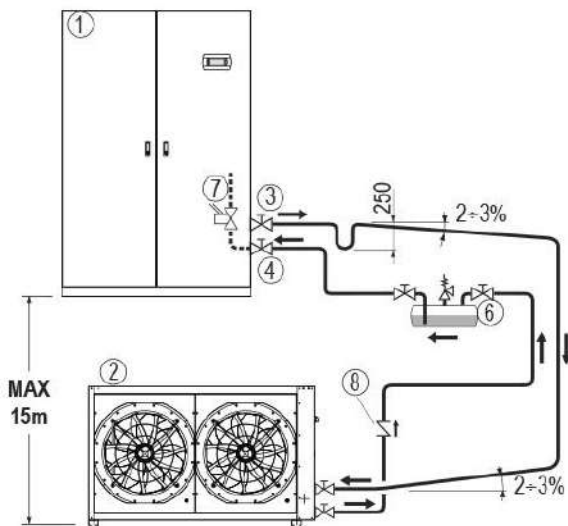

LEGENDA

1. Air conditioner.
2. Remote air-cooled condenser.
3. Gas discharge line.
4. Liquid return line.
5. Trap. Foresee a trap every 5m of the rising pipe.
6. Additional liquid receiver, external to the machine – By the installer.
It is suggested for:
 - Plants with refrigerant lines with an equivalent length of more than 25 meters
 - Plants with refrigerant lines of any length and operating at outdoor temperatures below 0°C.
7. "601 Solenoid valve on liquid line". Optional accessory of the machine, suggested for plants with refrigerant pipe longer than 10m.
8. Check valve – By the Installer. The valve must be installed on the liquid line close to the condenser. The valve prevents the return of liquid in the condenser, particularly in the case of plant shutdown during the winter season.

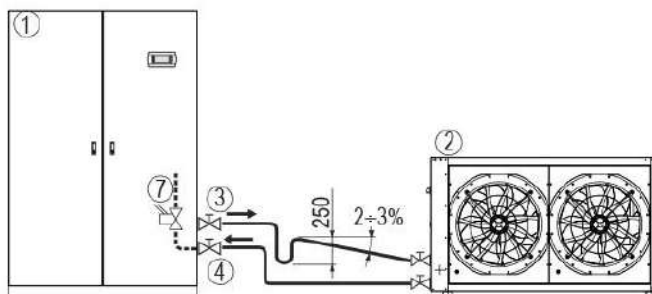

WARNING

It is necessary to provide the refrigerant charge for the connection pipes and for the remote air-cooled condenser. Charge refrigerant in the suitable quantity and lubricant oil in 10% ratio of charged refrigerant. Lubricant oil must be the same type as the charged one as shown on the compressor plate.

ACOUSTIC DATA

Acoustic data of the standard machine at full load working conditions.

WARNING:

In a closed room the noise produced by a sound source reaches the listener in two different ways:

- Directly
- Reflected from the surrounding walls, floor, ceiling, from furniture.

With the same sound source, the noise produced in a closed room is greater than that produced outdoors. In fact, the sound pressure level generated by the source, must be added to the one reflected from the room. Also, the shape of the room affects the sound.

MODEL		007 P1 S	009 P1 S	011 P1 S	014 P1 S	016 P1 S	020 P1 S
SIZE		E0	E0	E1	E2	E2	E3
SOUND LEVEL ISO 3744 (1)							
On air delivery, Under	dB(A)	61,2	61,2	64,7	70,8	71,9	70,3
On air intake, Under	dB(A)	49,5	49,5	55,9	56,9	58,1	57,0
On front side, Under	dB(A)	43	43	47	48	49	48
On air delivery, Over	dB(A)	61,2	61,2	64,7	70,8	71,9	70,3
On air intake, Over (2)	dB(A)	52	52	52	54	55	55
On front side, Over (3)	dB(A)	42,1	42,1	41,8	47,1	48,1	46,7

MODEL		022 P1 S	026 P1 S	032 P1 S	037 P1 S	041 P1 S	045 P1 S
SIZE		E3	E3	E4	E4	E4	E4
SOUND LEVEL ISO 3744 (1)							
On air delivery, Under	dB(A)	71,8	72,8	78,1	81,1	78,9	78,9
On air intake, Under	dB(A)	58,9	59,2	64,2	67,1	66,4	66,4
On front side, Under	dB(A)	50	50	55	58	57	57
On air delivery, Over	dB(A)	71,8	72,8	78,1	81,1	78,9	78,9
On air intake, Over (2)	dB(A)	59	57	61	63	62	62
On front side, Over (3)	dB(A)	48,7	49,0	54,3	57,3	56,8	56,8

MODEL		039 P2 D	048 P2 D	055 P2 D	062 P2 D	075 P2 D	082 P2 D
SIZE		E5	E5	E6	E6	E7	E7
SOUND LEVEL ISO 3744 (1)							
On air delivery, Under	dB(A)	81,3	81,5	77,9	78,7	80,1	80,1
On air intake, Under	dB(A)	67,3	69,0	64,1	65,0	67,8	67,8
On front side, Under	dB(A)	58	60	55	56	58	58
On air delivery, Over	dB(A)	81,3	81,5	77,9	78,7	80,1	80,1
On air intake, Over (2)	dB(A)	63	64	61	62	64	64
On front side, Over (3)	dB(A)	57,6	59,4	54,1	55,0	58,1	58,1

MODEL		092 P2 D	102 P2 D	117 P4 D	146 P4 D
SIZE		E8	E8	E9	E9
SOUND LEVEL ISO 3744 (1)					
On air delivery, Under	dB(A)	82,5	82,5	83,4	83,4
On air intake, Under	dB(A)	70,1	70,1	70,9	70,9
On front side, Under	dB(A)	61	61	62	62
On air delivery, Over	dB(A)	82,5	82,5	--	--
On air intake, Over (2)	dB(A)	66	67	--	--
On front side, Over (3)	dB(A)	60,4	60,4	--	--

1. Noise pressure level at 1 meter in free field – ISO 3744
2. Air intake from the front
3. Air intake from the bottom

ELECTRICAL DATA

Electrical data of the system at full load working conditions.

VERSION (1)		U / O	U / O	U / O	U / O	U / O
MODEL		007 P1 S	009 P1 S	011 P1 S	014 P1 S	016 P1 S
SIZE		E0	E0	E1	E2	E2
Power supply	V/ph/Hz	400/3+N/50	400/3+N/50	400/3+N/50	400/3+N/50	400/3+N/50
Maximum current input (FLA)	A	5,94	6,82	9,52	10,0	11,5

VERSION (1)		U / O	U / O	U / O	U / O	U / O
MODEL		020 P1 S	022 P1 S	026 P1 S	032 P1 S	037 P1 S
SIZE		E3	E3	E3	E4	E4
Power supply	V/ph/Hz	400/3+N/50	400/3+N/50	400/3+N/50	400/3+N/50	400/3+N/50
Maximum current input (FLA)	A	16,6	20,6	21,8	23,8	27,2

VERSION (1)		U / O	U / O	U / O	U / O	U / O
MODEL		041 P1 S	045 P1 S	039 P2 D	048 P2 D	055 P2 D
SIZE		E4	E4	E5	E5	E6
Power supply	V/ph/Hz	400/3+N/50	400/3+N/50	400/3+N/50	400/3+N/50	400/3+N/50
Maximum current input (FLA)	A	30,4	36,4	27,6	35,4	43,6

VERSION (1)		U / O	U / O	U / O	U / O	U / O
MODEL		062 P2 D	075 P2 D	082 P2 D	092 P2 D	102 P2 D
SIZE		E6	E7	E7	E8	E8
Power supply	V/ph/Hz	400/3+N/50	400/3+N/50	400/3+N/50	400/3+N/50	400/3+N/50
Maximum current input (FLA)	A	47,6	54,0	60,8	72,8	78,8

VERSION (1)		U	U
MODEL		117 P4 D	146 P4 D
SIZE		E9	E9
Power supply	V/ph/Hz	400/3+N/50	400/3+N/50
Maximum current input (FLA)	A	89,0	116,0

1. U = Under, downflow / O = Over, upflow

WARNING:

The electric data indicated refer only to the indoor unit.

Optional accessory electric data are included within the dedicated chapters and must be added.

Please refer to ELCA WORLD selection program to calculate the electrical data of the air conditioner according to the requested optional accessories.

The remote air-cooled condenser is not included because it has independent power supply.

MICROPROCESSOR CONTROL SYSTEM



Controller



Keyboard and Display

The unit is equipped with the controller connected to a 6 keys keyboard with graphic display on which all information in English language or easily identifiable symbols are displayed.
The controller disposes of a "flash" memory that preserves the information even in absence of power supply. Part of memory is dedicated to the registration of intervened events - up to 200 events.

DISPLAY – KEYBOARD FUNCTIONS

	ALARM	Alarm presence with red light. Push for alarm description. In case of more alarms scroll by UP / DOWN.
	PRG	Menu list, scrolled by UP/DOWN: Unit; Set-point; In/Out; Clock; History; User; Service; Factory. ENTER to execute.
	ESC	Home. Used to come back to the previous menu level or to the main screen.
	UP DOWN	Changes pages and values of sets. By pressing in HOME mask, the synoptic of the main controls is displayed.
	ENTER	Moving the cursor on adjustable Program(s) fields to confirm the changes. Press ENTER to get out the fields.

DISPLAY - MAIN MASK

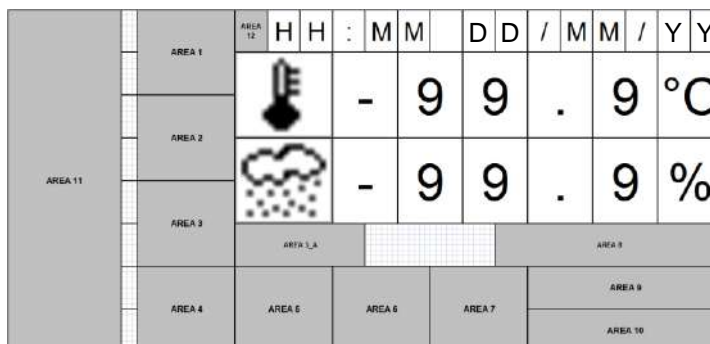

The main mask shows time, date, room temperature and humidity values (if the relative probe is present) and areas for displaying operating and alarm status with dedicated icons:

- Area 1: Status of the unit: on / off
- Area 2: Status detail
- Area 3: Type of event (only in case of an event)
- Area 3_A: Code and type of event
- Area 4: Active cooling devices
- Area 5: Active free-cooling devices
- Area 6: Active humidity devices
- Area 7: Active heating devices
- Area 8: on / off parameters
- Area 9: BMS address
- Area 10: LAN address
- Area 11: Schematic representation of units
- Area 12: Active function presence icon

CONNECTIVITY

Through the optional serial port, the microprocessor control enables communication with the modern buildings BMS systems with the following protocols: MODBUS; LON; BACNET MS/TP RS485; BACNET OVER IP.

PASSWORD

- Level 1: On request of the End User. Allowing to reach USER menu
- Level 2: Asks to Service: Allowing to reach SERVICE menu
- Level 3: Asks to Service: Allowing to reach FACTORY menu
- No passwords request to enter: UNIT, SETPOINT, IN/OUT, CLOCK, HISTORY menu

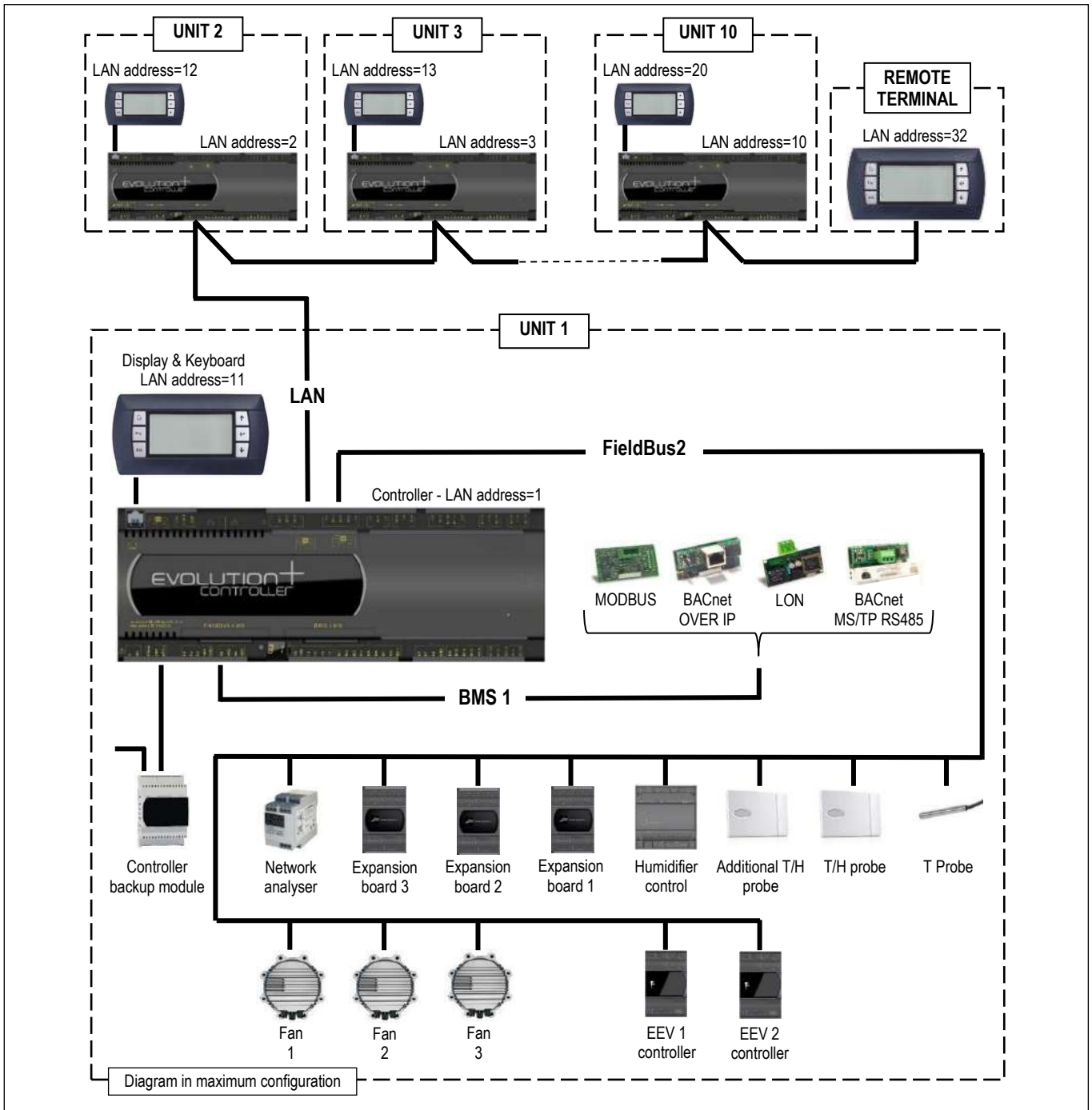

LAN NETWORK

The LAN is part of the control software and it is possible to connect up to 10 units. This type of connection allows to control the units in coherent way, moreover the units can be controlled and managed from a shared remote terminal.

LAN ADDRESS LIST

Unit #	1	2	3	4	5	6	7	8	9	10	Remote Terminal
Mother board address	1	2	3	4	5	6	7	8	9	10	--
Terminal address	11	12	13	14	15	16	17	18	19	20	32

The unit connection to the local network (LAN) allows to perform the following functions:

- Balancing the operating hours among the different units by rotating the reserve units (Stand-by)
- Turning on the reserve units in case other units should turn off due to an alarm, maintenance or power feed interruption
- Turning on reserve units to offset the excessive thermal load
- Checking up to 10 units with a single user terminal (shared user terminal)

DEMAND LIMIT

Demand Limit function is part of the control software for machines with double refrigerant circuit. It allows to limit the absorbed current of the machine.
The function must be activated and configured. A digital inlet on electrical panel connecting terminals allows the remote enabling of the function with an external signal without tension.
The software allows to select the resources to disable (compressors, electric heaters,...).

TEMPERATURE PROBE ON AIR RETURN / DELIVERY



Temperature probe installed on the air return and delivery.
Temperature control and regulation function on air return.

CLOGGED FILTERS SENSOR



The system includes a differential pressure switch installed in the electrical panel or in the front of the indoor unit and the plastic hoses for the relief of the pressure upstream and downstream the air filters.

Control range: 0.3 ... 4.0 mbar (30 ... 400 Pa)
Differential for intervention: 0.15 mbar (15 Pa)

FLOOD SENSOR



The system includes an electronic relay installed in the electrical panel of the machine and a water detector.
The electrical connections for the probe and the alarm contact are present in the machine's terminal board.
Sensor is supplied to be connected and installed at customer care.

POSSIBLE AIR INTAKE FOR OVER VERSIONS

OVER VERSION - AIR INTAKE FROM THE BOTTOM

Thanks to the particular basement design, it is possible to have the unit air intake from the bottom side. With this solution, it is necessary to foresee the optional blind frontal panels

OVER VERSION - AIR INTAKE FROM THE BACK SIDE

(Sizes E0, E4, E5, E6, E7, E8, E9 excluded)

It is possible to have the unit air intake from the back side.

Due to the limited size of the air intake, the air flow is limited to the 20% of the nominal one.

The air intake has to be made by Customer during installation.

In case the air intake is used for fresh air, it is necessary the temperature / humidity probe reposition in front of the heat exchanger, to allow for optimum reading of the values of temperature / humidity.

The electric cable of the probe has enough length for the repositioning.

AIR INTAKE FROM THE BACK SIDE

Back side view

OVER
E1 – E2 – E3

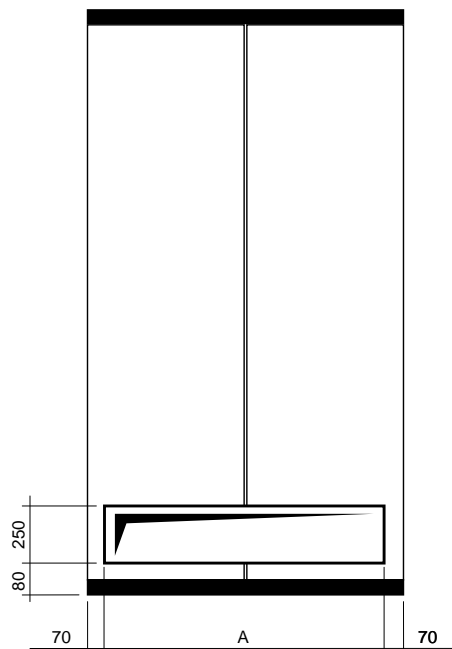

SIZE		E1	E2	E3
A	mm	510	645	945
Max air flow	m ³ /h	600	1000	1500

REMOTE AIR-COOLED CONDENSER

Remote air-cooled condensers for matching to air conditioners for IT Cooling. The constructive solutions allow high application flexibility. Horizontal air flow, from coil to fan. The series has an independent power supply from the indoor unit. Among the indoor unit and the condenser is necessary the refrigerant connection and electrical connection of the condensing proportional control signal and the alarms.

Is available the optional "P191 power supply for condenser" from the indoor machine electrical board. The optional includes magnetothermic switches for condenser fans.

GX-Z SERIES



The machines are made with Peraluman alluminum alloy and suitable for outdoor installation.

GX-Z A B 50: Remote condenser equipped with AC fan, microchannel condensing coil and Standard acoustic version.

GX-Z A L 50: Remote condenser equipped with AC fan, microchannel condensing coil and Low noise acoustic version.

GX-Z E B 50: Remote condenser equipped with EC fan, microchannel condensing coil and Standard acoustic version.

GX-Z E L 50: Remote condenser equipped with EC fan, microchannel condensing coil and Low noise acoustic version.

IMPORTANT

For further information about the units, please refer to "GX-Z" technical bulletin

BVE2 DX SERIES



The machines are made with painted steel plates and suitable for outdoor installation.

BVE2 DX-A B: Remote condenser equipped with AC fan, condensing coil with copper tubes and aluminium fins and Standard acoustic version.

BVE2 DX-A L: Remote condenser equipped with AC fan, condensing coil with copper tubes and aluminium fins and Low noise acoustic version.

BVE2 DX-E B: Remote condenser equipped with EC fan, condensing coil with copper tubes and aluminium fins and Standard acoustic version.

BVE2 DX-E L: Remote condenser equipped with EC fan, condensing coil with copper tubes and aluminium fins and Low noise acoustic version.

IMPORTANT

For further information about the units, please refer to "BVE2" technical bulletin

BVE DX-PF-E SERIES



BVE DX-PF-E: Remote air-cooled condensers equipped with EC plug fans and condensing coil with copper tubes and aluminium fins. The machines are designed for indoor installation and ducting for air suction and discharge. For outdoor installation, the machine must be installed under a cover or anyway protected against atmospheric agent.

IMPORTANT

For further information about the units, please refer to "BVE DX-PF-E" technical bulletin

WARNING:

Please refer to ELCA WORLD selection program to calculate the cooling capacity of the air conditioner according to the selected remote condenser.

OPTIONAL ACCESSORIES: P121 – FRONT AIR INTAKE+BOTTOM PANEL

Available for OVER units.

The optional is not compatible with "P122 Bottom air intake+blind panels" for OVER units.

With this accessory, it is possible a noise insulation of the machine base, when the machine is installed directly on floor as raised floor, wood floor etc.

The accessory includes:

- Panel in galvanized steel sheet.
- Noise insulation with special soundproof material.

The bottom panel is supplied assembled inside the unit base and does not modify the unit dimensions.

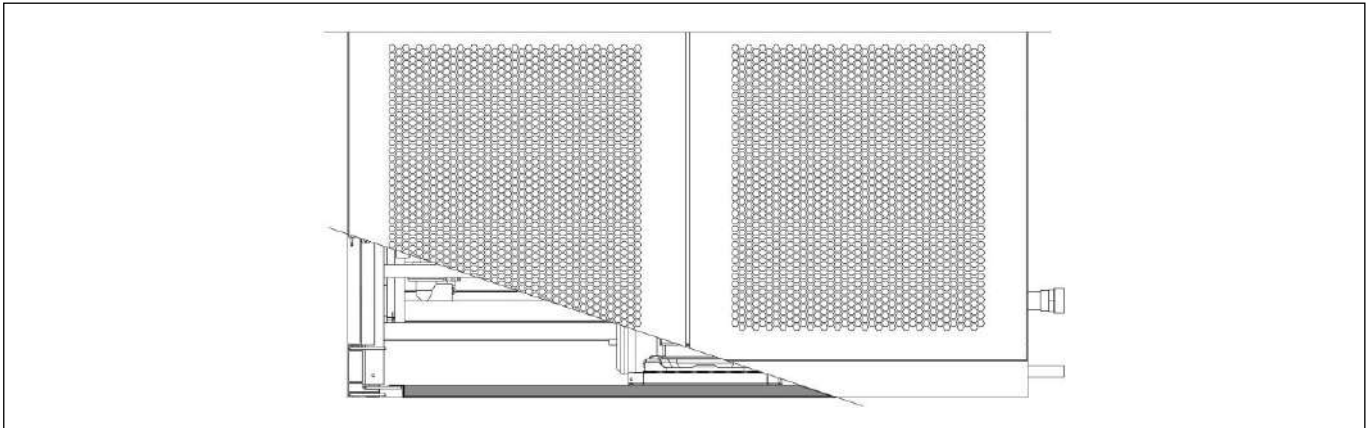

OPTIONAL ACCESSORIES: P122 - BOTTOM AIR INTAKE+BLIND PANELS

Available for OVER units.

The optional is not compatible with "P121 Front air intake+bottom panel" for OVER units.

Thanks to the design of the basement is possible the air suction from the unit bottom. The air flow rate is the nominal one

The accessory foresees the blind frontal panels.

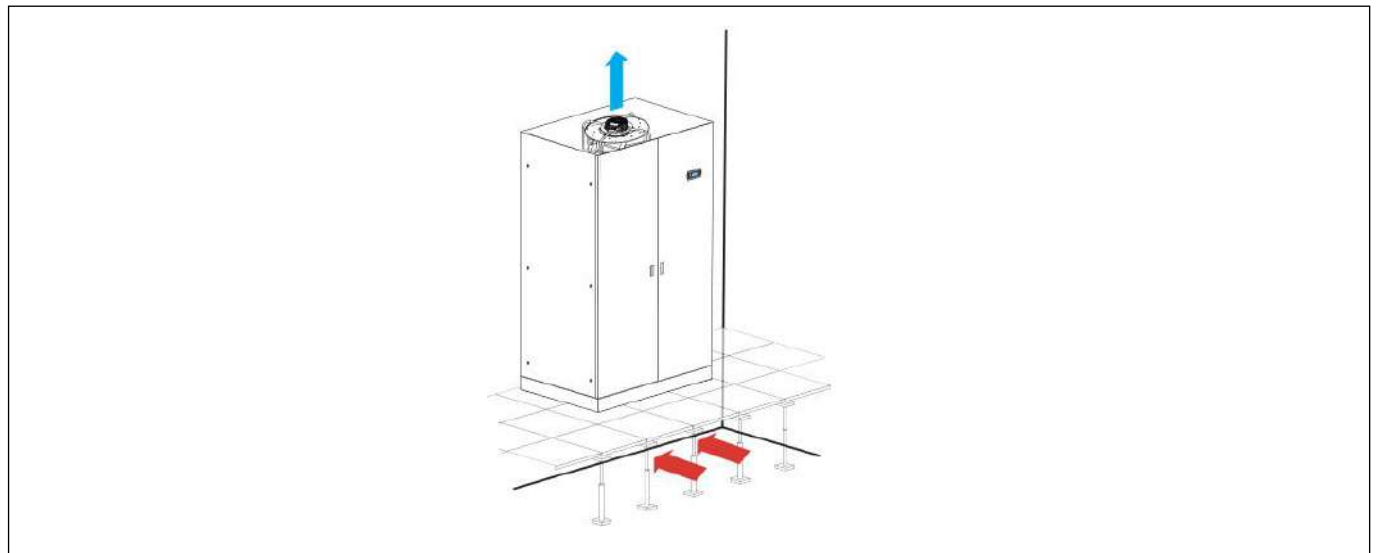

OPTIONAL ACCESSORIES: 601 – SOLENOID VALVE ON LIQUID LINE



The accessory has the function of closing the liquid line, in the event of the machine stopping or blackout, avoiding the risk of liquid refrigerant migration into the evaporator.

Recommended accessory for:

- Refrigerating lines greater than 10m in equivalent length.
- Machines equipped with electronic expansion valve.

OPTIONAL ACCESSORIES: A548 - CONSTANT PREVALENCE



The optional is a differential pressure sensor with a 0...20mA output signal. The device is installed in the machine.

The sensor is connected to the microprocessor control of the indoor unit and allows the control of:

A548 - CONSTANT PREVALENCE

The system controls the air pressure in the raised floor (Under version) or in the duct (Over version). Through the relief piping of the room pressure (low pressure side) and the air supply of the fan (high pressure side) the fan rotation speed is controlled to keep the air pressure constant.

Pressure control range from 0 to 100 Pa.

OPTIONAL ACCESSORIES: P091 - BACK-UP MODULE CONTROLLER



The optional is installed within the electrical panel.

The optional is not available for size E0, E1.

The system powers the microprocessor for a few minutes in the event of a power failure or voltage surges, preventing the re-boot of the controller.

OPTIONAL ACCESSORIES: P171 – KIT FOR AIR -45°C MCH AXIAL AC

OPTIONAL ACCESSORIES: P172 – KIT FOR AIR -45°C AXIAL AC

P171 – KIT FOR AIR -45°C MCH AXIAL AC (GX-Z A B 50)

P172 – KIT FOR AIR -45°C AXIAL AC (BVE2 DX-A B)

The optional is available only for air conditioners matched with remote air-cooled condensers with axial fans with AC electric motors:

- **BVE2 DX-A B.** Condensing coil with copper tubes and aluminium fins. Standard acoustic version, up to M140 model included.
- **GX-Z A B 50.** Condensing coil with microchannel coils. Standard acoustic version.

The system is necessary for the correct machine start up and operation with very low ambient air temperatures: between -20°C and -45°C.

Components for each refrigerant circuit:

- A check valve (YR₁), supplied in kit. The valve must be installed indoor, near to the air conditioner, on the liquid line on the return of the remote condenser. This valve avoids the migration of the refrigerant at liquid state in presence of very low ambient air condition.
- A check valve (YR₂), with controlled opening, installed in factory within the unit. It limits the pressure raising on the liquid pipe between the expansion valve and the check valve (YR₁).

Electrical components installed on the electric board of the indoor unit, only for optional accessory P172 KIT FOR AIR -45°C AXIAL AC (BVE2 DX-A B):

- Electronic phase-cut regulators for fans speed control;
- Terminals for electric connections to the remote condenser;
- Electrical power supply for remote condenser from the indoor machine electrical board.

The optional "P172 Kit for air -45°C axial AC" requires mandatory accessory "P191 Power supply for condenser".

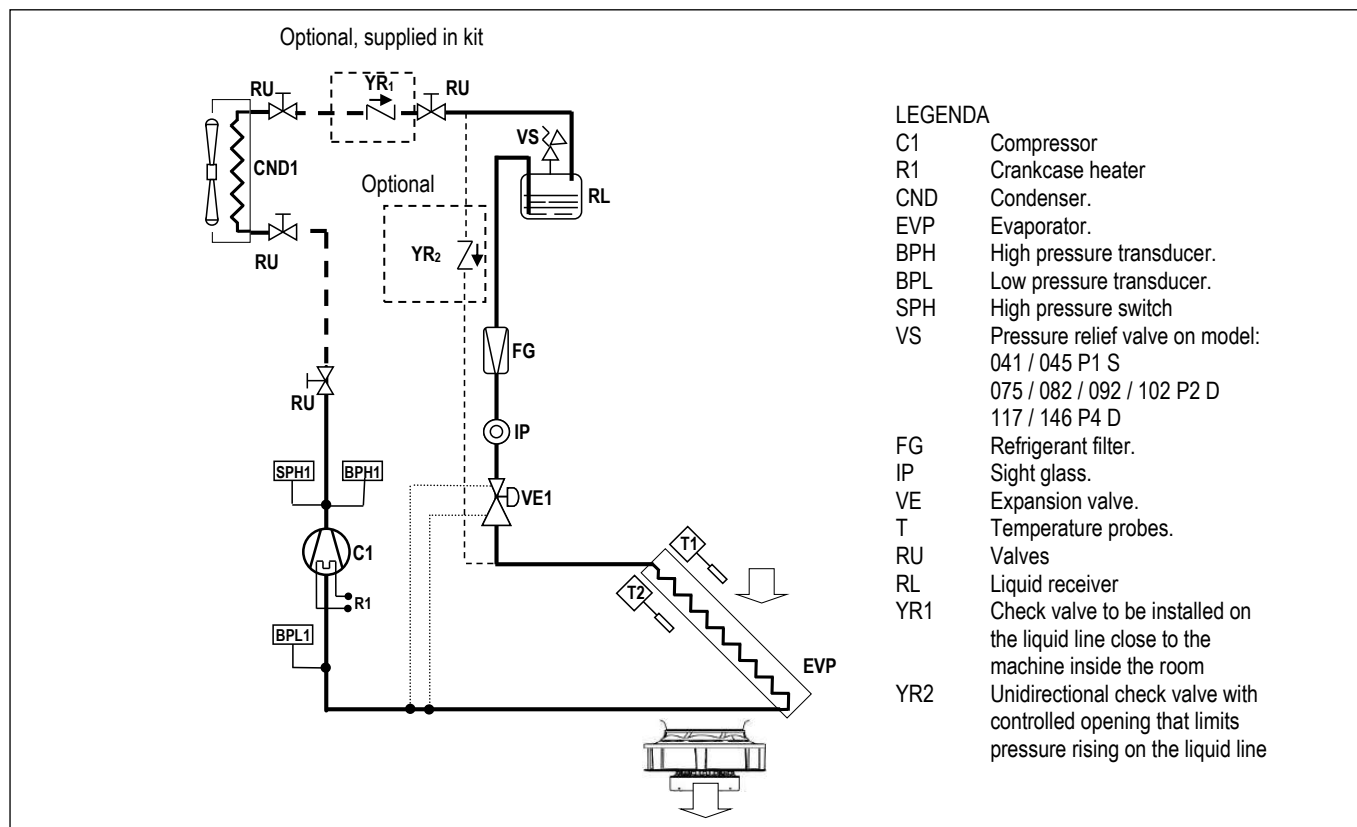

OPTIONAL ACCESSORIES: P191 – POWER SUPPLY FOR CONDENSER

The accessory allows the power supply of the remote condenser from the internal machine. The electrical panel of the internal machine is set up with the electrical control components and terminal board for the electrical connection to the condenser.

OPTIONAL ACCESSORIES: 383 – NUMBERED WIRINGS + UK REQUESTS

The machine's electrical cables are all numbered for easy identification. For the power section it is possible to change the colour for the UK market.

CABLE	383 – COLOUR FOR UK
EARTH	YELLOW / GREEN
NEUTRAL	BLUE SKY
PHASE 1 (L1)	BROWN
PHASE 2 (L2)	BLACK
PHASE 3 (L3)	GREY
AUXILIARIES	RED

OPTIONAL ACCESSORIES: 4181 – SERIAL CARD MODBUS



The card is factory installed. Consult the Interface Manual for all technical information.

OPTIONAL ACCESSORIES: 4182 – SERIAL CARD LON



The card is factory installed.
 The manufacturer will supply the serial card and .NXE file and a .XIF files necessary for LonWorks technicians to configure the network.
 The board is programmed by the technician in charge of the integration.
 Consult the Interface Manual for all technical information.

OPTIONAL ACCESSORIES: 4184 – SERIAL CARD BACNET MS/TP RS485



The card is factory installed.
 The supervision network is set up by the technicians developing the BACnet interface.
 The Modbus protocol database is used for interfacing.
 Consult the Interface Manual for all technical information.

OPTIONAL ACCESSORIES: 4185 – SERIAL CARD BACNET OVER IP



The card is factory installed.
 The supervision network is set up by the technicians developing the BACnet interface. The Modbus protocol database is used for interfacing.
 The manufacturer will supply the card and .MIB file necessary for technicians to configure the network.
 The board is programmed by the technician in charge of the integration.
 Consult the Interface Manual for all technical information and what is necessary for Internet connection to view and modify variables.

OPTIONAL ACCESSORIES: A492 – WATER LEAKAGE DETECTOR + ADDITIONAL DETECTOR



The system includes an electronic relay installed in the electrical panel of the indoor machine and 2 water detectors to be connected in series.
 The electrical connections for the probe and the alarm contact are present in the indoor machine's terminal board.
 The sensors are supplied to be connected and installed at customer care.

OPTIONAL ACCESSORIES: A511 - SMOKE DETECTORS
OPTIONAL ACCESSORIES: A521 – FIRE DETECTORS



Is possible to install one or both of the following sensors. Sensors are supplied in mounting kit. Installation within the room at customer care.

A511 - SMOKE DETECTOR

The device is supplied in mounting kit.
 The optical smoke detector senses the presence of combustion by-products (visible smoke) and activates an alarm.
 The operating principle is based on the light scattering technique (Tyndall effect).
 The device is in conformity to EN 54-7 standard.
 Technical features:

Material	ABS	Relative humidity	<93% not-condensing
Power supply	12...28 Vdc	Index of protection	IP 20
Normal current	50µA 24 Vdc	Testing by magnet	Yes
Alarm current	25mA 24 Vdc	Relay	max. 1A 30Vdc
LED visibility	360° (double led)	Signal repeater	14mA 24 Vdc
Storage temperature	-10...+70°C	Covered area	40m² max.
Operating temperature	-10...+70°C	Shielded connection	Min. 0.5 mm²
Max. speed air	0.2 m/s	Colour	White

Supplied with unit to be connected and installed at customer care close to the unit.



A521 - FIRE DETECTOR

The device is supplied in mounting kit.

The fire detector has been designed to identify temperatures at which fires may start. When the temperature exceeds the set threshold or when there is a rapid variation in temperature, the relay is activated to signal an alarm.

The device is in conformity to EN 54-5 standard.

Technical features:

Material	ABS	Index of protection	IP 20
Power supply	12...28 Vdc	Testing by magnet	Yes
Normal current	50µA 24 Vdc	Relay	max. 1A 30Vdc
Alarm current	25mA 24 Vdc	Signal repeater	14mA - 24 Vdc
LED visibility	360° (double LED)	Alarm temperature	62°C
Storage temperature	-10...+70°C	Covered area	40m ² max.
Operating temperature	-10...+70°C	Shielded connection	Min. 0.5 mm ²
Relative humidity	<93% non-condensing	Colour	White

Supplied with unit to be connected and installed at customer care close to the unit.

OPTIONAL ACCESSORIES: P141 – ANALOGUE SET-POINT COMPENSATION

Analogue set point compensation according to an external analogue signal at Customer care.

The microprocessor control, through the additional module “expansion card”, can manage a compensation signal of the return air setpoint by analogue input (0...1V; 0...5V; 0,5...4,5V; 4...20mA; 0...20mA). The compensation curve allows to assign a temperature setpoint offset respectively to the minimum and maximum signal managed by the input.

OPTIONAL ACCESSORIES: P181 – NETWORK ANALYZER

OPTIONAL ACCESSORIES: P182 – NETWORK ANALYZER+OPTIONAL

OPTIONAL ACCESSORIES: P183 – KIT NETWORK ANALYZER

OPTIONAL ACCESSORIES: P184 – KIT NETWORK ANALYZER+OPTIONAL



INTERNAL installation

The optional is not available for size E0.

This device provides continuous measurement of power consumption, monitoring current, voltage and power. These values are sent to unit microprocessor via RS485 serial cable, as shown on the unit wiring diagram.

The displayed variables are:

- Phase to phase voltage, only for three-phase units;
- Phase voltage (phase-neutral);
- Phase current;
- Neutral current only for three-phase units;
- Active phase power, only for three-phase units;
- Total active power;
- Active energy;
- Hour counts

INSTALLATION

Frame	Power Supply	Installation	Code
E0	400/3+N/50	--	--
E1	400/3+N/50	EXTERNAL to the unit, supplied in kit	P183 / P184 (*)
E2	400/3+N/50	EXTERNAL to the unit, supplied in kit	P183 / P184 (*)
E3	400/3+N/50	EXTERNAL to the unit, supplied in kit	P183 / P184 (*)
E4	400/3+N/50	INTERNAL (on unit electrical panel)	P181 / P182 (*)
E5	400/3+N/50	INTERNAL (on unit electrical panel)	P181 / P182 (*)
E6	400/3+N/50	INTERNAL (on unit electrical panel)	P181 / P182 (*)
E7	400/3+N/50	INTERNAL (on unit electrical panel)	P181 / P182 (*)
E8	400/3+N/50	INTERNAL (on unit electrical panel)	P181 / P182 (*)
E9	400/3+N/50	INTERNAL (on unit electrical panel)	P181 / P182 (*)

(*) P182, P184 for units with optional (with electric heaters and/or humidifier)



EXTERNAL installation

INTERNAL INSTALLATION

The optional is installed within the electrical box downstream the main switch with door safety lock and includes:

- Network transducer;
- Current transformers, one for each power supply phase cable.

MOUNTING KIT

The optional is supplied in box for external installation to the machine with the dimensions showed in the figure below, and includes:

- Main switch with door lock safety;
- Fuse;
- Network transducer;
- Current transformers, one for each power supply phase cable;
- Terminals.

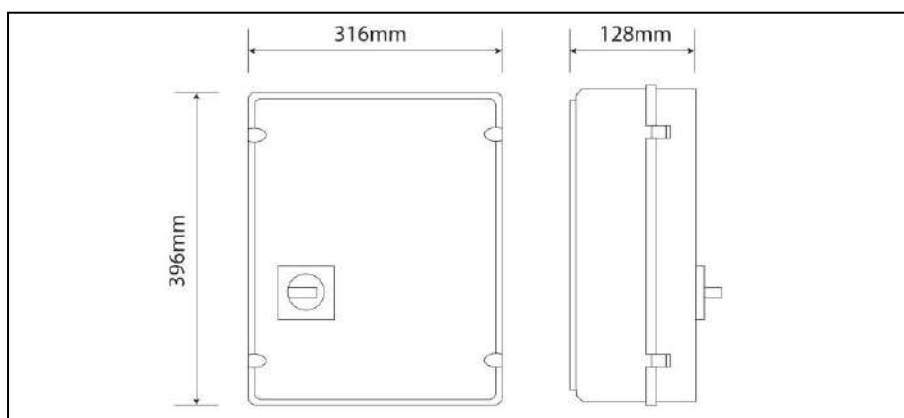

OPTIONAL ACCESSORIES: A812 – FREE-COOLING DIRECT CONTROL

Preparation of the machine and the electrical panel for the direct free-cooling system "P034 Intake free-cooling plenum "

OPTIONAL ACCESSORIES: P131 – HOT WATER COIL+2WAY VALVE



The optional is not available for size E0.
 The optional accessory is factory installed and don't modify the overall dimensions of the unit.
 The optional is not compatible with "P211 Hot gas heating+4way valve".
 Hot water heating system installed downstream the main cooling coil.

Components:

- Heat exchanger coil with internally corrugated copper tubes and high efficiency aluminium fins, specifically developed to provide high heat transfer and lower pressure drops.
- 2-way motorized valve for water flow regulation with 0÷10 VDC control actuator and emergency manual control.
- Temperature probe on water inlet.
- Frame in galvanized steel.

The hot water heating coil can be installed in combination with "A431 Electric heaters". The operation is alternate with priority to the hot water heating coil.

TECHNICAL DATA

VERSION (1)		U / O	U / O	U / O	U / O	U / O	U / O
MODEL		007 P1 S	009 P1 S	011 P1 S	014 P1 S	016 P1 S	020 P1 S
SIZE		E0	E0	E1	E2	E2	E3
THERMAL CAPACITY (2)	kW	-	-	24,8	34,9	36,0	47,0
HEATING COIL							
Water flow rate (2)	m ³ /h	-	-	2,16	3,06	3,17	4,10
dP coil + valve (2)	kPa	-	-	26,6	25,2	26,3	24,8
Water volume	l	-	-	2,6	2,6	2,6	3,9
NET WEIGHT (3)	kg	-	-	15	18	18	25
HYDRAULIC CONNECTIONS							
WATER INLET / OUTLET ISO 7/1 - R	Ø	-	-	3/4"	3/4"	3/4"	1"

VERSION (1)		U / O	U / O	U / O	U / O	U / O	U / O
MODEL		022 P1 S	026 P1 S	032 P1 S	037 P1 S	041 P1 S	045 P1 S
SIZE		E3	E3	E4	E4	E4	E4
THERMAL CAPACITY (2)	kW	49,2	50,7	76,3	83,9	88,3	88,3
HEATING COIL							
Water flow rate (2)	m ³ /h	4,32	4,46	6,70	7,34	7,74	7,74
dP coil + valve (2)	kPa	26,4	27,5	9,3	10,4	11,1	11,1
Water volume	l	3,9	3,9	6,9	6,9	6,9	6,9
NET WEIGHT (3)	kg	25	25	35	35	35	35
HYDRAULIC CONNECTIONS							
WATER INLET / OUTLET ISO 7/1 - R	Ø	1"	1"	1+1/4"	1+1/4"	1+1/4"	1+1/4"

VERSION (1)		U / O	U / O	U / O	U / O	U / O	U / O
MODEL		039 P2 D	048 P2 D	055 P2 D	062 P2 D	075 P2 D	082 P2 D
SIZE		E5	E5	E6	E6	E7	E7
THERMAL CAPACITY (2)	kW	96,6	103,0	130,0	134,0	155,0	155,0
HEATING COIL							
Water flow rate (2)	m ³ /h	8,46	9,00	11,45	11,74	13,61	13,61
dP coil + valve (2)	kPa	19,2	21,1	35,0	36,3	6,9	6,9
Water volume	l	9,1	9,1	10,6	10,6	12,3	12,3
NET WEIGHT (3)	kg	42	42	50	50	57	57
HYDRAULIC CONNECTIONS							
WATER INLET / OUTLET ISO 7/1 - R	Ø	1+1/2"	1+1/2"	1+1/2"	1+1/2"	2"	2"

1. U = Under, downflow / O = Over, upflow
2. Characteristics referred to entering air at 20°C-50%UR with hot water temperature 70/60°C - 0% glycol.
3. Value to be added to the weight of the standard unit. Does not include the weight of the water content.

TECHNICAL DATA

VERSION (1)		U / O	U / O	U	U
MODEL		092 P2 D	102 P2 D	117 P4 D	146 P4 D
SIZE		E8	E8	E9	E9
THERMAL CAPACITY (2)	kW	175,0	175,0	237,0	237,0
HEATING COIL					
Water flow rate (2)	m ³ /h	15,37	15,37	20,7	20,7
dP coil + valve (2)	kPa	9,6	9,6	20,4	20,4
Water volume	l	14,2	14,2	16,9	16,9
NET WEIGHT (3)	kg	65	65	75	75
HYDRAULIC CONNECTIONS					
WATER INLET / OUTLET	ISO 7/1 - R Ø	2"	2"	2"	2"

1. U = Under, downflow / O = Over, upflow

2. Characteristics referred to entering air at 20°C-50%UR with hot water temperature 70/60°C - 0% glycol.

3. Value to be added to the weight of the standard unit. Does not include the weight of the water content.

2-WAY BALL VALVE FOR HOT WATER FLOW CONTROL



The water flow control in the finned coil is achieved through a **2-way modulating ball valve with equal percentage flow control** ensured by the integrated characterizing disc.

This type of valve offers the following series of benefits:

- Equal percentage flow control.
- No peaks initial flow.
- Excellent stability control thanks to the integrated characterizing disc.
- Excellent characteristic in partialisation.
- Stability in control.
- Maintenance free.
- Self-cleaning.

CHARACTERISTICS OF THE 2-WAY BALL VALVE

- Closing seal with leakage rate in Class A (EN 12266-1)
- Maximum fluid pressure $P_s=1600\text{kPa}$
- Maximum closing pressure (Close-off) $\Delta P_s=1400\text{kPa}$

The rotative actuator is controlled by a signal 0 ... 10VDC from the microprocessor controller. The actuator is equipped with an emergency button for manual operation and is maintenance-free.

HOT WATER HEATING HYDRAULIC / REFRIGERANT CIRCUIT

UNDER - SINGLE REFRIGERANT CIRCUIT

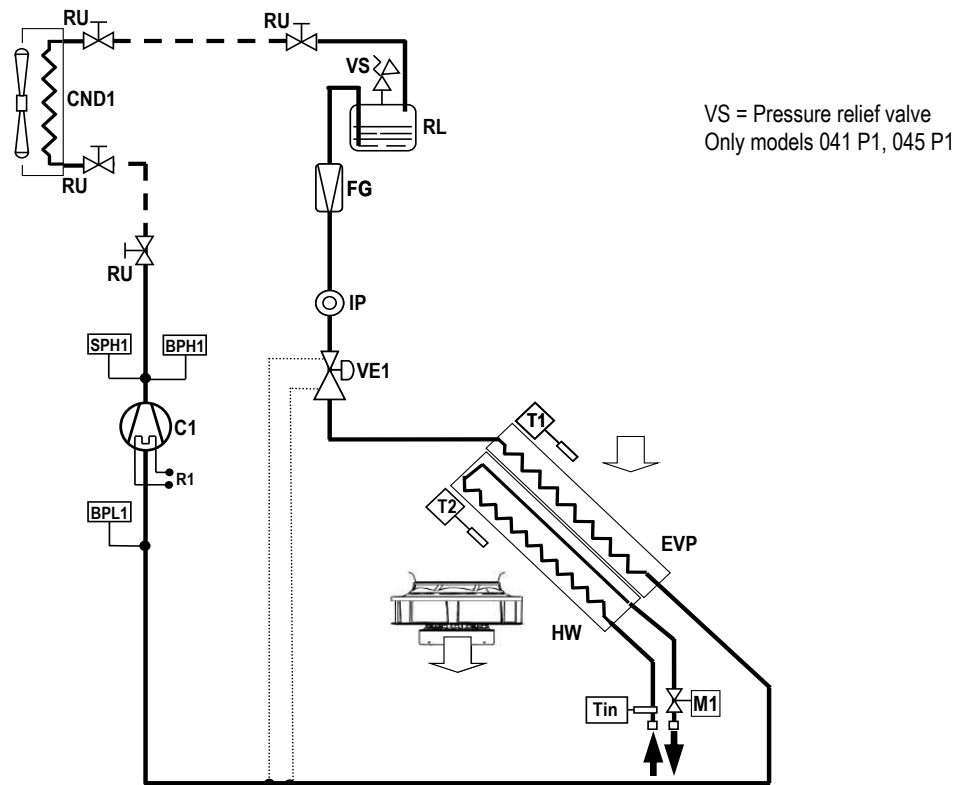

OVER - SINGLE REFRIGERANT CIRCUIT

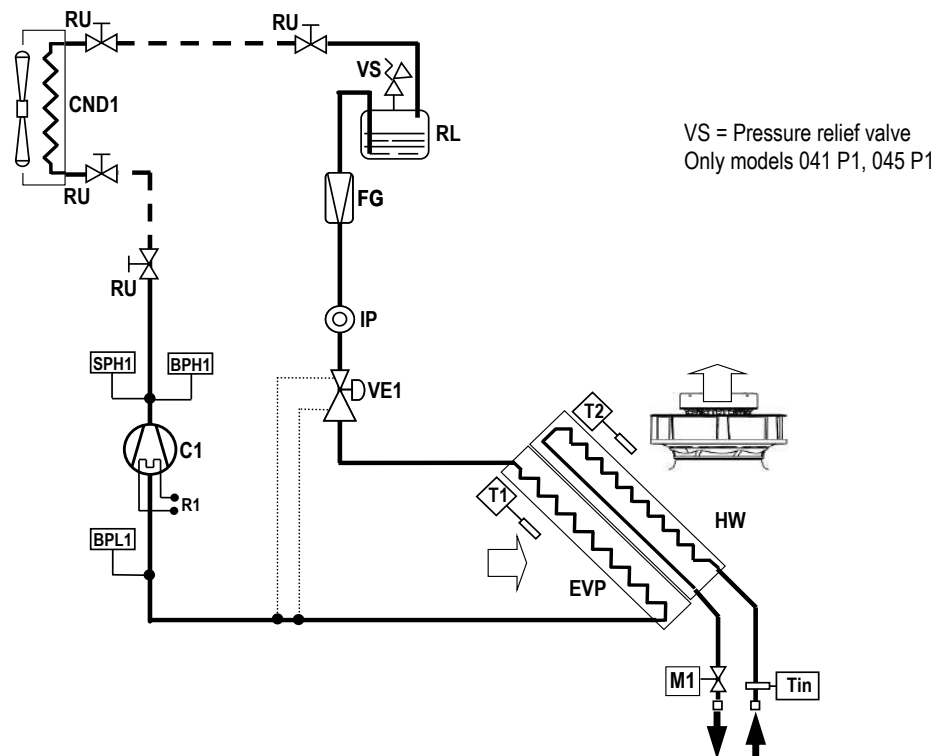

LEGENDA

- | | | | | | |
|-----|------------------|-----|---------------------------|----|---------------------|
| C1 | Compressor | BPH | High pressure transducer. | IP | Sight glass. |
| R1 | Crankcase heater | BPL | Low pressure transducer. | VE | Expansion valve. |
| CND | Condenser. | SPH | High pressure switch | T | Temperature probes. |
| EVP | Evaporator | M1 | Hot water 2-way valve | RU | Valves |
| HW | Hot water coil | VS | Pressure relief valve. | RL | Liquid receiver |
| | | FG | Refrigerant filter. | | |

HOT WATER HEATING HYDRAULIC / REFRIGERANT CIRCUIT

UNDER - DOUBLE REFRIGERANT CIRCUIT

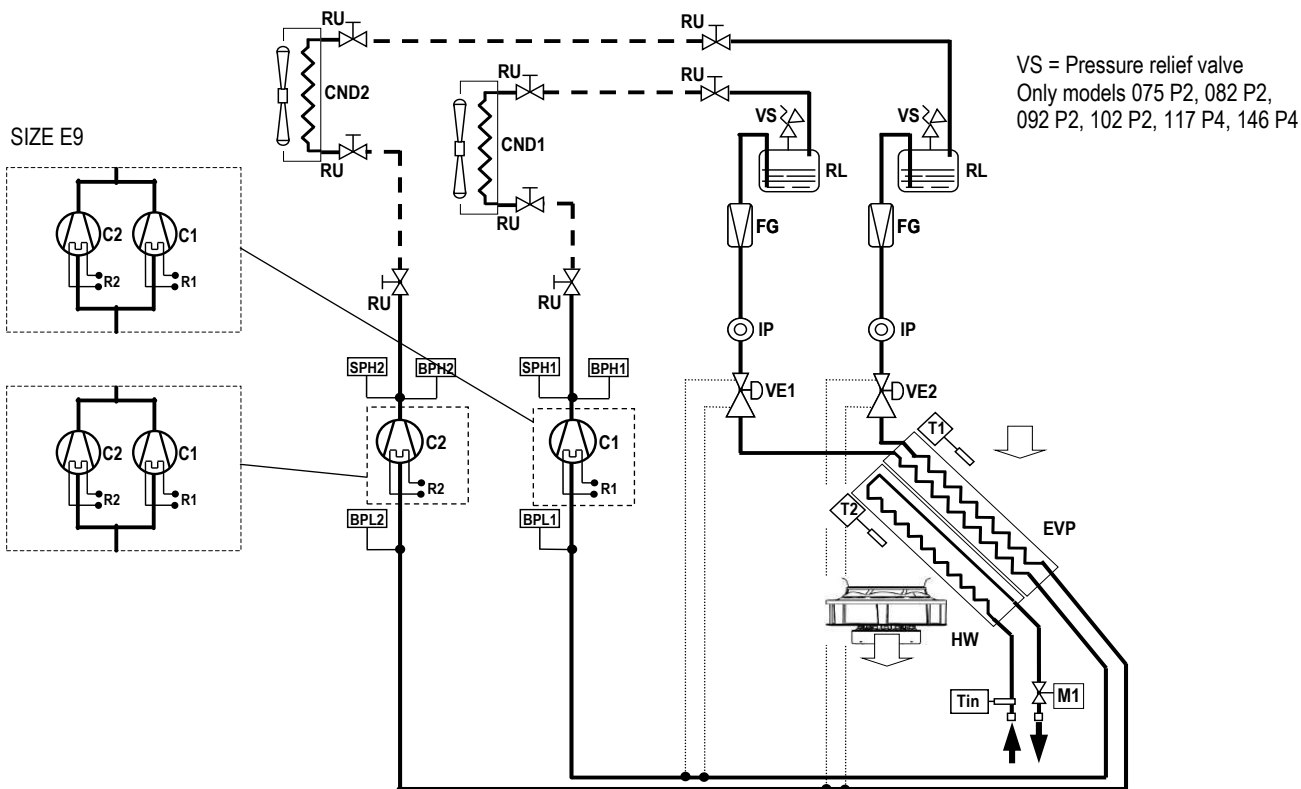

OVER - DOUBLE REFRIGERANT CIRCUIT

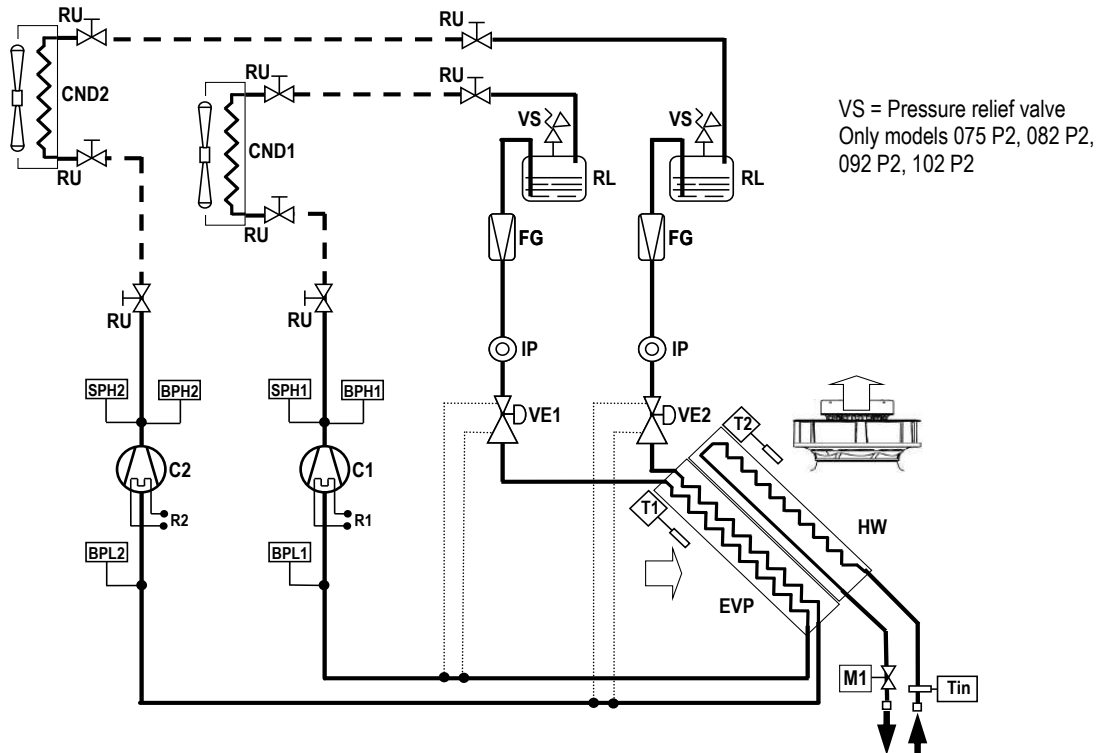

LEGENDA

- C1...2 Compressor 1, 2
- R1...2 Crankcase heater 1, 2
- CND Condenser.
- EVP Evaporator
- HW Hot water coil

- BPH High pressure transducer.
- BPL Low pressure transducer.
- SPH High pressure switch
- M1 Hot water 2-way valve
- VS Pressure relief valve.
- FG Refrigerant filter.

- IP Sight glass.
- VE Expansion valve.
- T Temperature probes.
- RU Valves
- RL Liquid receiver

WATER QUALITY OF THE HYDRAULIC CIRCUITS

The values shown in the table must be guaranteed during the entire life cycle of the machine.

	Description	Symbol	Range
1	Hydrogen Ions	pH	7.5 ÷ 9
2	Presence of calcium (Ca) and magnesium (Mg)	Hardness	4 ÷ 8.5 °D
3	Chlorine ions	Cl ⁻	< 150 ppm
4	Iron Ions	Fe ³⁺	< 0.5 ppm
5	Manganese Ions	Mn ²⁺	< 0.05 ppm
6	Carbon dioxide	CO ₂	< 10 ppm
7	Hydrogen sulphide	H ₂ S	< 50 ppb
8	Oxygen	O ₂	< 0.1 ppm
9	Chlorine	Cl ₂	< 0.5 ppm
10	Ammonia	NH ₃	< 0.5 ppm
11	Ratio between carbonates and sulphates	HCO ₃ ⁻ /SO ₄ ²⁻	> 1
12	Sulphate ions	SO ₄ ⁻	< 100 ppm
13	Phosphate ions	PO ₄ ³⁻	< 2.0 ppm

where: $1/1.78^{\circ}\text{D} = 1^{\circ}\text{Fr}$ with $1^{\circ}\text{Fr} = 10 \text{ gr CaCO}_3 / \text{m}^3$

ppm = parts for millions

ppb = part for billion

Explanatory notes:

- ref.1: A greater concentration of hydrogen ions (pH) than 9 implies a high risk of deposits, whereas a lower pH than 7 implies a high risk of corrosion.
- ref.2: The hardness measures the amount of Ca and Mg carbonate dissolved in the water with a temperature lower than 100°C (temporary hardness). A high hardness implies a high risk of deposits.
- ref.3: The concentration of chloride ions with higher values than those indicated causes corrosion.
- ref. 4 - 5 - 8: The presence of iron and manganese ions and oxygen leads to corrosion.
- ref.6 - 7: Carbon dioxide and hydrogen sulphide are impurities that promote corrosion.
- ref.9: Usually in water from the waterworks it is a value of between 0.2 and 0.3 ppm. High values cause corrosion.
- ref.10: The presence of ammonia reinforces the oxidising power of oxygen
- ref.11: Below the value shown in the table, there is a risk of corrosion due to the trigger of galvanic currents between copper and other less noble metals.
- ref.12: The presence of sulphates ions triggers corrosion phenomenon.
- ref.13: The presence of phosphates ions triggers corrosion phenomenon.

It is necessary to carry out periodic checks, with withdrawals at different points of the hydraulic system. During the first year of operation, checks are recommended every 4 months which can be reduced every 6 months starting from the second year of operation.

WARNING:

Values of the parameters outside the indicated ranges can lead to the formation of deposits and limescale and/or favour corrosive phenomena within the plant. For operating fluids other than water (mixtures of ethylene and propylene glycol) it is recommended to use specific inhibitors, designed to offer thermal stability within the operating temperature range and protection against corrosion. It is necessary that, in the presence of dirty and / or aggressive waters, an intermediate heat exchanger is installed upstream of the heat exchangers.

ANTIFREEZE MIXTURES

In plants that are not adequately protected by heating cables, protect the hydraulic circuit with an anti-freeze mixture when the ambient air temperature can drop below 5°C.

Minimum ambient air temperature	°C	5	0	-5	-10	-15	-20	-25	-30
ETHYLENE GLYCOL (suggested % in weight)	%	0	12	20	30	35	40	45	50

Minimum ambient air temperature	°C	5	2	-3	-9	-13	-17	-23	-29
PROPYLENE GLYCOL (suggested % in weight)	%	0	10	20	30	35	40	45	50

The values are indicative and may significantly vary depending on the glycol manufacturer. Refer to your glycol supplier for detail.

The values consider a precautionary difference of 5°C between the minimum ambient air temperature and the freezing temperature of the mixture.

In the hydraulic circuit do not send fluids other than water or mixtures with ethylene / propylene glycol.

If other products are provided, in addition to mixtures of water and ethylene or propylene glycol, contact the Manufacturer to check the compatibility with the machine components.

OPTIONAL ACCESSORIES: P211 - HOT GAS HEATING+4WAY VALVE



The optional is not available for size E0, E5, E6, E7, E8, E9.
 The optional is not compatible with "P131 Hot water coil+2way valve".
 The optional requires mandatory accessories "P051 Dehumidification function" and "P161 T/rH air intake sensor".

On-off type hot gas re-heating system.
 In presence of normal or extraordinary variations of the room thermal load, it can be necessary to control an increase in the relative humidity value, by adding sensible heat to the pre-cooled and pre-dehumidified air.
 To achieve this result, it is possible to take advantage of part of the heat of condensation given by the operation of the cooling circuit which has to be dissipated anyway.
 This system is energy conscious since it does not require any other electric energy but that already consumed by the compressor.
 The necessary heat is obtained by the partial deviation of the compressor hot gas discharge into heat exchange coil, installed downstream the cooling coil, so that heat is transferred to the air being handled.
 The gas is then brought back into the main circuit via the dissipation system (air cooled or water-cooled condenser).
 It is equipped with ON/OFF control of the quantity of heat provided by the re-heating coil.
 The system looks like a derivation of the main gas circuit and it is formed by a 4-way valve positioned on the compressor discharge side.
 Heat transfer is achieved through a heat exchanger placed immediately after the evaporating coil.
 Upon a re-heating request from the microprocessor control system, the 4-way valve divert the hot gas through the re-heating coil.
 This causes a temperature increase in the leaving air from the evaporating coil.
 The refrigerant gas is then brought to the condenser and then back to the evaporating coil.
 During normal working conditions, the 4-way valve does not allow the passage of the hot gas through the re-heating coil by ensuring it enters directly into the condensing system.
 In case of failure of the 4-way valve, the valve automatically positions itself to completely exclude the re-heating system.

The system is not available for machines with double refrigerant circuit.

The hot gas re-heating system can be installed in combination with the "A431 Electric heaters". The operation is alternate with priority to the hot gas re-heating system. In this configuration the electric heater groups the operating stages in a single step.

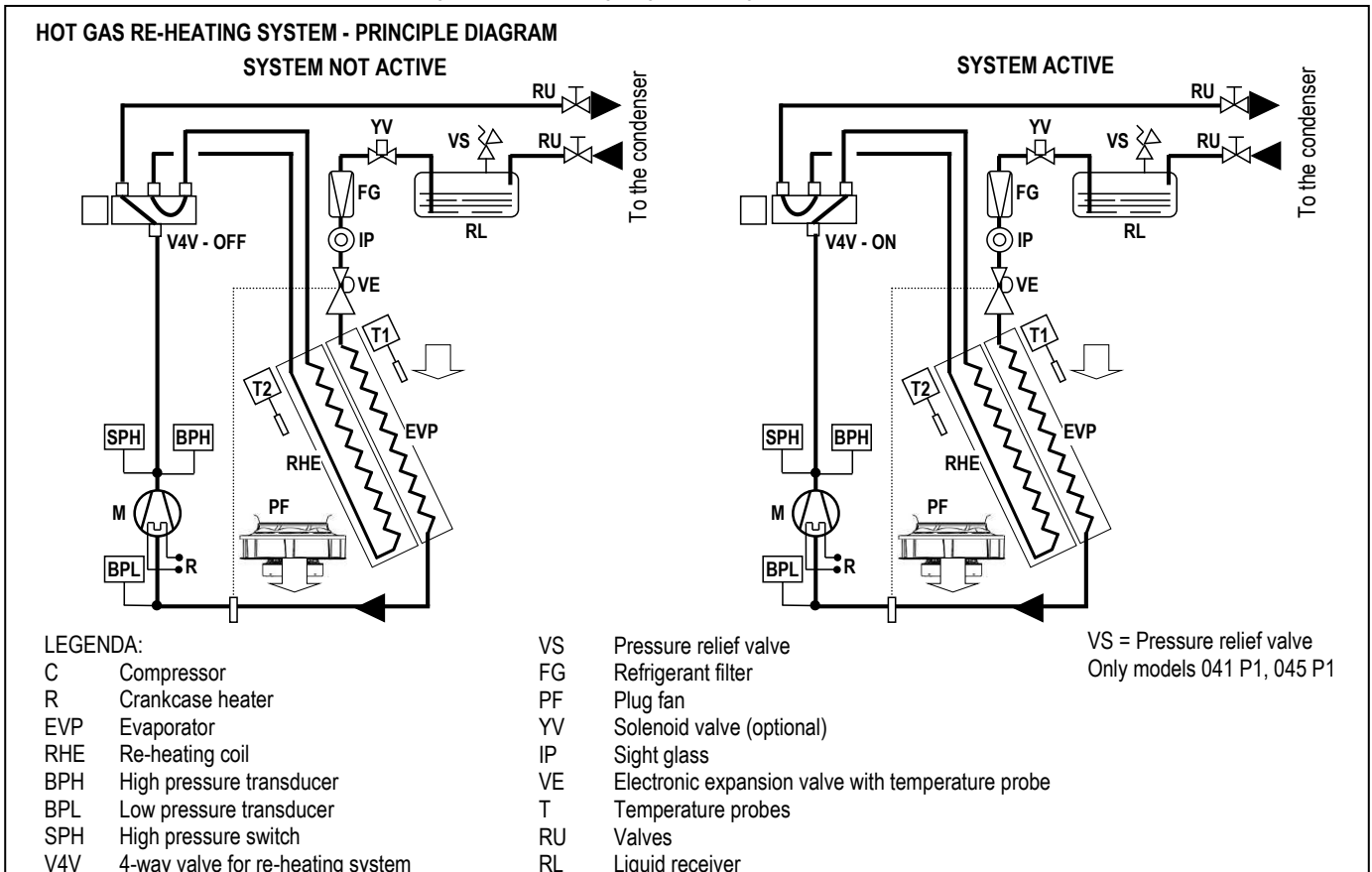

TECHNICAL DATA

VERSION (1)		U / O	U / O	U / O	U / O	U / O	U / O
MODEL		007 P1 S	009 P1 S	011 P1 S	014 P1 S	016 P1 S	020 P1 S
SIZE		E0	E0	E1	E2	E2	E3
HEATING CAPACITY	kW	--	--	7,8	10,8	11,5	15,8

VERSION (1)		U / O	U / O	U / O	U / O	U / O	U / O
MODEL		022 P1 S	026 P1 S	032 P1 S	037 P1 S	041 P1 S	045 P1 S
SIZE		E3	E3	E4	E4	E4	E4
HEATING CAPACITY	kW	17,2	19,4	25,0	28,9	31,6	33,0

VERSION (1)		U / O	U / O	U / O	U / O	U / O	U / O
MODEL		039 P2 D	048 P2 D	055 P2 D	062 P2 D	075 P2 D	082 P2 D
SIZE		E5	E5	E6	E6	E7	E7
HEATING CAPACITY	kW	--	--	--	--	--	--

VERSION (1)		U / O	U / O	U	U
MODEL		092 P2 D	102 P2 D	117 P4 D	146 P4 D
SIZE		E8	E8	E9	E9
HEATING CAPACITY	kW	--	--	--	--

1. U = Under, downflow / O = Over, upflow

The optional accessory modifies the weight of the standard unit.

OPTIONAL ACCESSORIES: A431 – ELECTRIC HEATERS

OPTIONAL ACCESSORIES: A432 – EXTRA POWER ELECTRIC HEATERS

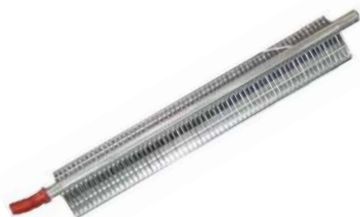

A431 –ELECTRIC HEATERS

Electric heater consisting of finned aluminium elements, ensuring low surface temperature and deleting the air ionization problems. The optional is installed downstream the main cooling coil.

In electric heaters with three working steps the activation is binary type.

Components:

- Electric heater in aluminium armoured elements with integral fins
- Electrical control
- Safety thermostat.

The electric heater can be installed in combination with "P131 Hot water coil+2way valve". The operation is alternate with priority to the hot water heating coil.

The electric heater can be installed in combination with "P211 Hot gas heating+4way valve". The operation is alternate with priority to the hot gas re-heating system. In this configuration the electric heater groups the operating stages in a single step.

TECHNICAL DATA

VERSION (1)		U / O	U / O	U / O	U / O	U / O	U / O
MODEL		007 P1 S	009 P1 S	011 P1 S	014 P1 S	016 P1 S	020 P1 S
SIZE		E0	E0	E1	E2	E2	E3
THERMAL CAPACITY	kW	2,5	2,5	5,1	5,1	5,1	6,0
Absorbed current (OA)	A	3,6	3,6	7,4	7,4	7,4	8,7
First working step	kW	2,5	2,5	5,1	5,1	5,1	3,0
Second working step	kW	-	-	-	-	-	3,0+3,0
Third working step	kW	-	-	-	-	-	-
NET WEIGHT (2)	kg	3	3	4	4	4	7

VERSION (1)		U / O	U / O	U / O	U / O	U / O	U / O
MODEL		022 P1 S	026 P1 S	032 P1 S	037 P1 S	041 P1 S	045 P1 S
SIZE		E3	E3	E4	E4	E4	E4
THERMAL CAPACITY	kW	6,0	6,0	9,0	9,0	9,0	9,0
Absorbed current (OA)	A	8,7	8,7	13,0	13,0	13,0	13,0
First working step	kW	3,0	3,0	3,0	3,0	3,0	3,0
Second working step	kW	3,0+3,0	3,0+3,0	6,0	6,0	6,0	6,0
Third working step	kW	--	--	3,0+6,0	3,0+6,0	3,0+6,0	3,0+6,0
NET WEIGHT (2)	kg	7	7	9,5	9,5	9,5	9,5

VERSION (1)		U / O	U / O	U / O	U / O	U / O	U / O
MODEL		039 P2 D	048 P2 D	055 P2 D	062 P2 D	075 P2 D	082 P2 D
SIZE		E5	E5	E6	E6	E7	E7
THERMAL CAPACITY	kW	13,5	13,5	13,5	13,5	13,5	13,5
Absorbed current (OA)	A	19,5	19,5	19,5	19,5	19,5	19,5
First working step	kW	4,5	4,5	4,5	4,5	4,5	4,5
Second working step	kW	9,0	9,0	9,0	9,0	9,0	9,0
Third working step	kW	4,5+9,0	4,5+9,0	4,5+9,0	4,5+9,0	4,5+9,0	4,5+9,0
NET WEIGHT (2)	kg	10	10	9,5	9,5	9,5	9,5

VERSION (1)		U / O	U / O	U	U
MODEL		092 P2 D	102 P2 D	117 P4 D	146 P4 D
SIZE		E8	E8	E9	E9
THERMAL CAPACITY	kW	18,0	18,0	18,0	18,0
Absorbed current (OA)	A	26,0	26,0	26,0	26,0
First working step	kW	4,5	4,5	4,5	4,5
Second working step	kW	13,5	13,5	13,5	13,5
Third working step	kW	4,5+13,5	4,5+13,5	4,5+13,5	4,5+13,5
NET WEIGHT (2)	kg	11	11	11	11

1. U = Under, downflow / O = Over, upflow
2. Value to be added to the weight of the standard unit.

A432 – EXTRA POWER ELECTRIC HEATERS

The optional is not available for sizes E0, E1, E2.

The components are the same of the standard accessory

It is not possible to combine the extra power electric heaters with "P131 Hot water coil+2way valve" and "P211 Hot gas heating+4way valve".

TECHNICAL DATA

VERSION (1)		U / O	U / O	U / O	U / O	U / O	U / O
MODEL		007 P1 S	009 P1 S	011 P1 S	014 P1 S	016 P1 S	020 P1 S
SIZE		E0	E0	E1	E2	E2	E3
THERMAL CAPACITY	kW	--	--	--	--	--	9,0
Absorbed current (OA)	A	--	--	--	--	--	13,0
First working step	kW	--	--	--	--	--	4,5
Second working step	kW	--	--	--	--	--	4,5+4,5
Third working step	kW	--	--	--	--	--	-
NET WEIGHT (2)	kg	--	--	--	--	--	7

VERSION (1)		U / O	U / O	U / O	U / O	U / O	U / O
MODEL		022 P1 S	026 P1 S	032 P1 S	037 P1 S	041 P1 S	045 P1 S
SIZE		E3	E3	E4	E4	E4	E4
THERMAL CAPACITY	kW	9,0	9,0	13,5	13,5	13,5	13,5
Absorbed current (OA)	A	13,0	13,0	13,0	13,0	13,0	13,0
First working step	kW	4,5	4,5	4,5	4,5	4,5	4,5
Second working step	kW	4,5+4,5	4,5+4,5	9,0	9,0	9,0	9,0
Third working step	kW	-	-	4,5+9,0	4,5+9,0	4,5+9,0	4,5+9,0
NET WEIGHT (2)	kg	7	7	9,5	9,5	9,5	9,5

VERSION (1)		U / O	U / O	U / O	U / O	U / O	U / O
MODEL		039 P2 D	048 P2 D	055 P2 D	062 P2 D	075 P2 D	082 P2 D
SIZE		E5	E5	E6	E6	E7	E7
THERMAL CAPACITY	kW	18,0	18,0	18,0	18,0	18,0	18,0
Absorbed current (OA)	A	26,0	26,0	26,0	26,0	26,0	26,0
First working step	kW	4,5	4,5	4,5	4,5	4,5	4,5
Second working step	kW	13,5	13,5	13,5	13,5	13,5	13,5
Third working step	kW	4,5+13,5	4,5+13,5	4,5+13,5	4,5+13,5	4,5+13,5	4,5+13,5
NET WEIGHT (2)	kg	12	12	11,5	11,5	11,5	11,5

VERSION (1)		U / O	U / O	U	U
MODEL		092 P2 D	102 P2 D	117 P4 D	146 P4 D
SIZE		E8	E8	E9	E9
THERMAL CAPACITY	kW	27,0	27,0	27,0	27,0
Absorbed current (OA)	A	39,0	39,0	39,0	39,0
First working step	kW	9,0	9,0	9,0	9,0
Second working step	kW	18,0	18,0	18,0	18,0
Third working step	kW	9,0+18,0	9,0+18,0	9,0+18,0	9,0+18,0
NET WEIGHT (2)	kg	14,5	14,5	14,5	14,5

1. U = Under, downflow / O = Over, upflow
2. Value to be added to the weight of the standard unit.

OPTIONAL ACCESSORIES: 4301 – STEAM HUMIDIFIER 3KG/H
OPTIONAL ACCESSORIES: 4303 – STEAM HUMIDIFIER 8KG/H
OPTIONAL ACCESSORIES: 4305 – STEAM HUMIDIFIER 15KG/H

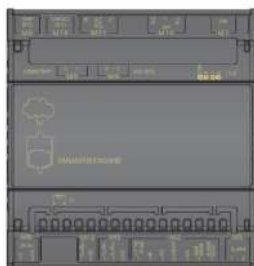

Humidifier control board

Modulating steam humidifier with immersed electrodes fitted with safety and running accessories
 The optional includes the control board.

The optional requires mandatory accessory "P161 T/rH air intake sensor".

The optional is factory installed and requires only water filling connection.

Humidifier water charge and discharge pipes are not supplied.

It is recommended to install a filter and a shut-off valve on the pipe to the water inlet.

This humidifier produces non-pressurized steam by electrodes immersed in the water inside the cylinder: they bring the electric phase in the water that works as an electrical resistance and overheats. The steam so produced is distributed with dedicated distributors and used for ambient humidification or for industrial processes.

CHARACTERISTICS OF THE SUPPLY WATER

The quality of the used water influences the evaporation process, so the humidifier can be fed with **not-treated water, only when potable and non-demineralised.**

LIMIT VALUES

		Min	Max
Hydrogen ions	pH	7	8,5
Specific conductivity at 20°C	$\sigma_{R, 20^\circ C}$ $\mu S/cm$	350	750
Total dissolved solids	TDS mg/l	(1)	(1)
Dry residue at 180°C	R ₁₈₀ mg/l	(1)	(1)
Total hardness	TH mg/l CaCO ₃	100 (2)	400
Temporary hardness	mg/l CaCO ₃	60 (3)	300
Iron + Manganese	mg/l Fe + Mn	0	0,2
Chlorides	ppm Cl	0	30
Silica	mg/l SiO ₂	0	20
Residual chlorine	mg/l Cl ⁻	0	0,2
Calcium sulphate	mg/l CaSO ₄	0	100
Metallic impurities	mg/l	0	0
Solvents, diluents, soaps, lubricants	mg/l	0	0

(1) Values depending on specific conductivity; in general: TDS \cong 0,93 * $\sigma_{R, 20^\circ C}$; R₁₈₀ \cong 0,65 * $\sigma_{R, 20^\circ C}$

(2) Not lower than 200% of the chloride content in mg/l di Cl⁻

(3) Not lower than 300% of the chloride content in mg/l di Cl⁻

WARNING:

- Use only with drinking water.
- There is no reliable relationship between hardness and water conductivity
- Do not treat water with softeners! This could cause corrosion of the electrodes or the formation of foam, leading to potential operating problems or failures.
- Do not add disinfectants or corrosion inhibitors to water, as these substances are potentially irritant.
- Is absolutely forbidden to use well water, industrial water or water drawn from cooling circuits; in general, avoid using potentially contaminated water, either from a chemical or bacteriological point of view.

TECHNICAL DATA

VERSION (1)		U / O	U / O	U / O	U / O	U / O	U / O
MODEL		007 P1 S	009 P1 S	011 P1 S	014 P1 S	016 P1 S	020 P1 S
SIZE		E0	E0	E1	E2	E2	E3
STEAM PRODUCTION	kg/h	3,0	3,0	3,0	3,0	3,0	3,0
Power input	kW	2,3	2,3	2,3	2,3	2,3	2,3
Absorbed current (OA)	A	3,2	3,2	3,2	3,2	3,2	3,2
Max absorbed current (FLA)	A	4,5	4,5	4,5	4,5	4,5	4,5
Water content	l	3,9	3,9	3,9	3,9	3,9	3,9
Max water supply pressure	Bar	1÷8	1÷8	1÷8	1÷8	1÷8	1÷8
NET WEIGHT (2)	kg	4	5	4	5	5	6
HYDRAULIC CONNECTION							
WATER INLET - ISO 228/1 – G M	Ø	3/4"	3/4"	3/4"	3/4"	3/4"	3/4"
WATER OUTLET - external diameter	Ø mm	19	19	19	19	19	19

1. U = Under, downflow / O = Over, upflow

2. Value to be added to the weight of the standard unit. Does not include the weight of the water content.

TECHNICAL DATA

VERSION (1)		U / O	U / O	U / O	U / O	U / O	U / O
MODEL		022 P1 S	026 P1 S	032 P1 S	037 P1 S	041 P1 S	045 P1 S
SIZE		E3	E3	E4	E4	E4	E4
STEAM PRODUCTION	kg/h	3,0	3,0	8,0	8,0	8,0	8,0
Power input	kW	2,3	2,3	6,0	6,0	6,0	6,0
Absorbed current (OA)	A	3,2	3,2	8,7	8,7	8,7	8,7
Max absorbed current (FLA)	A	4,5	4,5	12,4	12,4	12,4	12,4
Water content	l	3,9	3,9	6,0	6,0	6,0	6,0
Max water supply pressure	Bar	1÷8	1÷8	1÷8	1÷8	1÷8	1÷8
NET WEIGHT (2)	kg	6	6	10	10	10	10
HYDRAULIC CONNECTION							
WATER INLET - ISO 228/1 – G M	Ø	3/4"	3/4"	3/4"	3/4"	3/4"	3/4"
WATER OUTLET - external diameter	Ø mm	19	19	19	19	19	19

VERSION (1)		U / O	U / O	U / O	U / O	U / O	U / O
MODEL		039 P2 D	048 P2 D	055 P2 D	062 P2 D	075 P2 D	082 P2 D
SIZE		E5	E5	E6	E6	E7	E7
STEAM PRODUCTION	kg/h	8,0	8,0	8,0	8,0	8,0	8,0
Power input	kW	6,0	6,0	6,0	6,0	6,0	6,0
Absorbed current (OA)	A	8,7	8,7	8,7	8,7	8,7	8,7
Max absorbed current (FLA)	A	12,4	12,4	12,4	12,4	12,4	12,4
Water content	l	6,0	6,0	6,0	6,0	6,0	6,0
Max water supply pressure	Bar	1÷8	1÷8	1÷8	1÷8	1÷8	1÷8
NET WEIGHT (2)	kg	12	12	14	14	14	14
HYDRAULIC CONNECTION							
WATER INLET - ISO 228/1 – G M	Ø	3/4"	3/4"	3/4"	3/4"	3/4"	3/4"
WATER OUTLET - external diameter	Ø mm	19	19	19	19	19	19

VERSION (1)		U / O	U / O	U	U
MODEL		092 P2 D	102 P2 D	117 P4 D	146 P4 D
SIZE		E8	E8	E9	E9
STEAM PRODUCTION	kg/h	8,0	8,0	8,0	8,0
Power input	kW	6,0	6,0	6,0	6,0
Absorbed current (OA)	A	8,7	8,7	8,7	8,7
Max absorbed current (FLA)	A	12,4	12,4	12,4	12,4
Water content	l	6,0	6,0	6,0	6,0
Max water supply pressure	Bar	1÷8	1÷8	1÷8	1÷8
NET WEIGHT (2)	kg	14	14	14	14
HYDRAULIC CONNECTION					
WATER INLET - ISO 228/1 – G M	Ø	3/4"	3/4"	3/4"	3/4"
WATER OUTLET - external diameter	Ø mm	19	19	19	19

1. U = Under, downflow / O = Over, upflow
2. Value to be added to the weight of the standard unit. Does not include the weight of the water content.

EXTRA POWER HUMIDIFIERS

The optional is not available for size E0, E1.

The components are the same of the standard accessory

TECHNICAL DATA

VERSION (1)		U / O	U / O	U / O	U / O	U / O	U / O
MODEL		007 P1 S	009 P1 S	011 P1 S	014 P1 S	016 P1 S	020 P1 S
SIZE		E0	E0	E1	E2	E2	E3
STEAM PRODUCTION	kg/h	--	--	--	8	8	8
Power input	kW	--	--	--	6,0	6,0	6,0
Absorbed current (OA)	A	--	--	--	8,7	8,7	8,7
Max absorbed current (FLA)	A	--	--	--	12,4	12,4	12,4
Water content	l	--	--	--	6,4	6,4	6,4
Max water supply pressure	Bar	--	--	--	1÷8	1÷8	1÷8
NET WEIGHT (2)	kg	--	--	--	10	10	10
HYDRAULIC CONNECTION							
WATER INLET - ISO 228/1 – G M	Ø	--	--	--	3/4"	3/4"	3/4"
WATER OUTLET - external diameter	Ø mm	--	--	--	19	19	19

VERSION (1)		U / O	U / O	U / O	U / O	U / O	U / O
MODEL		022 P1 S	026 P1 S	032 P1 S	037 P1 S	041 P1 S	045 P1 S
SIZE		E3	E3	E4	E4	E4	E4
STEAM PRODUCTION	kg/h	8	8	15	15	15	15
Power input	kW	6,0	6,0	11,3	11,3	11,3	11,3
Absorbed current (OA)	A	8,7	8,7	16,2	16,2	16,2	16,2
Max absorbed current (FLA)	A	12,4	12,4	23	23	23	23
Water content	l	6,4	6,4	10,3	10,3	10,3	10,3
Max water supply pressure	Bar	1÷8	1÷8	1÷8	1÷8	1÷8	1÷8
NET WEIGHT (2)	kg	10	10	16	16	16	16
HYDRAULIC CONNECTION							
WATER INLET - ISO 228/1 – G M	Ø	3/4"	3/4"	3/4"	3/4"	3/4"	3/4"
WATER OUTLET - external diameter	Ø mm	19	19	19	19	19	19

VERSION (1)		U / O	U / O	U / O	U / O	U / O	U / O
MODEL		039 P2 D	048 P2 D	055 P2 D	062 P2 D	075 P2 D	082 P2 D
SIZE		E5	E5	E6	E6	E7	E7
STEAM PRODUCTION	kg/h	15	15	15	15	15	15
Power input	kW	11,3	11,3	11,3	11,3	11,3	11,3
Absorbed current (OA)	A	16,2	16,2	16,2	16,2	16,2	16,2
Max absorbed current (FLA)	A	23	23	23	23	23	23
Water content	l	10,3	10,3	10,3	10,3	10,3	10,3
Max water supply pressure	Bar	1÷8	1÷8	1÷8	1÷8	1÷8	1÷8
NET WEIGHT (2)	kg	16	16	16	16	16	16
HYDRAULIC CONNECTION							
WATER INLET - ISO 228/1 – G M	Ø	3/4"	3/4"	3/4"	3/4"	3/4"	3/4"
WATER OUTLET - external diameter	Ø mm	19	19	19	19	19	19

1. U = Under, downflow / O = Over, upflow
2. Value to be added to the weight of the standard unit. Does not include the weight of the water content

TECHNICAL DATA

VERSION (1)		U / O	U / O	U	U
MODEL		092 P2 D	102 P2 D	117 P4 D	146 P4 D
SIZE		E8	E8	E9	E9
STEAM PRODUCTION	kg/h	15	15	15	15
Power input	kW	11,3	11,3	11,3	11,3
Absorbed current (OA)	A	16,2	16,2	16,2	16,2
Max absorbed current (FLA)	A	23	23	23	23
Water content	l	10,3	10,3	10,3	10,3
Max water supply pressure	Bar	1÷8	1÷8	1÷8	1÷8
NET WEIGHT (2)	kg	16	16	16	16
HYDRAULIC CONNECTION					
WATER INLET - ISO 228/1 – G M	Ø	3/4"	3/4"	3/4"	3/4"
WATER OUTLET - external diameter	Ø mm	19	19	19	19

1. U = Under, downflow / O = Over, upflow
2. Value to be added to the weight of the standard unit. Does not include the weight of the water content.

OPTIONAL ACCESSORIES : P051 – DEHUMIDIFICATION FUNCTION

The optional requires mandatory accessory "P161 T/rH air intake sensor".

Components:

- T / rH air intake sensor.
- Electronic control system of the dew point temperature for the combined intervention of cooling capacity and air flow.

OPTIONAL ACCESSORIES: P161 - T/RH AIR INTAKE SENSOR

OPTIONAL ACCESSORIES: P071 - REMOTE T/RH PROBE



P161: T/RH AIR INTAKE SENSOR

The accessory replaces the temperature sensor installed on the air intake in the unit and allows the displaying of the relative humidity room value.

The sensor is mandatorily required with following option:

- 4301 / 4303 / 4305 Humidifier;
- P161 Dehumidification function;
- P034 Intake free-cooling plenum.
- P211 Hot gas heating+4way valve.

P071: REMOTE T/RH PROBE

The accessory is added to the standard temperature sensor or to the temperature / humidity sensor (optional) on the machine air intake. For indoor installation in a specific point of the room to be conditioned.

OPTIONAL ACCESSORIES: 4666 – EXTERNAL AIR PROBE



The probe must be installed protected against atmospheric agent and allows the displaying of the external air temperature.

The probe is mandatorily required with following option:

- P034 Intake free-cooling plenum.

OPTIONAL ACCESSORIES: P111 – DUAL POWER SUPPLY

OPTIONAL ACCESSORIES: P112 – DUAL POWER SUPPLY + OPTIONAL

OPTIONAL ACCESSORIES: P113 – KIT DUAL POWER SUPPLY

OPTIONAL ACCESSORIES: P114 – KIT DUAL POWER SUPPLY + OPTIONAL



The motorised changeover switches automatically manage changeover under load between two three-phase power supplies, or manually for emergency operations.

These devices are suitable for low voltage systems with interruption of the supply to the load during transfer.

The model supplied in the automatic version checks the source and switches over automatically, based on configurable parameters.

OPEN TRANSITION TYPE TRANSFER SWITCH WITH A MINIMUM INTERRUPTION OF THE SUPPLY DURING TRANSFER.

To maintain the microprocessor powered and avoid its restarts it is suggested the “P091 Back-up module controller” optional accessory. The back-up module guarantees the microprocessor power supply for a few minutes, in case of supply voltage failure.

The remote condenser must be powered by the automatic transfer switch.

It is suggested the optional “P191 power supply for condenser” from the indoor machine electrical board.

The optional includes magnetothermic switches for condenser fans.

INSTALLATION

Frame	Power Supply	Installation	Code
E0	400/3+N/50	EXTERNAL to the unit, supplied in kit	P113, P114 (*)
E1	400/3+N/50	EXTERNAL to the unit, supplied in kit	P113, P114 (*)
E2	400/3+N/50	EXTERNAL to the unit, supplied in kit	P113, P114 (*)
E3	400/3+N/50	EXTERNAL to the unit, supplied in kit	P113, P114 (*)
E4	400/3+N/50	EXTERNAL to the unit, supplied in kit	P113, P114 (*)
E5	400/3+N/50	INTERNAL (on unit electrical panel)	P111, P112 (*)
E6	400/3+N/50	INTERNAL (on unit electrical panel)	P111, P112 (*)
E7	400/3+N/50	INTERNAL (on unit electrical panel)	P111, P112 (*)
E8	400/3+N/50	INTERNAL (on unit electrical panel)	P111, P112 (*)
E9	400/3+N/50	INTERNAL (on unit electrical panel)	P111, P112 (*)

(*) P112, P114 for units with optional (with electric heaters and/or humidifier)

MOUNTING KIT

For EXTERNAL installation, the optional accessory is supplied in special box with IP 3X ingress protection, with the dimensions shown in the figure below.

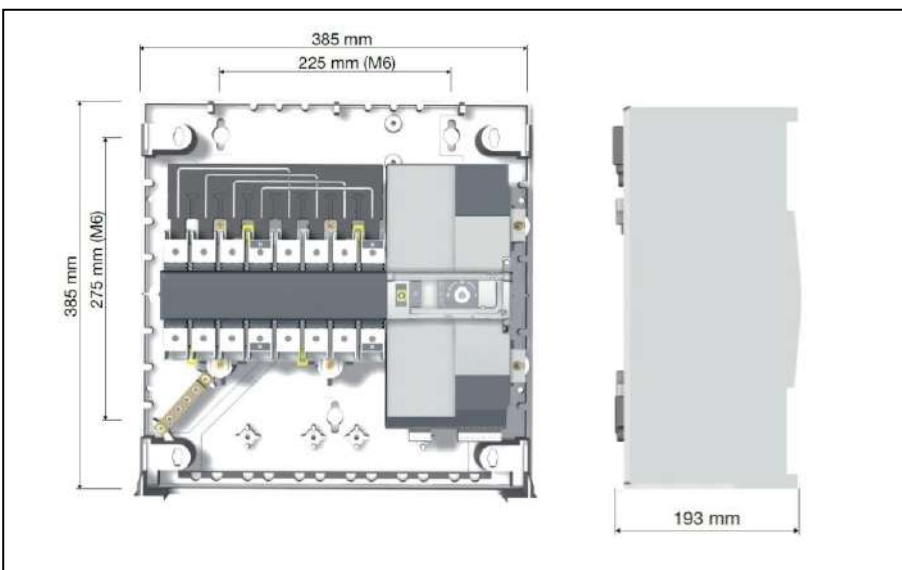

OPTIONAL ACCESSORIES: A381 - DRAIN PUMP



A plastic case contains the vertical type pump, the water tank with float plus safety switch and hydraulic and electric connection.

Together the pump 10 linear meters anti-crushing plastic discharge spiral tube is supplied. The optional must be installed as shown in the documentation delivered together with the unit.

Wiring includes power supply and an alarm, displayed on microprocessor, that includes motor pump thermal protection and tank overflow.

The condensate discharge pump operation is fully automatic.

WARNING

For all the machines the optional accessory is supplied in mounting kit.

TECHNICAL DATA

- Power supply: 230V~ 50Hz
- Electrical data: 70W – 0,67A
- Maximum water flow: 500 l/h
- Maximum delivery height: 5.0 m
- Sound level: 45dBA a 1 m
- Maximum water temperature: 70°C
- Water acidity: pH>2.5
- Tray volume: 2.0 l
- Protection IP 20

CONDENSATE DISCHARGE PUMP

(Dimensions in millimetres)

OPERATING DATA

Discharge head	Total length of discharge pipes (Ø 10 mm internal)			
	5m	10m	20m	30m
1m	380	300	240	190
2m	310	260	200	150
3m	240	200	145	110
4m	150	130	80	60
5m	30	20	0	0

OPTIONAL ACCESSORIES: P084 – AIR FILTER ePM₁₀ 50%

The optional is not available for size E0.
 The ePM₁₀ 50% air filters (according to ISO EN 16890), replace the standard one.
 The filters generate a pressure drops higher than the standard ones.
 The filters are made of glass micro-fibre and are not regenerable.

VERSION (1)		U / O	U / O	U / O	U / O	U / O	U / O
MODEL		007 P1 S	009 P1 S	011 P1 S	014 P1 S	016 P1 S	020 P1 S
SIZE		E0	E0	E1	E2	E2	E3
Additional pressure drops (2)	Pa	-	-	53	65	70	54

VERSION (1)		U / O	U / O	U / O	U / O	U / O	U / O
MODEL		022 P1 S	026 P1 S	032 P1 S	037 P1 S	041 P1 S	045 P1 S
SIZE		E3	E3	E4	E4	E4	E4
Additional pressure drops (2)	Pa	62	68	30	39	45	45

VERSION (1)		U / O	U / O	U / O	U / O	U / O	U / O
MODEL		039 P2 D	048 P2 D	055 P2 D	062 P2 D	075 P2 D	082 P2 D
SIZE		E5	E5	E6	E6	E7	E7
Additional pressure drops (2)	Pa	23	35	41	44	72	72

VERSION (1)		U / O	U / O	U	U
MODEL		092 P2 D	102 P2 D	117 P4 D	146 P4 D
SIZE		E8	E8	E9	E9
Additional pressure drops (2)	Pa	69	69	94	94

1. U = Under, downflow / O = Over, upflow
2. Additional pressure drops referred to nominal air flow and clean filter.

OPTIONAL ACCESSORIES: A531 – ON-OFF DAMPER

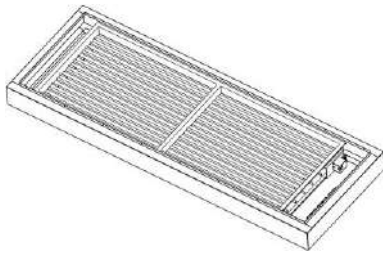

The optional is not available for size E0.
 Non-return air damper with frame driven by electric servomotor.
 Accessory installed on units air delivery and it can be matched to plenums and support frame.
 The accessory requires mandatory accessory "9973 Wooden cage packing".

FRAMEWORK

- Frame in galvanized steel sheet with protective surfaces treatment in compliance with UNI ISO 9227/ASTMB117 and ISO 7253, and painted with epoxy powders. Colour RAL 9005;
- Opposed blade dampers in galvanized steel sheet.
- Actuator for damper control.
- Terminals for electric connection to the unit.

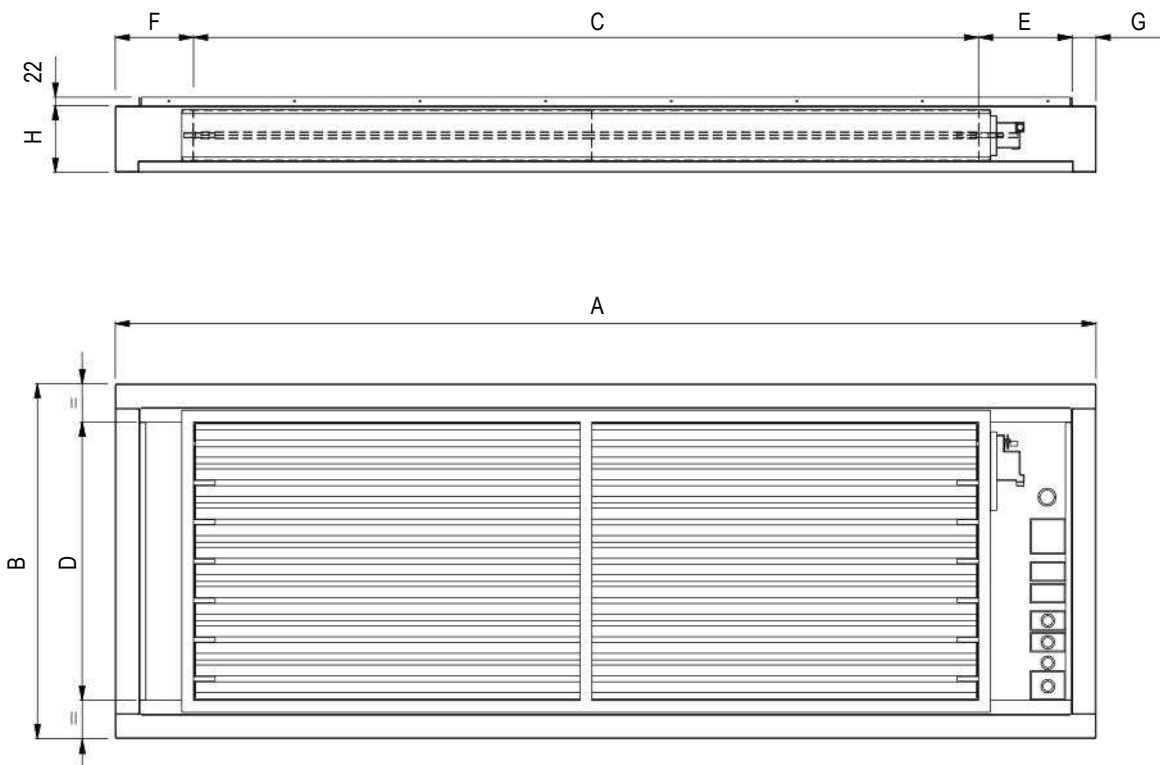

VERSION (1)		U/O	U/O	U/O	U/O	U/O	U/O	U/O	U/O	U/O	U
SIZE		E0	E1	E2	E3	E4	E5	E6	E7	E8	E9
A	mm	-	650	785	1085	1305	1630	1873	2175	2499	2899
B	mm	-	650	650	750	905	905	905	905	905	905
C	mm	-	300	450	750	900	1250	1500	1750	2000	2300
D	mm	-	510	510	610	710	710	710	710	710	710
E	mm	-	231	216	216	142	204	250,5	226,5	238,5	288,5
F	mm	-	73	73	73	202	115	61,5	137,5	199,5	249,5
G	mm	-	46	46	46	61	61	61	61	61	61
H	mm	-	170	170	170	170	170	170	170	170	170
Weight (2)	kg	-	20	23	30	40	50	58	65	75	90

1. U = Under, downflow / O = Over, upflow
 2. Add this value to the total unit weight

INSTALLATION EXAMPLE

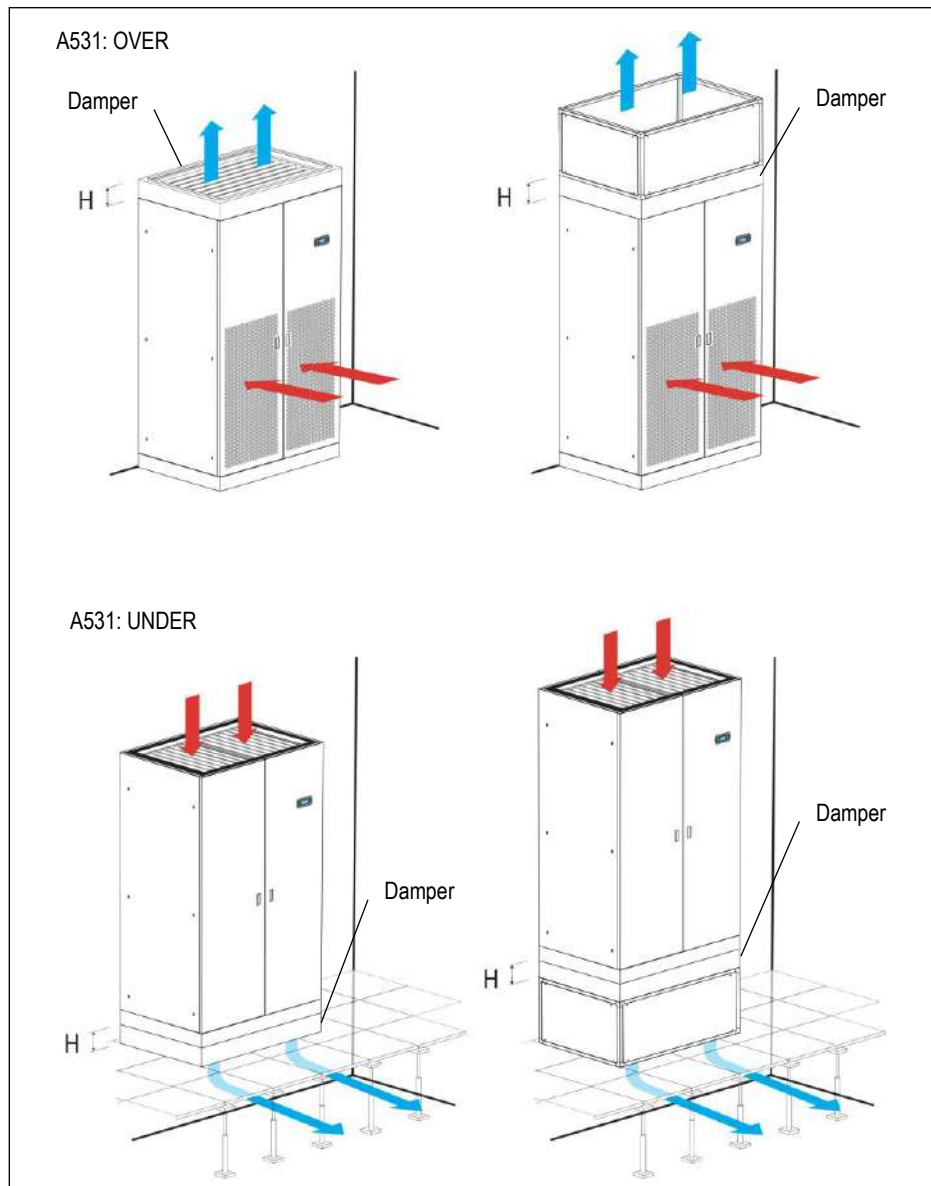

WORKING LOGIC

The damper opens at supply fans activation to allow air flow.

When the fans stop for failure or stop command, the damper closes, preventing air flow into the unit.

OPTIONAL ACCESSORIES: P011 - EMPTY PLENUM

OPTIONAL ACCESSORIES: P012 - EMPTY PLENUM CL.A1

OPTIONAL ACCESSORIES: P031 - EMPTY INTAKE PLENUM

OPTIONAL ACCESSORIES: P032 - EMPTY INTAKE PLENUM CL.A1

OPTIONAL ACCESSORIES: P013 - PLENUM + 3 GRILLES

OPTIONAL ACCESSORIES: P014 - PLENUM + 3 GRILLES CL.A1

OPTIONAL ACCESSORIES: P015 - SILENCED PLENUM

OPTIONAL ACCESSORIES: P016 - SILENCED PLENUM + 1 GRILLE

OPTIONAL ACCESSORIES: P017 - PLENUM + FILTER EPM2.5 50%

OPTIONAL ACCESSORIES: P018 - PLENUM + FILTER EPM1 50%

OPTIONAL ACCESSORIES: P019 - PLENUM + FILTER EPM1 85%

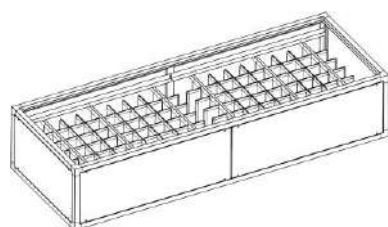
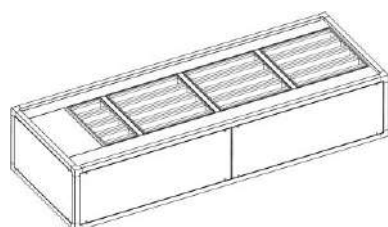
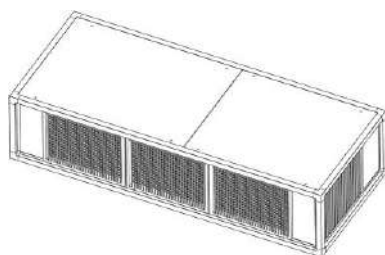
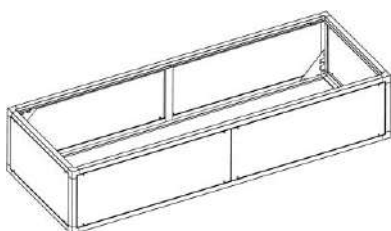

The optional is supplied separately and the installation on the unit is at Customer care.
The plenums have same technical characteristics and base dimensions of the machine cabinet.

It is possible to install only a single plenum to ensure stability to the unit.

FRAMEWORK

- Frame in aluminium extrusion, painted with epoxy powders. Colour RAL 9005;
- Panels in galvanized steel sheet with protective surfaces treatment in compliance with UNI ISO 9227/ASTMB117 and ISO 7253, and painted with epoxy powders. Colour RAL 9005;
- Panels insulated with polyurethane foam and seals to ensure air tight.
- Panels fixed with screws.
- Removable panels.
- Set of fixing elements to fasten the plenum to the unit.

WARNING

In UNDER version units the piping is inside the machine.

The air delivery plenums sometime don't allow the extension of the pipes downwards.

In special cases, to keep the connections inside the machine, foresee a plenum 200mm higher than the standard one.

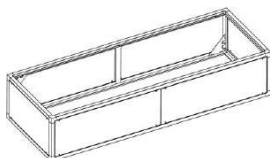

P011 / P012 – P031 / P032: EMPTY PLENUM

The optional is not available for size E0.

The plenum is void and can be used to rise the intake/delivery air inlet/outlet.

Remove the frontal panels for inspection.

Also available with fire reaction in class “0” or “A1” (EN 13501-1).

The optional accessories “P031 Empty intake plenum, for OVER version” and “P032 Empty intake plenum CL.A1, for OVER version” require mandatory accessory “P122 Bottom air intake+blind panels, for OVER version only”.

P011 / P012 OVER

P031 / P032 OVER

P011 / P012 UNDER

P031 / P032 UNDER

VERSION (1)		U / O	U / O	U / O	U / O	U / O	U / O	U / O	U / O	U / O	U
SIZE		E0	E1	E2	E3	E4	E5	E6	E7	E8	E9
A	mm	-	490	490	490	510	510	510	510	510	510
Weight (2)	kg	-	20	21	20	30	40	45	50	60	70
Weight CL.0 or A1 (EN 13501-1) (2)	kg	-	25	27	27	39	50	56	62	74	85

1. U = Under, downflow / O = Over, upflow
2. Add this value to the total unit weight

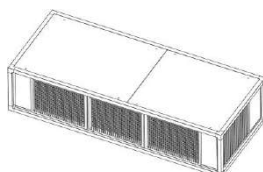

P013 / P014: PLENUM + 3 GRILLES

The plenum must be installed on air delivery.

The plenum allows the air distribution directly into the room. The plenum is supplied with air distribution grilles with double row adjustable grilles on front and lateral side.

Also available with fire reaction in class “0” or “A1” (EN 13501-1).

P013 / P014 OVER

P013 / P014 UNDER

VERSION (1)		U / O	U / O	U / O	U / O	U / O	U / O	U / O	U / O	U / O	U
SIZE		E0	E1	E2	E3	E4	E5	E6	E7	E8	E9
A	mm	490	490	490	490	510	510	510	510	510	510
Weight (2)	kg	15	21	23	30	45	50	65	75	90	100
Weight CL.0 or A1 (EN 13501-1) (2)	kg	18	25	28	37	54	61	77	89	106	118

1. U = Under, downflow / O = Over, upflow
2. Add this value to the total unit weight

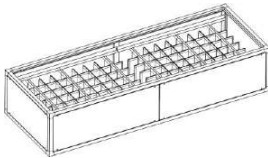

P015: SILENCED PLENUM

The optional is not available for size E0.

The plenum must be installed on air delivery.

The plenum is fitted with noise absorption partitions to reduce the noise emission.

Remove the frontal panels for inspection.

P015 OVER

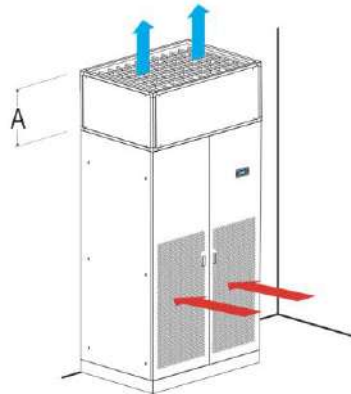

P015 UNDER

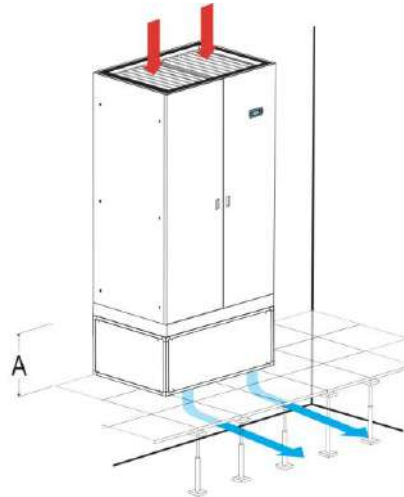

VERSION (1)		U / O	U / O	U / O	U / O	U / O	U / O	U / O	U / O	U	
SIZE		E0	E1	E2	E3	E4	E5	E6	E7	E8	E9
A	mm	-	490	490	490	510	510	510	510	510	510
Weight (2)	kg	-	25	27	30	45	50	65	80	90	100

1. U = Under, downflow / O = Over, upflow
2. Add this value to the total unit weight

ACOUSTIC DATA

VERSION (1)		U / O	U / O	U / O	U / O	U / O	
MODEL		007 P1 S	009 P1 S	011 P1 S	014 P1 S	016 P1 S	020 P1 S
SIZE		E0	E0	E1	E2	E2	E3
SOUND LEVEL ISO 3744 (2)							
On air delivery, Under	dB(A)	--	--	60,4	66,7	67,8	66,4
On air intake, Under	dB(A)	--	--	56,1	57,4	58,5	57,3
On front side, Under	dB(A)	--	--	46,9	48	49,1	47,9
On air delivery, Over	dB(A)	--	--	60,4	66,7	67,8	66,4
On air intake, Over (3)	dB(A)	--	--	51,7	54,1	55,5	55,4
On front side, Over (4)	dB(A)	--	--	42,0	47,6	48,6	47,0
Air flow (5)	m ³ /h	--	--	2800	4000	4200	5700

VERSION (1)		U / O	U / O	U / O	U / O	U / O	U / O
MODEL		022 P1 S	026 P1 S	032 P1 S	037 P1 S	041 P1 S	045 P1 S
SIZE		E3	E3	E4	E4	E4	E4
SOUND LEVEL ISO 3744 (2)							
On air delivery, Under	dB(A)	67,9	68,9	73,8	76,8	74,6	74,6
On air intake, Under	dB(A)	59,2	59,5	64,1	67,0	66,4	66,4
On front side, Under	dB(A)	49,9	50,1	54,6	57,5	57,0	57,0
On air delivery, Over	dB(A)	67,9	68,9	73,8	76,8	74,6	74,6
On air intake, Over (3)	dB(A)	58,6	57,0	60,5	62,6	62,4	62,4
On front side, Over (4)	dB(A)	48,9	49,4	54,3	57,3	56,7	56,7
Air flow (5)	m ³ /h	6100	6400	8700	10000	10800	10800

1. U = Under, downflow / O = Over, upflow
2. Noise pressure level at 1 meter in free field – ISO 3744
3. Air intake from the front
4. Air intake from the bottom
5. Nominal air flow with noise absorption partitions plenum installation and external static pressure 20 Pa.

ACOUSTIC DATA

VERSION (1)		U / O	U / O	U / O	U / O	U / O	U / O
MODEL		039 P2 D	048 P2 D	055 P2 D	062 P2 D	075 P2 D	082 P2 D
SIZE		E5	E5	E6	E6	E7	E7
SOUND LEVEL ISO 3744 (2)							
On air delivery, Under	dB(A)	77,0	77,1	73,7	74,6	75,9	75,9
On air intake, Under	dB(A)	67,2	68,9	64,2	65,1	67,7	67,7
On front side, Under	dB(A)	57,7	59,4	54,7	55,7	58,4	58,4
On air delivery, Over	dB(A)	77,0	77,1	73,7	74,6	75,9	75,9
On air intake, Over (3)	dB(A)	62,7	64,3	60,9	62,3	63,9	63,9
On front side, Over (4)	dB(A)	57,5	59,3	54,2	55,1	58,0	58,0
Air flow (5)	m ³ /h	10000	12000	15000	15600	20000	20000

VERSION (1)		U / O	U / O	U	U
MODEL		092 P2 D	102 P2 D	117 P4 D	146 P4 D
SIZE		E8	E8	E9	E9
SOUND LEVEL ISO 3744 (2)					
On air delivery, Under	dB(A)	78,1	78,1	79,1	79,1
On air intake, Under	dB(A)	69,9	69,9	70,9	70,9
On front side, Under	dB(A)	60,6	60,6	61,4	61,4
On air delivery, Over	dB(A)	78,1	78,1	-	-
On air intake, Over (3)	dB(A)	66,1	66,1	-	-
On front side, Over (4)	dB(A)	60,3	60,3	-	-
Air flow (5)	m ³ /h	22000	22000	32000	32000

1. U = Under, downflow / O = Over, upflow
2. Noise pressure level at 1 meter in free field – ISO 3744
3. Air intake from the front
4. Air intake from the bottom
5. Nominal air flow with noise absorption partitions plenum installation and external static pressure 20 Pa.

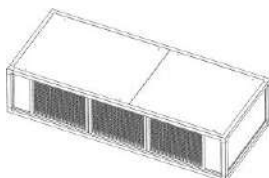

P016: SILENCED PLENUM + 1 GRILLE

The optional is not available for size E0.

The plenum must be installed on air delivery.

The plenum allows the frontal air distribution directly into the room and a noise reduction of the air delivery. The plenum is supplied with air distribution grille with double row adjustable grilles on front side and noise absorption partitions,

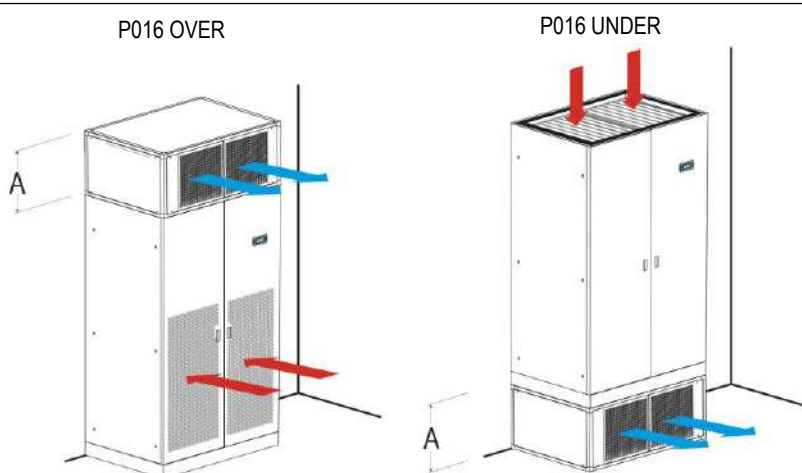

VERSION (1)		U / O	U / O	U / O	U / O	U / O	U / O	U / O	U / O	U	
SIZE		E0	E1	E2	E3	E4	E5	E6	E7	E8	E9
A	mm	-	490	490	490	510	510	510	510	510	510
Weight (2)	kg	-	30	30	37	67	72	78	88	110	130

1. U = Under, downflow / O = Over, upflow
2. Add this value to the total unit weight

ACOUSTIC DATA

VERSION (1)		U / O	U / O	U / O	U / O	U / O	U / O
MODEL		007 P1 S	009 P1 S	011 P1 S	014 P1 S	016 P1 S	020 P1 S
SIZE		E0	E0	E1	E2	E2	E3
SOUND LEVEL ISO 3744 (2)							
On air delivery, Under	dB(A)	--	--	60,0	67,3	68,3	66,3
On air intake, Under	dB(A)	--	--	55,8	58,1	59,2	57,7
On front side, Under	dB(A)	--	--	46,6	48,7	49,8	48,3
On air delivery, Over	dB(A)	--	--	60,0	67,3	68,3	66,3
On air intake, Over (3)	dB(A)	--	--	51,6	53,8	55,2	55,3
On front side, Over (4)	dB(A)	--	--	41,8	47,1	48,1	46,7
ADDITIONAL PRESSURE DROPS (5)	Pa	--	--	77	79	87	63
AIR FLOW	m ³ /h	--	--	2700	4000	4200	5700

VERSION (1)		U / O	U / O	U / O	U / O	U / O	U / O
MODEL		022 P1 S	026 P1 S	032 P1 S	037 P1 S	041 P1 S	045 P1 S
SIZE		E3	E3	E4	E4	E4	E4
SOUND LEVEL ISO 3744 (2)							
On air delivery, Under	dB(A)	67,7	68,7	73,1	76,1	73,9	73,9
On air intake, Under	dB(A)	59,6	60,0	64,1	67,0	66,4	66,4
On front side, Under	dB(A)	50,3	50,5	54,6	57,4	57,0	57,0
On air delivery, Over	dB(A)	67,7	68,7	73,1	76,1	73,9	73,9
On air intake, Over (3)	dB(A)	58,5	56,9	60,5	62,6	62,4	62,1
On front side, Over (4)	dB(A)	48,7	49,0	54,3	57,3	56,8	56,8
ADDITIONAL PRESSURE DROPS (5)	Pa	72	79	69	92	106	106
AIR FLOW	m ³ /h	6100	6400	8700	10000	10800	10800

VERSION (1)		U / O	U / O	U / O	U / O	U / O	U / O
MODEL		039 P2 D	048 P2 D	055 P2 D	062 P2 D	075 P2 D	082 P2 D
SIZE		E5	E5	E6	E6	E7	E7
SOUND LEVEL ISO 3744 (2)							
On air delivery, Under	dB(A)	76,2	76,4	73,3	74,1	75,3	75,3
On air intake, Under	dB(A)	67,1	68,7	64,4	65,3	67,8	67,9
On front side, Under	dB(A)	57,6	59,3	54,9	55,9	58,4	58,5
On air delivery, Over	dB(A)	76,2	76,4	73,3	74,1	75,3	75,3
On air intake, Over (3)	dB(A)	62,8	64,4	60,8	62,2	63,9	64,3
On front side, Over (4)	dB(A)	57,6	59,4	54,1	55,0	58,1	58,1
ADDITIONAL PRESSURE DROPS (5)	Pa	57	85	100	108	133	133
AIR FLOW	m ³ /h	10000	12000	15000	15600	20000	20000

VERSION (1)		U / O	U / O	U	U
MODEL		092 P2 D	102 P2 D	117 P4 D	146 P4 D
SIZE		E8	E8	E9	E9
SOUND LEVEL ISO 3744 (2)					
On air delivery, Under	dB(A)	77,3	77,3	78,5	78,5
On air intake, Under	dB(A)	69,8	69,9	70,9	70,9
On front side, Under	dB(A)	60,4	60,5	61,5	61,5
On air delivery, Over	dB(A)	77,3	77,3	--	--
On air intake, Over (3)	dB(A)	66,2	66,5	--	--
On front side, Over (4)	dB(A)	60,4	60,4	--	--
ADDITIONAL PRESSURE DROPS (5)	Pa	121	121	191	191
AIR FLOW	m ³ /h	22000	22000	32000	32000

1. U = Under, downflow / O = Over, upflow
2. Noise pressure level at 1 meter in free field – ISO 3744
3. Air intake from the front
4. Air intake from the bottom
5. Value to be subtracted from the nominal external static pressure of the unit

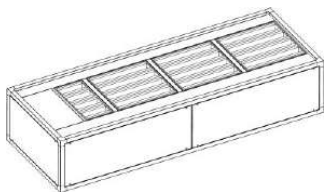

P017 / P018 / P019: SUPPLY PLENUM + FILTER

The optional is not available for size E0.
 The plenum must be installed on air delivery.
 The optional is not compatible with "P084 Air filter ePM10 50%".
 The plenum is fitted with high efficiency rigid bag filters.
 Filters are made of glass micro fibre and are not regenerable.
 Remove the frontal panels for filters replacement.

P017 / P018 / P019 OVER

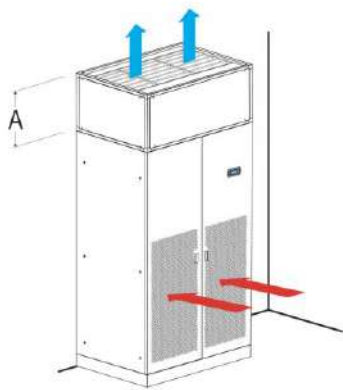

P017 / P018 / P019 UNDER

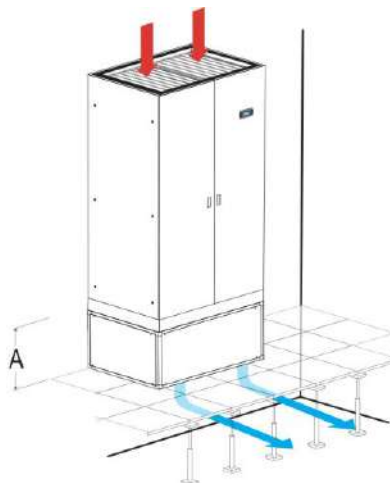

VERSION (1)		U / O	U / O	U / O	U / O	U / O	U / O	U / O	U / O	U	
SIZE		E0	E1	E2	E3	E4	E5	E6	E7	E8	E9
A	mm	-	490	490	490	510	510	510	510	510	510
Weight (2)	kg	-	26	27	30	45	55	65	80	90	100

1. U = Under, downflow / O = Over, upflow
2. Add this value to the total unit weight

VERSION (1)		U / O	U / O	U / O	U / O	U / O	
MODEL		007 P1 S	009 P1 S	011 P1 S	014 P1 S	016 P1 S	020 P1 S
SIZE		E0	E0	E1	E2	E2	E3
PRESSURE DROPS (2)							
Filters ePM _{2.5} 50%	Pa	-	-	85	89	97	82
Filters ePM ₁ 50%	Pa	-	-	98	129	138	120
Filters ePM ₁ 85%	Pa	-	-	115	151	165	141

VERSION (1)		U / O	U / O	U / O	U / O	U / O	
MODEL		022 P1 S	026 P1 S	032 P1 S	037 P1 S	041 P1 S	045 P1 S
SIZE		E3	E3	E4	E4	E4	E4
PRESSURE DROPS (2)							
Filters ePM _{2.5} 50%	Pa	94	102	60	80	93	93
Filters ePM ₁ 50%	Pa	134	145	94	118	133	133
Filters ePM ₁ 85%	Pa	158	173	110	139	158	158

1. U = Under, downflow / O = Over, upflow
2. Data referred to the nominal air flow and clean filters. Value to be subtracted from the nominal external static pressure of the unit.

VERSION (1)		U / O	U / O	U / O	U / O	U / O	U / O
MODEL		039 P2 D	048 P2 D	055 P2 D	062 P2 D	075 P2 D	082 P2 D
SIZE		E5	E5	E6	E6	E7	E7
PRESSURE DROPS (2)							
Filters ePM _{2.5} 50%	Pa	55	82	104	112	111	111
Filters ePM ₁ 50%	Pa	88	121	147	158	157	157
Filters ePM ₁ 85%	Pa	103	142	175	187	186	186

VERSION (1)		U / O	U / O	U	U
MODEL		092 P2 D	102 P2 D	117 P4 D	146 P4 D
SIZE		E8	E8	E9	E9
PRESSURE DROPS (2)					
Filters ePM _{2.5} 50%	Pa	117	117	192	192
Filters ePM ₁ 50%	Pa	139	139	230	231
Filters ePM ₁ 85%	Pa	164	164	275	275

1. U = Under, downflow / O = Over, upflow
2. Data referred to the nominal air flow and clean filters. Value to be subtracted from the nominal external static pressure of the unit.

OPTIONAL ACCESSORIES: P034 – INTAKE FREE-COOLING PLENUM

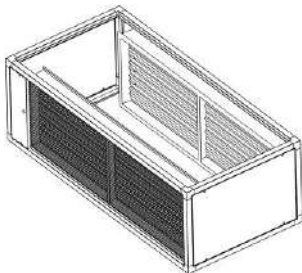
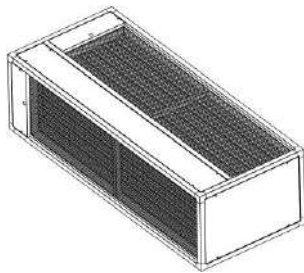

The optional is supplied separately and the installation on the unit is at Customer care.

The optional is not available for size E0.

The optional requires mandatory accessories “P161 T/rH air intake sensor”, “4666 External air probe”, “A812 Free-cooling direct control” and “P122 Bottom air intake+blind panels, for OVER version only”.

The plenums have same technical characteristics and base dimensions of the machine cabinet.

The optional allow to obtain free-cooling by direct ambient air intake into the room.

The dampers are proportionally managed by the microprocessor control, that regulates the quantity of the ambient air to put in the room per the set-point.

COMPONENTS

- Frame in aluminium extrusion, painted with epoxy powders. Colour RAL 9005;
- Panels in galvanized steel sheet with protective surfaces treatment in compliance with UNI ISO 9227/ASTMB117 and ISO 7253, and painted with epoxy powders. Colour RAL 9005;
- Panels insulated with polyurethane foam and seals to ensure air tight.
- Removable panels with screws.
- Opposed blade dampers in galvanized steel sheet and safety grille for ambient air and room air suction.
- Actuator for each damper.
- Terminals for electric connection to the unit.
- Set of fixing elements to fasten the plenum to the unit.
- T / rH air intake sensor. The sensor must be moved outside the air conditioners for a proper read of the room temperature value.
- External air probe. The sensor must be installed in the outdoor air suction duct or anyway protected against atmospheric agent.
- Free contact for free-cooling operating status monitoring.
- Terminals on indoor unit for:
 - 24 Vac power supply for the overpressure damper servomotor
 - 0-10Vdc control signal for the servomotor

INSTALLATION EXAMPLE

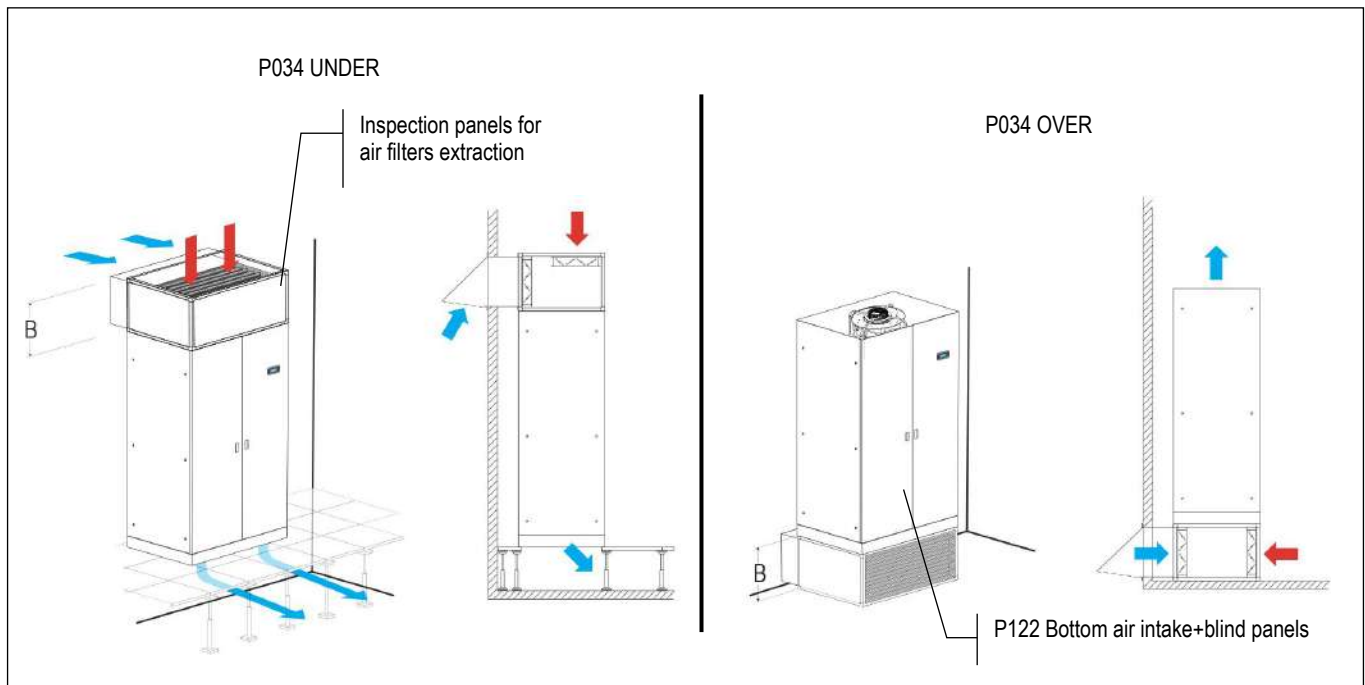

Ducting for ambient air suction are at Customer care.

A rain cover with grille on ambient air intake is recommended.

OVER VERSION

SIZE E1 / E2 / E3

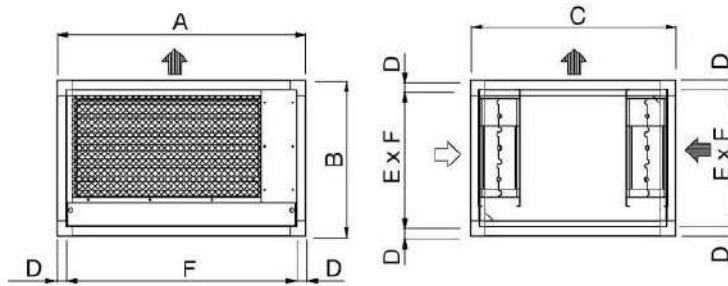

SIZE E4 / E5

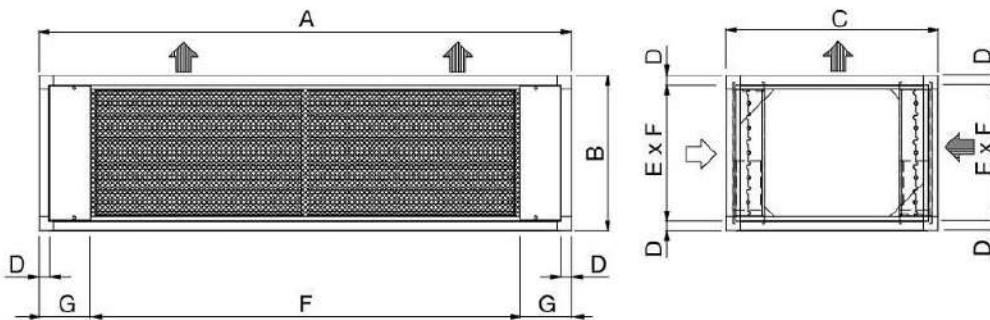

SIZE E6 / E7 / E8

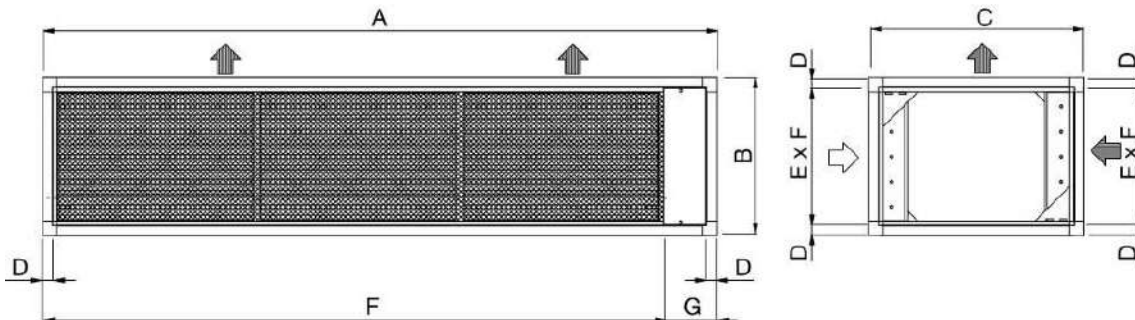

VERSION (1)		O	O	O	O	O	O	O	O	O	O
SIZE		E0	E1	E2	E3	E4	E5	E6	E7	E8	E9
A	mm	--	650	785	1085	1305	1630	1873	2175	2499	--
B	mm	--	490	490	490	630	630	630	630	630	--
C	mm	--	650	650	750	905	905	905	905	905	--
D	mm	--	30	30	30	40	40	40	40	40	--
E	mm	--	430	430	430	550	550	550	550	550	--
F	mm	--	590	725	1025	1035	1335	1664	1965	2220	--
G	mm	--	--	--	--	135	147,5	209	210	279	--
Weight (2)	kg	--	24	27	35	53	61	78	90	110	--

1. U = Under, downflow / O = Over, upflow
2. Add this value to the total unit weight

UNDER VERSION

SIZE E1 / E2 / E3

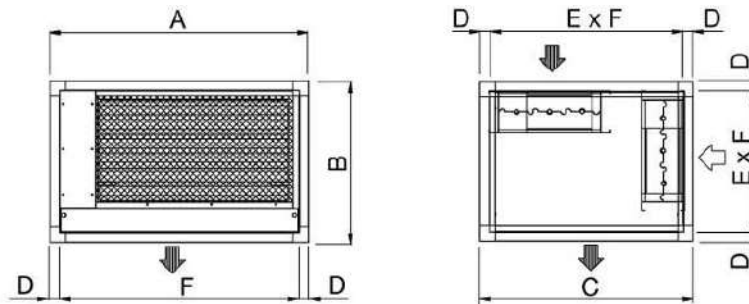

SIZE E4 / E5

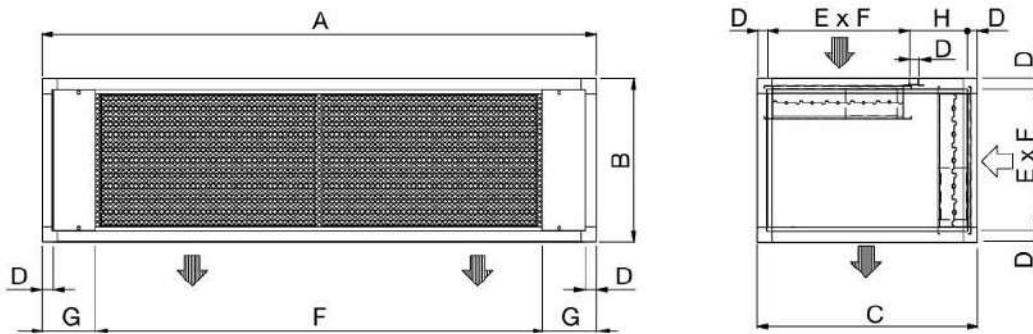

SIZE E6 / E7 / E8 / E9

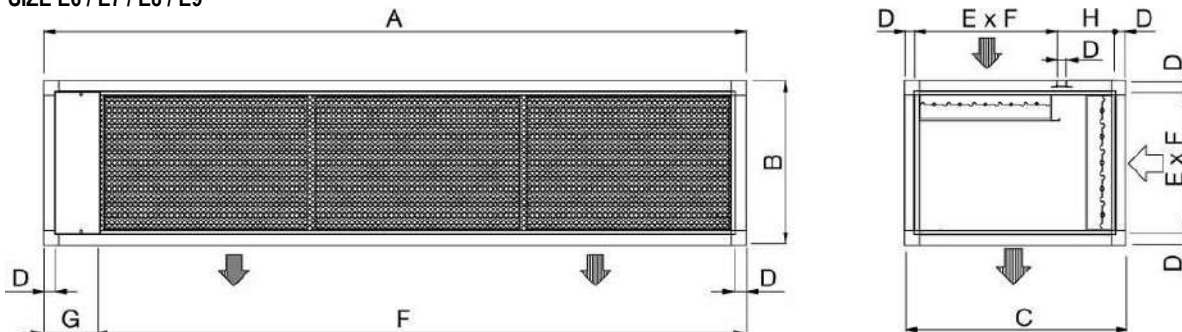

VERSION (1)		U	U	U	U	U	U	U	U	U	
SIZE		E0	E1	E2	E3	E4	E5	E6	E7	E8	E9
A	mm	--	650	785	1085	1305	1630	1873	2175	2499	2899
B	mm	--	490	490	490	630	630	630	630	630	630
C	mm	--	650	650	750	905	905	905	905	905	905
D	mm	--	30	30	30	40	40	40	40	40	40
E	mm	--	430	430	430	550	550	550	550	550	550
F	mm	--	590	725	1025	1035	1335	1664	1965	2220	2670
G	mm	--	--	--	--	135	147,5	209	210	279	229
H	mm	--	--	--	--	275	275	275	275	275	275
Weight (2)	kg		24	27	35	53	61	78	90	110	130

1. U = Under, downflow / O = Over, upflow
2. Add this value to the total unit weight

WARNING

IT IS COMPULSORY TO INSTALL INTO THE ROOM AN APPROPRIATELY SIZED OVERPRESSURE DAMPER TO ALLOW THE ROOM AIR EXHAUSTION DURING FREE-COOLING WORKING MODE

OVERPRESSURE DAMPER – Not supplied

During free-cooling operation, the air conditioner supplies ambient air directly into the room, this causes an increase in air pressure inside the room.

The overpressure damper avoids the increase in pressure in the room.

The damper must be installed at the highest point of the room to expel excess hot air to the outside.

Install the damper if possible in opposite position to air conditioner.

Air exhaustion must be protected with a rain cover and a grille (at Customer care).

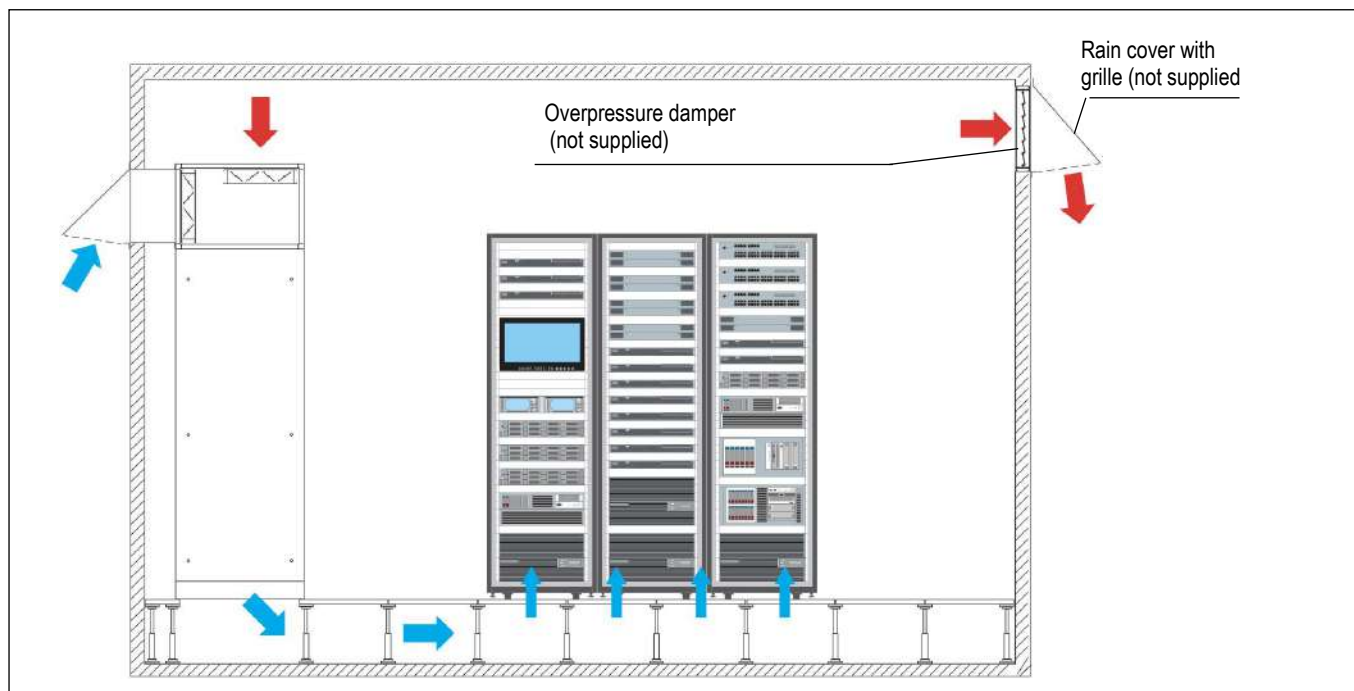

OPTIONAL ACCESSORIES: P041 – SUPPORT FRAME H 255-350MM

OPTIONAL ACCESSORIES: P042 – SUPPORT FRAME H 355-450MM

OPTIONAL ACCESSORIES: P043 – SUPPORT FRAME H 400-510MM

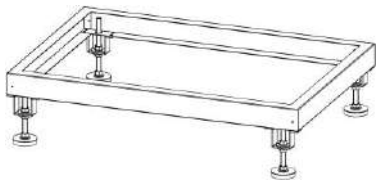

The accessory is supplied as an assembly kit.
It is not possible to match the support frame with plenum installed under the machine.
The floor stand is available in 3 different heights.

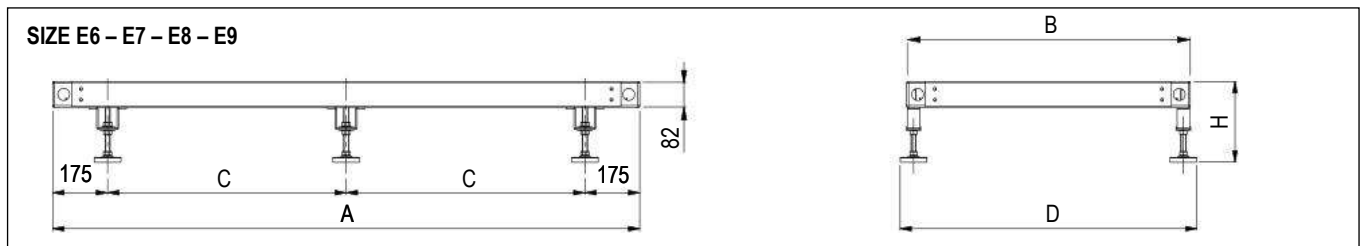
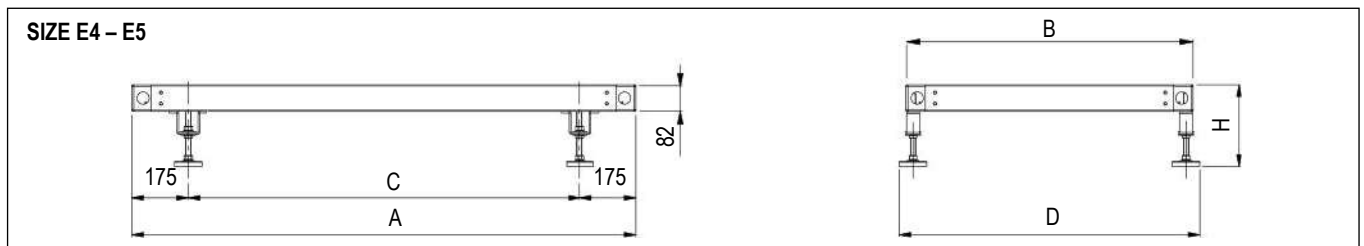
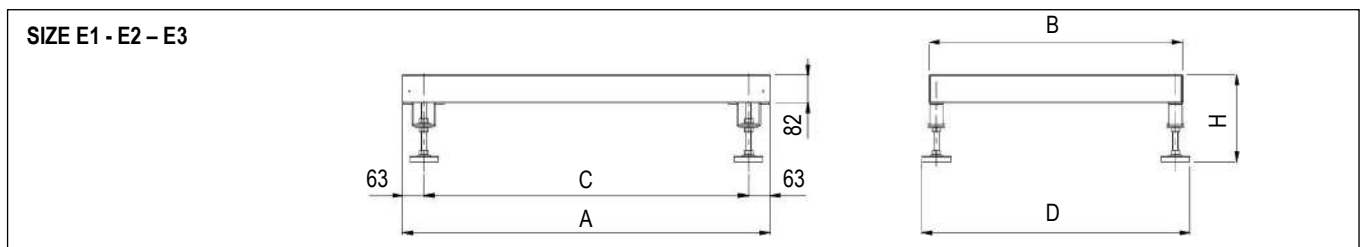
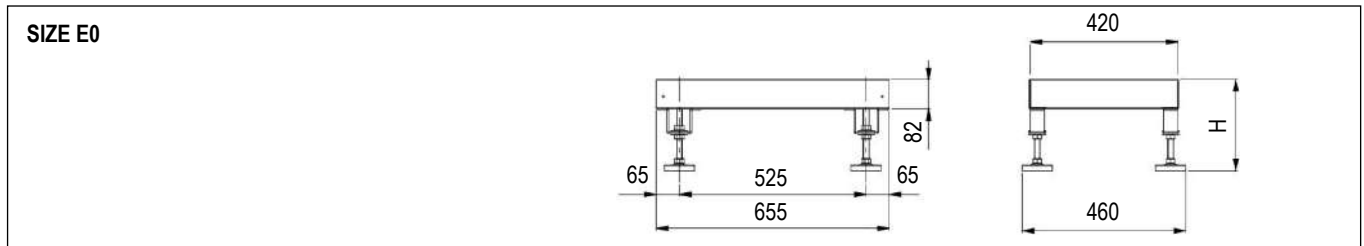

SIZE		E0	E1	E2	E3	E4	E5	E6	E7	E8	E9
A	mm	655	650	785	1085	1305	1630	1873	2175	2499	2899
B	mm	420	650	650	750	905	905	905	905	905	905
C	mm	525	524	659	959	955	1280	761,5	912,5	1074,5	1274,5
D	mm	460	691	691	791	945	945	945	945	945	945

MODEL		P041 - Hmax350	P042 - Hmax450	P043 - Hmax510
H min height	mm	255	355	400
H max height	mm	350	450	510

OPTIONAL ACCESSORIES: 3601 – COMPRESSOR OPERATING SIGNAL CONTACT

A voltage free electrical contact is supplied for remote signalling "Compressor operation".
Electrical connection on the machine's terminal board.

OPTIONAL ACCESSORIES: 2411 – PHASE SEQUENCE RELAY



The system checks that the phase sequence of the power supply is correct to prevent the opposite rotation of the three phase electric motors of the machine as compressors. The optional is installed in the electrical box downstream the main switch with door lock safety and in case of wrong phase sequence prevents starting the machine.

OPTIONAL ACCESSORIES: 1511 – SOFT STARTER



The optional is not available for size E0, E1, E2. Compressor motors soft-starter system. The system is contained in the electrical box. Its function is to reduce the starting current of the motor with a monitored start.

The optional temporarily reduces the load in the power circuit and starting current of the motor during start-up. This reduces the mechanical stress and torque on the motor and mechanical parts, as well as the electrodynamic stresses on the power cables and electrical distribution network, extending the lifespan of the system.

VERSION (1)		U / O	U / O	U / O	U / O	U / O	U / O
MODEL		007 P1 S	009 P1 S	011 P1 S	014 P1 S	016 P1 S	020 P1 S
SIZE		E0	E0	E1	E2	E2	E3
ON/OFF COMPRESSORS		-	-	-	-	-	scroll
Compressors number	#	-	-	-	-	-	1
Total starting current [LRA]	A	-	-	-	-	-	64
WITH SOFT STARTER							
Total starting current [LRA]	A	-	-	-	-	-	37

VERSION (1)		U / O	U / O	U / O	U / O	U / O	U / O
MODEL		022 P1 S	026 P1 S	032 P1 S	037 P1 S	041 P1 S	045 P1 S
SIZE		E3	E3	E4	E4	E4	E4
ON/OFF COMPRESSORS		scroll	scroll	scroll	scroll	scroll	scroll
Compressors number	#	1	1	1	1	1	1
Total starting current [LRA]	A	75	101	128	139	118	140
WITH SOFT STARTER							
Total starting current [LRA]	A	47	51	57	67	79	97

VERSION (1)		U / O	U / O	U / O	U / O	U / O	U / O
MODEL		039 P2 D	048 P2 D	055 P2 D	062 P2 D	075 P2 D	082 P2 D
SIZE		E5	E5	E6	E6	E7	E7
ON/OFF COMPRESSORS		scroll	scroll	scroll	scroll	scroll	scroll
Compressors number	#	2	2	2	2	2	2
Total starting current [LRA]	A	76	90	117	146	161	143
WITH SOFT STARTER							
Total starting current [LRA]	A	50	63	69	78	94	107

VERSION (1)		U / O	U / O	U	U
MODEL		092 P2 D	102 P2 D	117 P4 D	146 P4 D
SIZE		E8	E8	E9	E9
ON/OFF COMPRESSORS		scroll	scroll	scroll	scroll
Compressors number	#	2	2	4	4
Total starting current [LRA]	A	171	208	183	193
WITH SOFT STARTER					
Total starting current [LRA]	A	131	143	131	150

1. U = Under, downflow / O = Over, upflow

OPTIONAL ACCESSORIES: 3301 – COMPRESSOR REPHASING

Compressors capacitor for power factor - $\cos\phi$ 0,9 (sizes E1, E2 excluded).

OPTIONAL ACCESSORIES: A181 – COMPRESSOR SOUNDPROOF JACKET



A soundproof jacket for each compressor to obtain a reduction of 2dB(A) of the sound level of the unit.

OPTIONAL ACCESSORIES: A272 – CL.0 or A1 (EN13501-1) INSULATION

The optional is designed **TO SUPPLY THE PANELING ONLY WITH FIRE REACTION IN CLASS “0” OR “A1 (EN 13501-1)”**; furthermore, allows a noise insulation of the panels of the air conditioners. The pressure level reduction of the unit is about 2 dB(A). The reduction refers **ONLY** to the sound level radiated from the unit or in front of the unit. The noise level data on return and delivery air do not undergo reductions.

The accessory includes:

- External part as standard panel.
- Internal part in galvanized steel sheet.
- The inside noise insulation with special soundproof material.

REACTION TO FIRE CLASSIFICATION

On Italian territory, the classification is per the D.M. of June 26, 1984 and subsequent amendments, providing for a sort in "Classes" from 0 (non-combustible material) to 5 (extremely flammable material). The EN 13501-1 regulation is ordered in classes from A1 (non-combustible material) to F (extremely flammable material).

A comparison of the classes is not possible because the methods and evaluation criteria are completely different. The comparison table below is being considered purely indicative.

Definition	Italian classes	EN 13501-1
Non-combustible material	Class 0	A1
Combustible material, very limited contribution to fire	Class 1	A2 – B
Combustible material, limited contribution to fire	Class 2	A2 – B - C
Combustible material, medium contribution to fire	Class 3	C – D
Combustible material, highly contribution to fire	Class 4	E
Combustible material, easily flammable	Class 5	F

Is possible to provide the sandwich panels for the OVER units with air flow from the top. This implies that the air intake must necessarily be from the base of the unit with front blind panelling.

The accessory increases the unit weight:

SIZE		E0	E1	E2	E3	E4	E5	E6	E7	E8	E9
OVER											
Weight increasing (1)	kg	28	26	42	48	64	72	86	100	115	--
UNDER											
Weight increasing (1)	kg	28	30	48	55	70	86	110	130	145	165

1. Add this value to the total unit weight

OPTIONAL ACCESSORIES: P151 – LOWERED DISPLAY FOR UNDER

For machines installed above the supply plenum. The display / keypad on the front panel of the machine is installed lowered by about 50cm to facilitate consultation and use.



MACHINE DRAWINGS

Dimensions in mm – UNDER E0

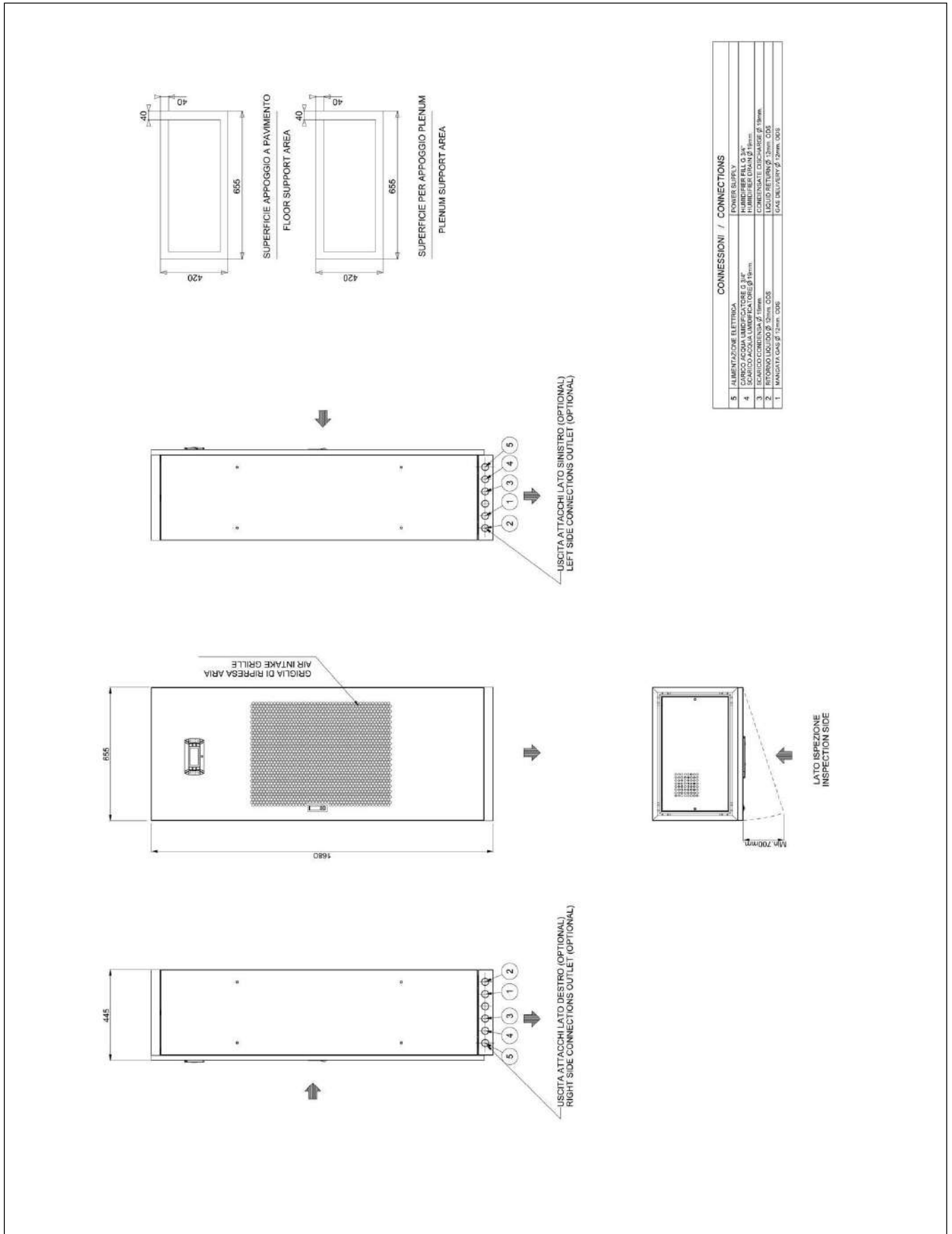

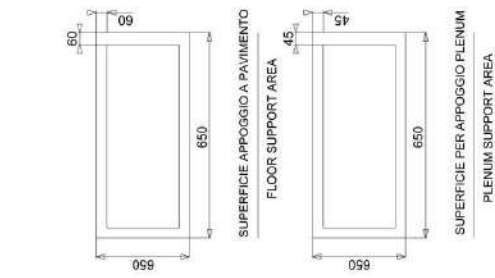

- * CON SERRANDA DI NON RITORNO
ALTEZZA TOTALE = 2095
- * WITH NON RETURN MOTORIZED DAMPER
TOTAL HEIGHT = 2085

CONNESSIONI / CONNECTIONS	
13	USCITA ACQUA DUAL FLUID SYSTEM R 1
12	INGRESSO ACQUA DUAL FLUID SYSTEM R 1
5	ALIMENTAZIONE ELETTRICA
4	SCARICO ACQUA CONDENSATA
3	SCARICO LIQUIDO
2	RETORNO LIQUIDO
1	MANDATA GAS
	DUAL FLUID SYSTEM INLET R 1
	POWER SUPPLY
	HUMIDIFIER R 1
	CONDENSATE DISCHARGE
	LIQUID RETURN
	GAS DELIVERY

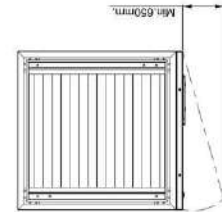
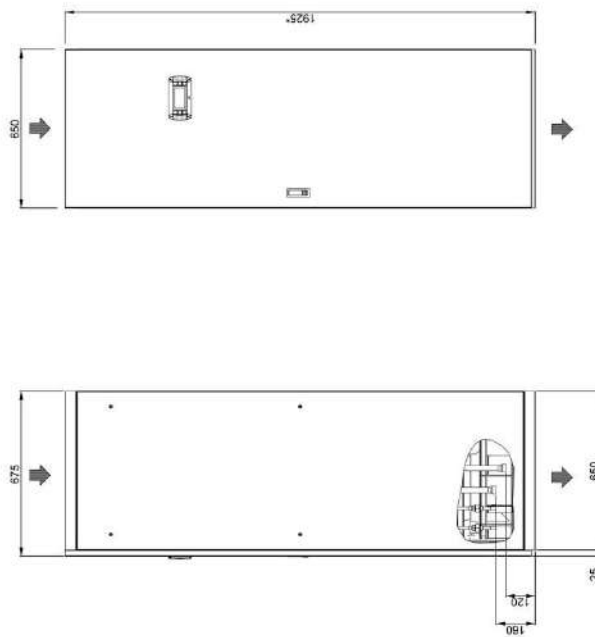
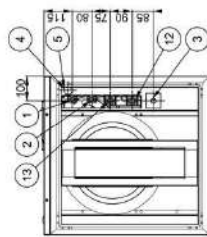

LATO ISPEZIONE
INSPECTION SIDE

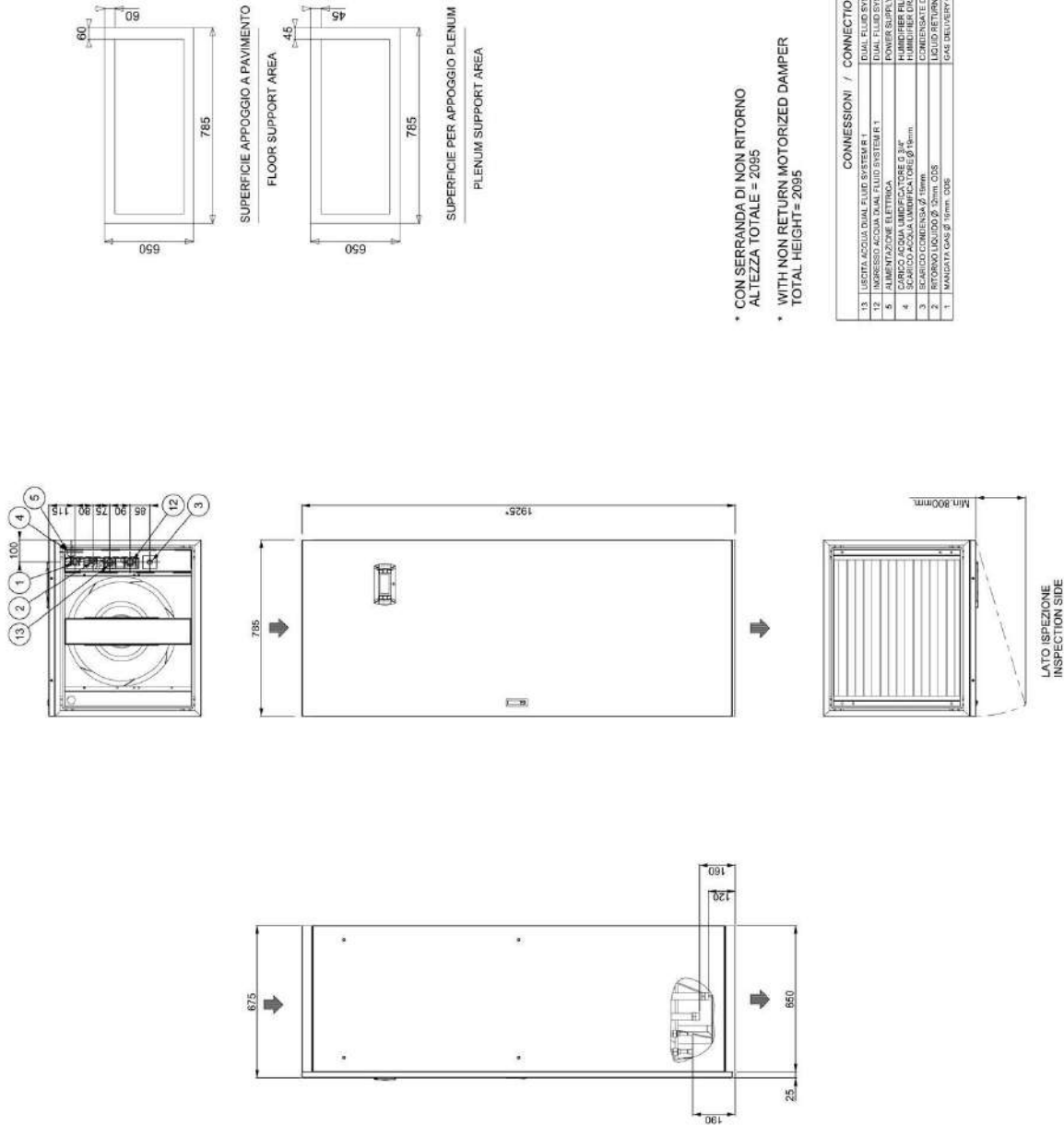

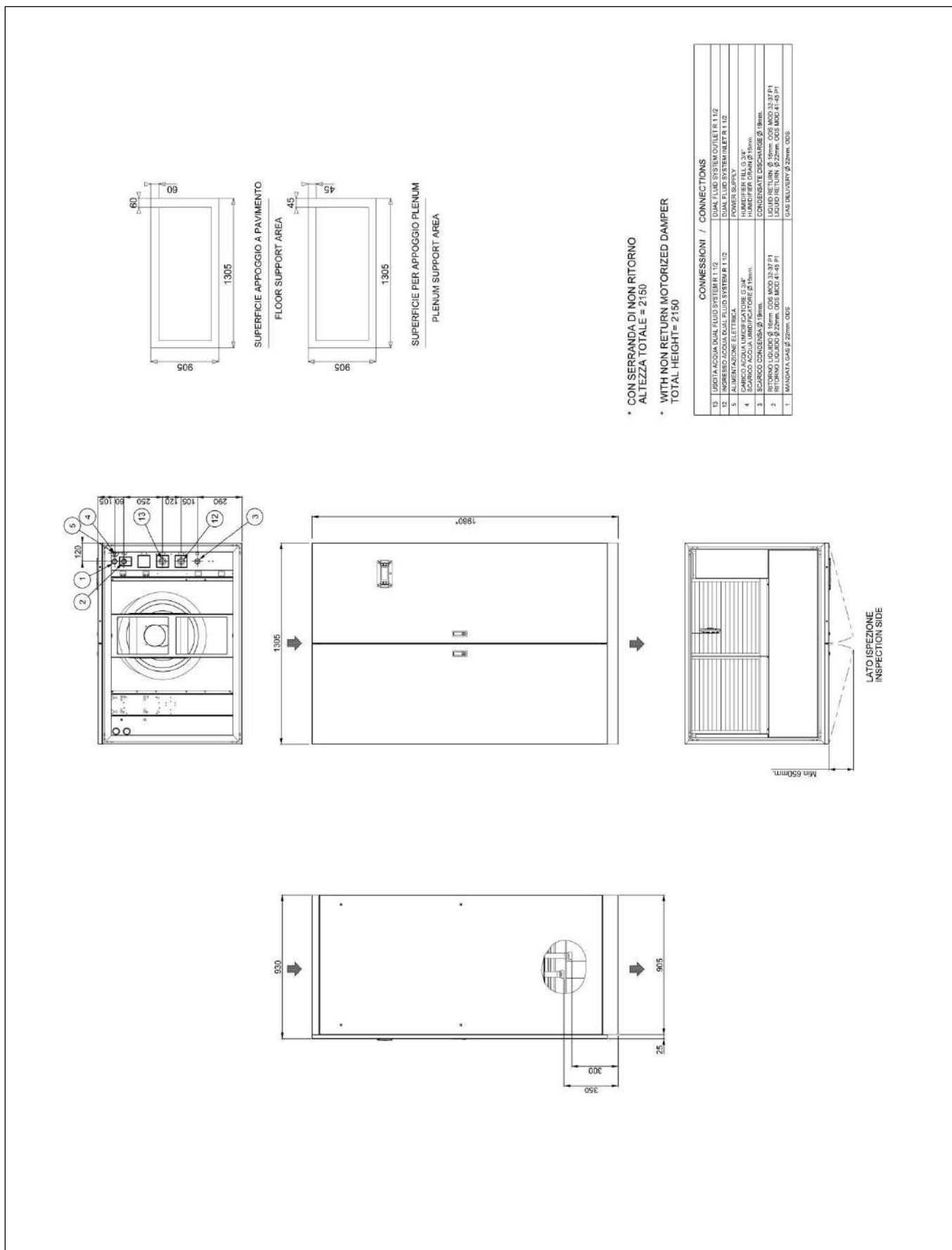

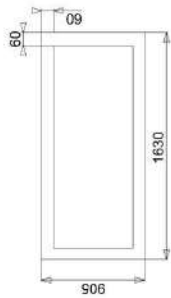
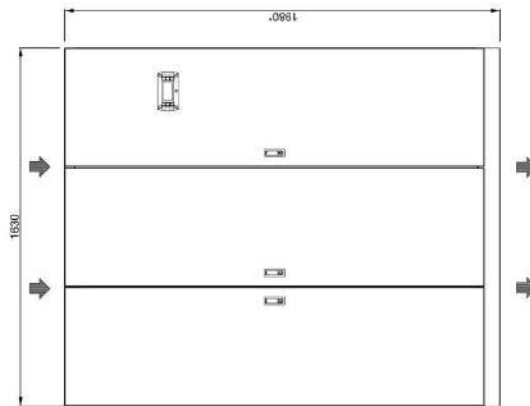
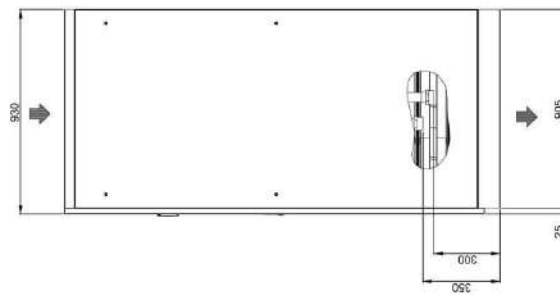
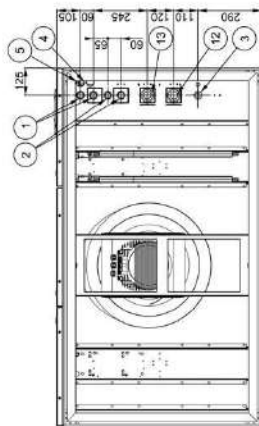

SUPERFICIE APPOGGIO A PAVIMENTO
FLOOR SUPPORT AREA

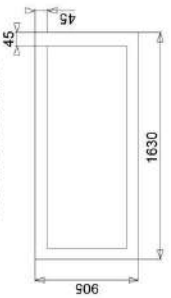

SUPERFICIE PER APPOGGIO PLENUM
PLENUM SUPPORT AREA

- CON SERRANDA DI NON RITORNO
ALTEZZA TOTALE = 2150
- WITH NON RETURN MOTORIZED DAMPER
TOTAL HEIGHT= 2150

CONNESSIONI / CONNECTIONS	
13	USCITA ACQUA DUAL FLUID SYSTEM R 2
12	INGRESSO ACQUA DUAL FLUID SYSTEM R 2
5	ALIMENTAZIONE ELETTRICA
4	SCARICO ACQUA UMIDIFICAZIONE R 2
3	SCARICO CONDENSATO Ø 38mm
2	RITORNO LIQUIDO N.2 Ø 38mm. CO2
1	MANDATA GAS N.2 Ø 16mm. CO2
	DUAL FLUID SYSTEM OUTLET R 2
	DUAL FLUID SYSTEM INLET R 2
	POWER SUPPLY
	WATER SUPPLY
	HUMIDIFIER DRAIN Ø 16mm
	CONDENSATE DISCHARGE Ø 38mm
	LIQUID RETURN N.2 Ø 38mm. CO2
	GAS DELIVERY N.2 Ø 16mm. CO2

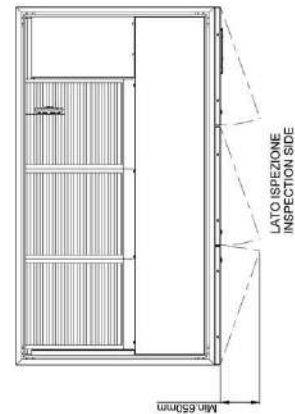

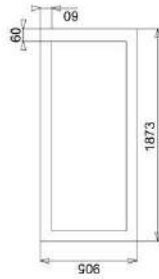
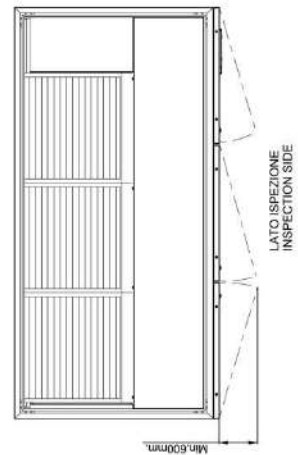
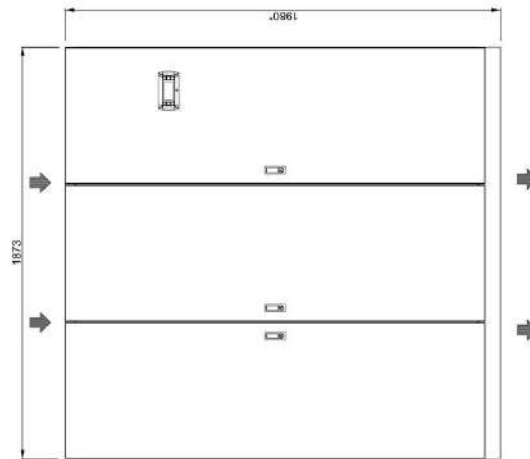
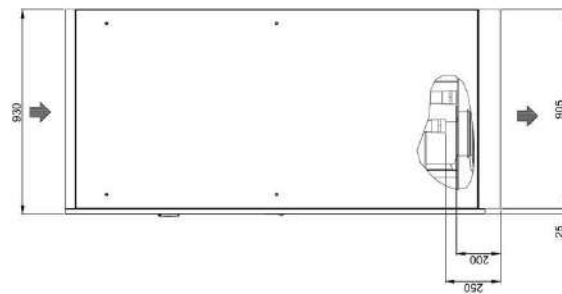
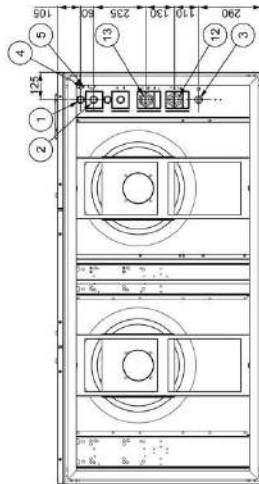

SUPERFICIE APPOGGIO A PAVIMENTO
FLOOR SUPPORT AREA



SUPERFICIE PER APPOGGIO PLENUM
PLENUM SUPPORT AREA

* CON SERRANDA DI NON RITORNO
ALTEZZA TOTALE = 2150

* WITH NON RETURN MOTORIZED DAMPER
TOTAL HEIGHT= 2150

CONNESSIONI / CONNECTIONS	
13	USCITA ACQUA DUAL FLUID SYSTEM R 2
12	INGRESSO ACQUA DUAL FLUID SYSTEM R 2
5	ALIMENTAZIONE ELETTRICA
4	SARCO ACQUA LIQUIDA N°2 Ø 22mm, CDS
3	SCARICO CONDENSATO Ø 13mm, CDS
2	RITORNO LIQUIDO N°2 Ø 22mm, CDS
1	MANDATA GAS N°2 Ø 22mm, CDS
	DUAL FLUID SYSTEM INLET R 2
	POWER SUPPLY
	LIQUID RETURN N°2 Ø 22mm, CDS
	CONDENSATE DISCHARGE Ø 13mm, CDS
	LIQUID RETURN N°2 Ø 22mm, CDS
	GAS DELIVERY N°2 Ø 22mm, CDS

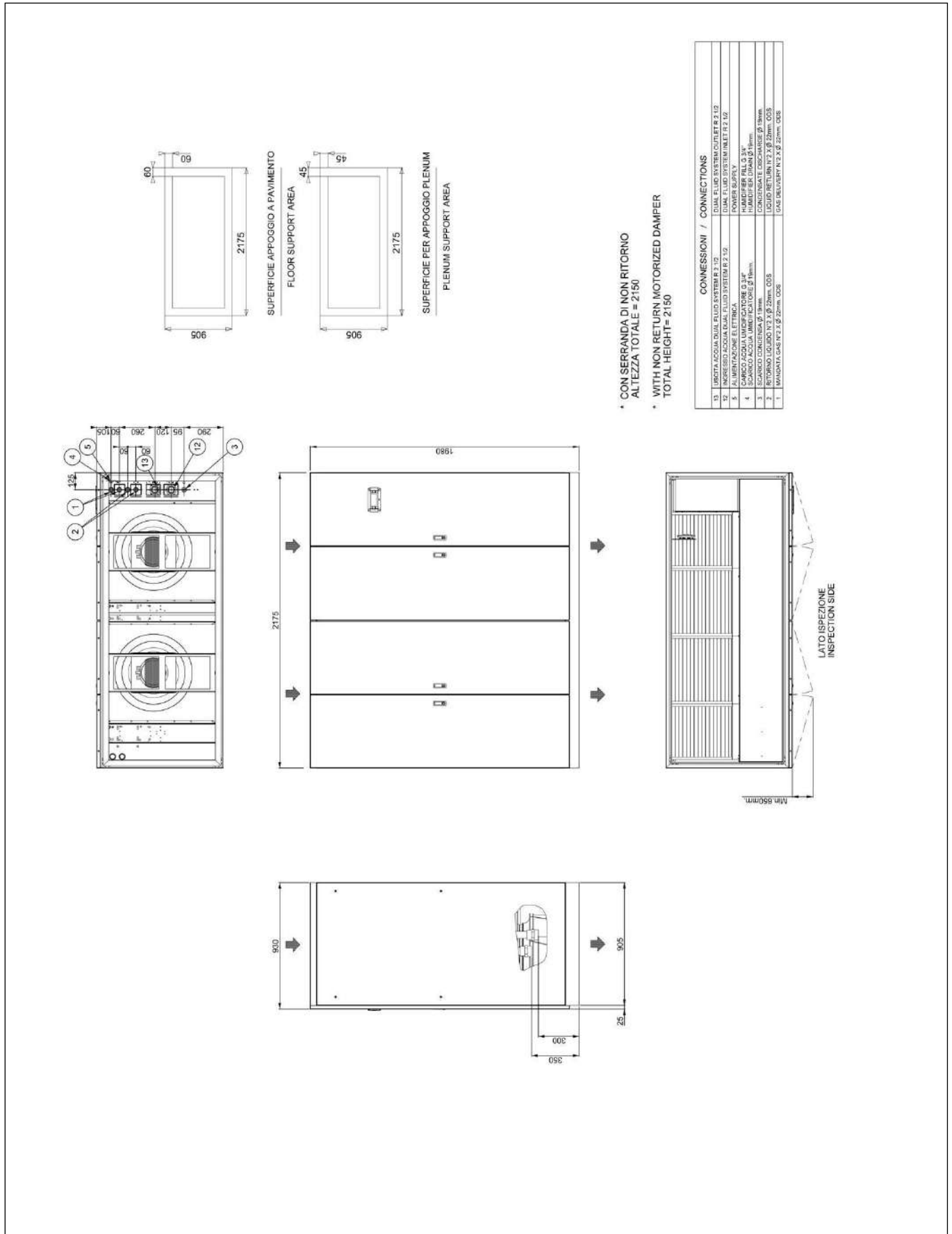

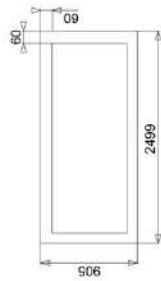
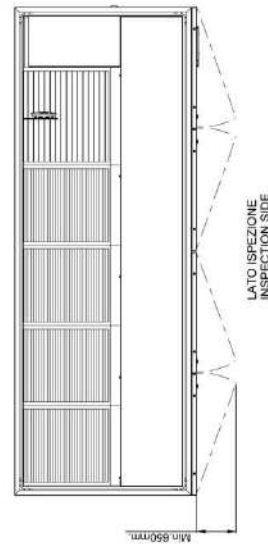
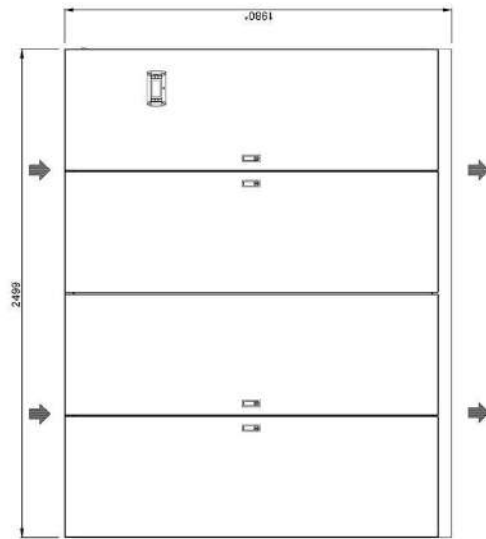
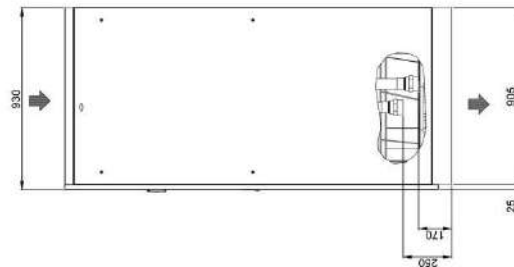
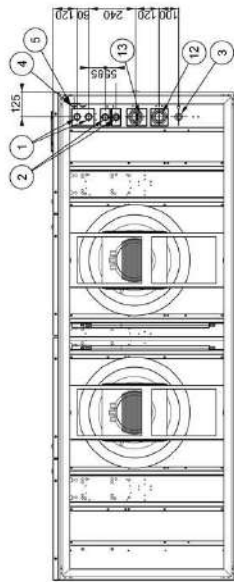

SUPERFICIE APPOGGIO A PAVIMENTO
FLOOR SUPPORT AREA

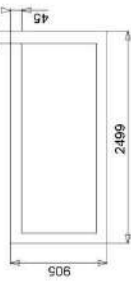

SUPERFICIE PER APPOGGIO PLENUM
PLENUM SUPPORT AREA

* CON SERRANDA DI NON RITORNO
ALTEZZA TOTALE = 2150

* WITH NON RETURN MOTORIZED DAMPER
TOTAL HEIGHT= 2150

CONNESSIONI / CONNECTIONS	
13	USCITA ACQUA DUAL FLUID SYSTEM R 2.1/2
12	DUAL FLUID SYSTEM OUTLET R 2.1/2
5	ALIMENTAZIONE ELETTRICA
5	DUAL FLUID SYSTEM INLET R 2.1/2
4	POWER SUPPLY
3	SARCO ACQUA LIQUIDA INLET R 2.1/2
3	LIQUID INLET R 2.1/2
4	SARCO ACQUA LIQUIDA OUTLET R 2.1/2
4	LIQUID OUTLET R 2.1/2
3	SGARCO CONDENSATO Ø 38mm
3	CONDENSATE DISCHARGE Ø 38mm
2	RITORNO LIQUIDO N°2 Ø25 25mm ODG
2	LIQUID RETURN N°2 Ø25 25mm ODG
1	MANDATA GAS N°2 Ø25 25mm ODG
1	GAS DELIVERY N°2 Ø25 25mm ODG

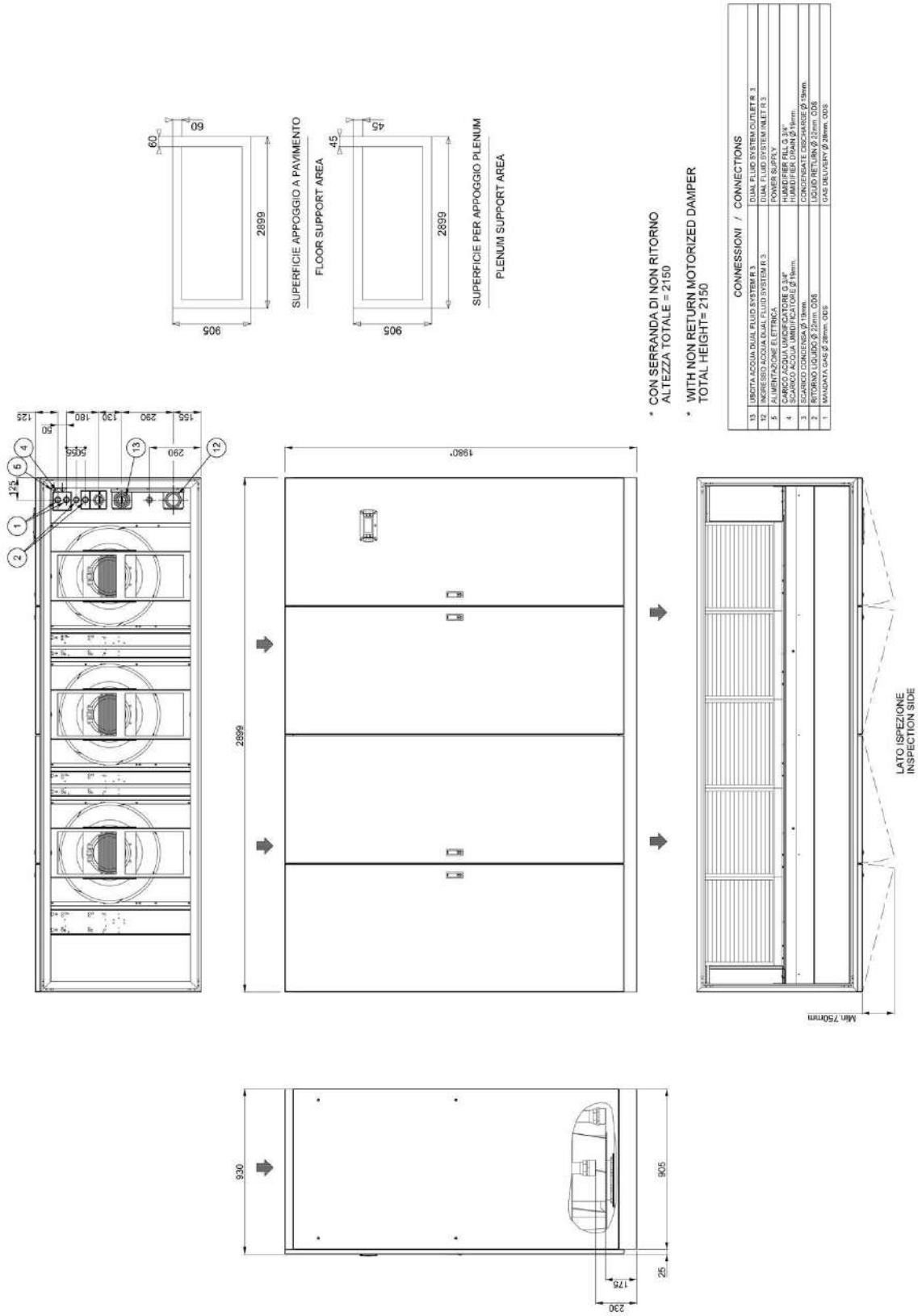

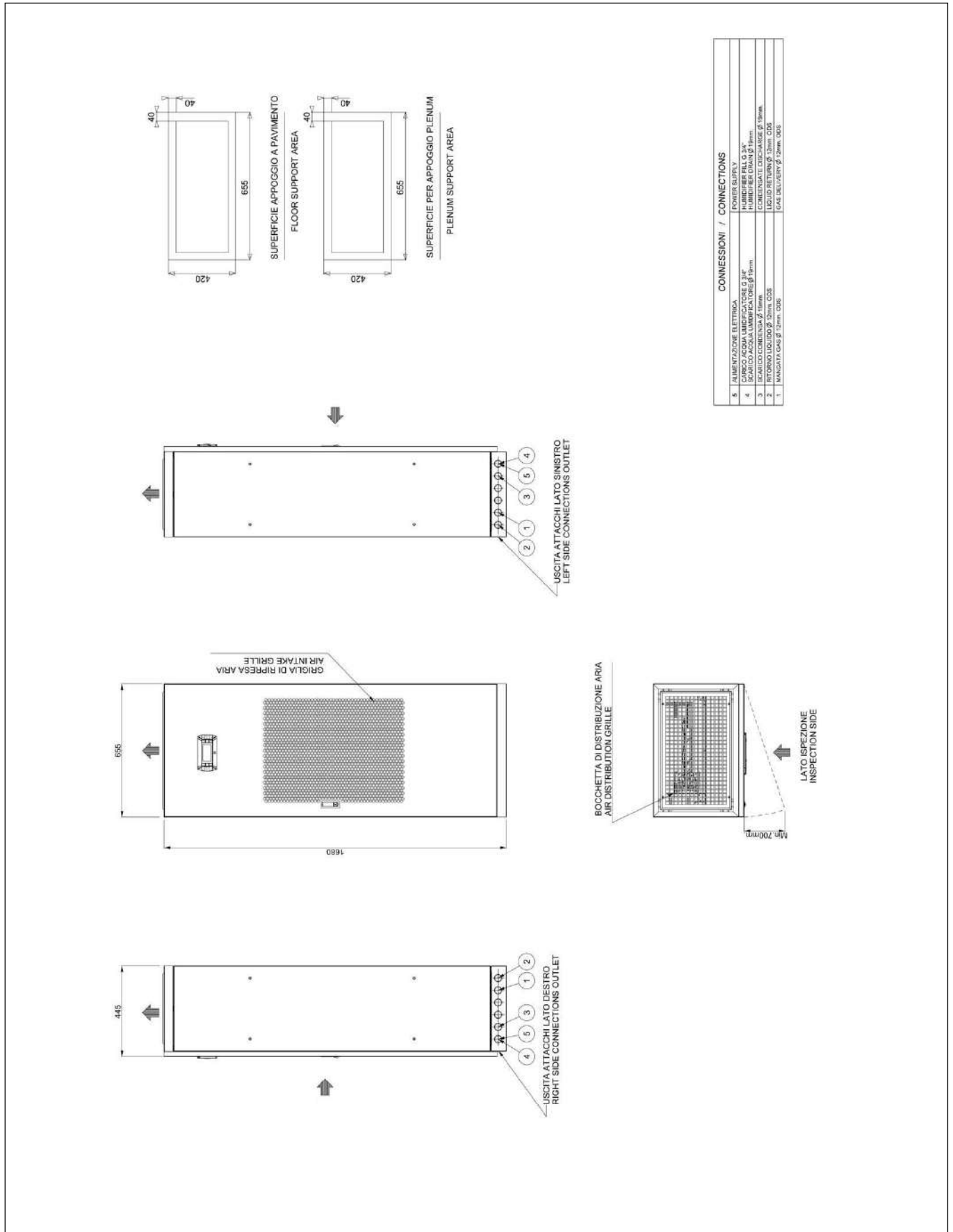

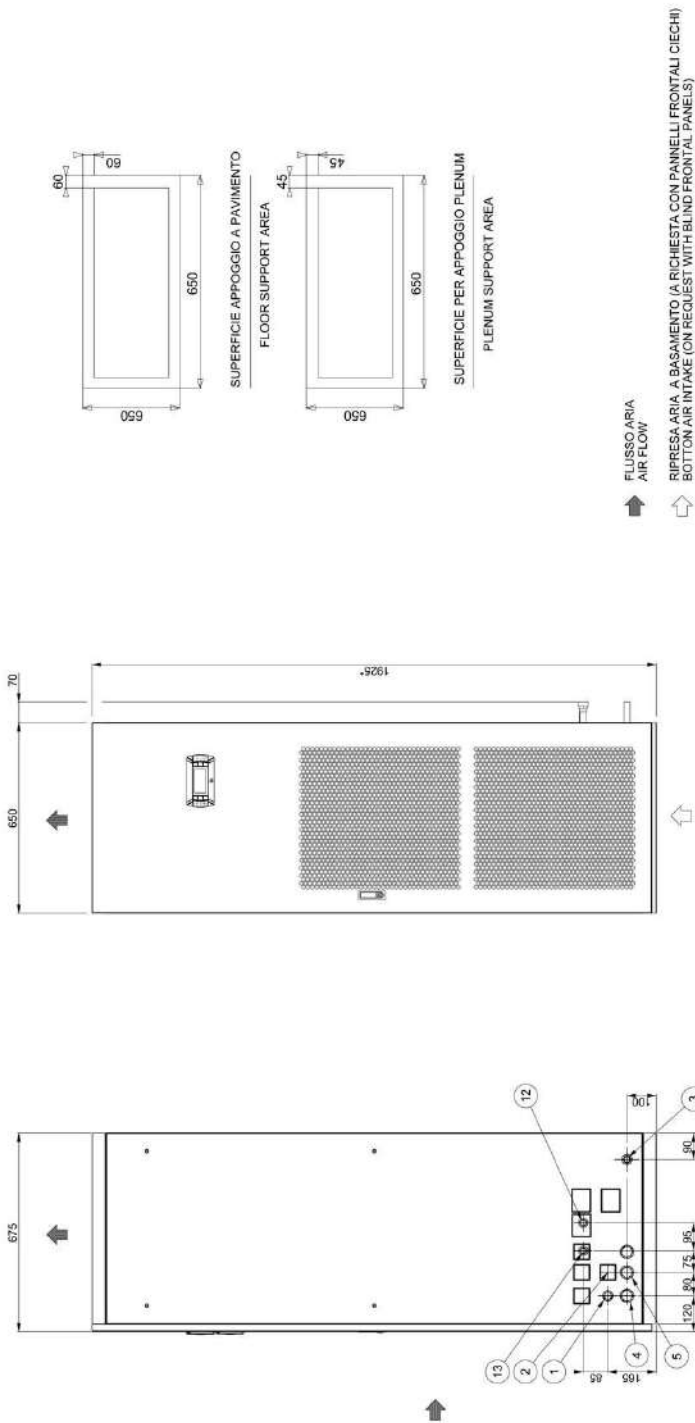

↑ FLUSSO ARIA
AIR FLOW

↑ RIPRESA ARIA A BASAMENTO (A RICHIESTA CON PANNELLI FRONTALI CIECHI)
BOTTOM AIR INTAKE (ON REQUEST WITH BLIND FRONTAL PANELS)

* CON SERRANDA DI NON RITORNO
ALTEZZA TOTALE = 2085

* WITH NON RETURN MOTORIZED DAMPER
TOTAL HEIGHT = 2085

CONNESSIONI / CONNECTIONS	
13	USCITA ACQUA DUAL FLUID SYSTEM R.1 DUAL FLUID SYSTEM OUTLET R.1
12	INGRESSO ACQUA DUAL FLUID SYSTEM R.1 DUAL FLUID SYSTEM INLET R.1
5	ALIMENTAZIONE ELETTRICA POWER SUPPLY
4	SCARICO ACQUA UMIDIFICAZIONE HUMIDIFIER DISCHARGE
3	SCARICO LIQUIDO LIQUID DISCHARGE Ø 19mm
2	RITORNO LIQUIDO Ø 19mm ODS LIQUID RETURN Ø 19mm ODS
1	MANCATA GAS Ø 19mm ODS GAS DELIVERY Ø 19mm ODS

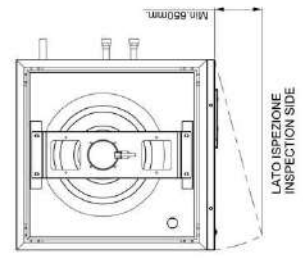

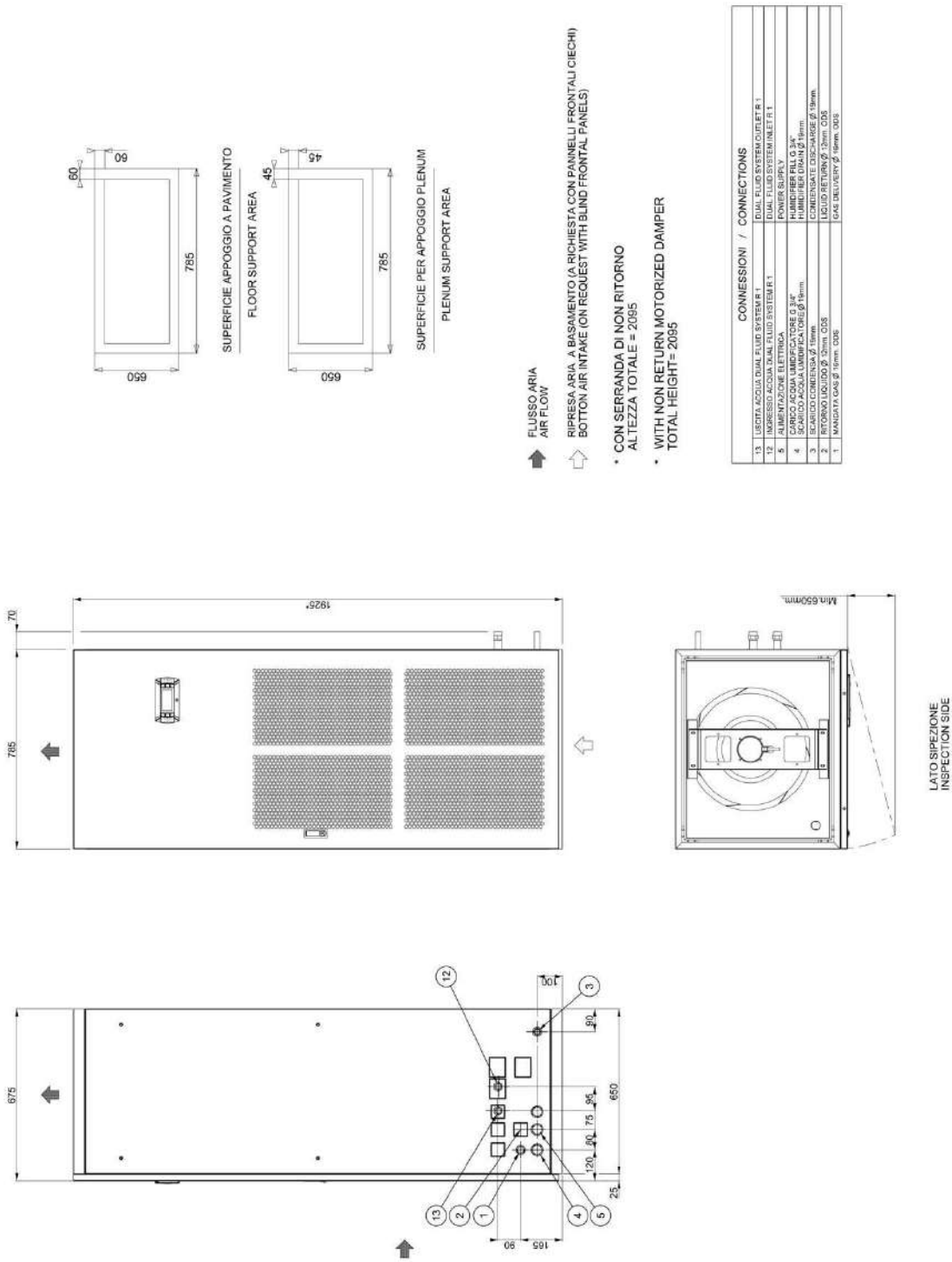

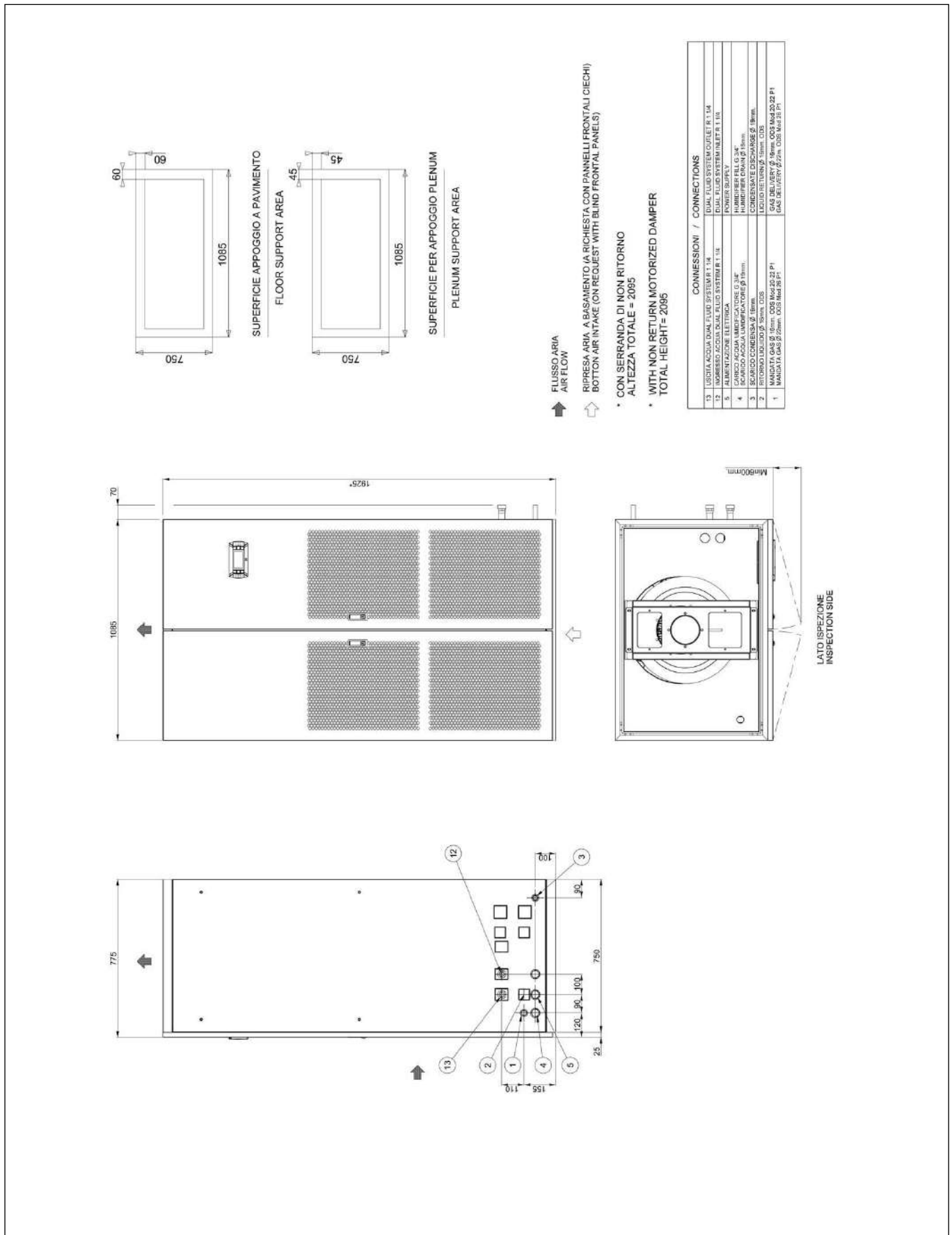

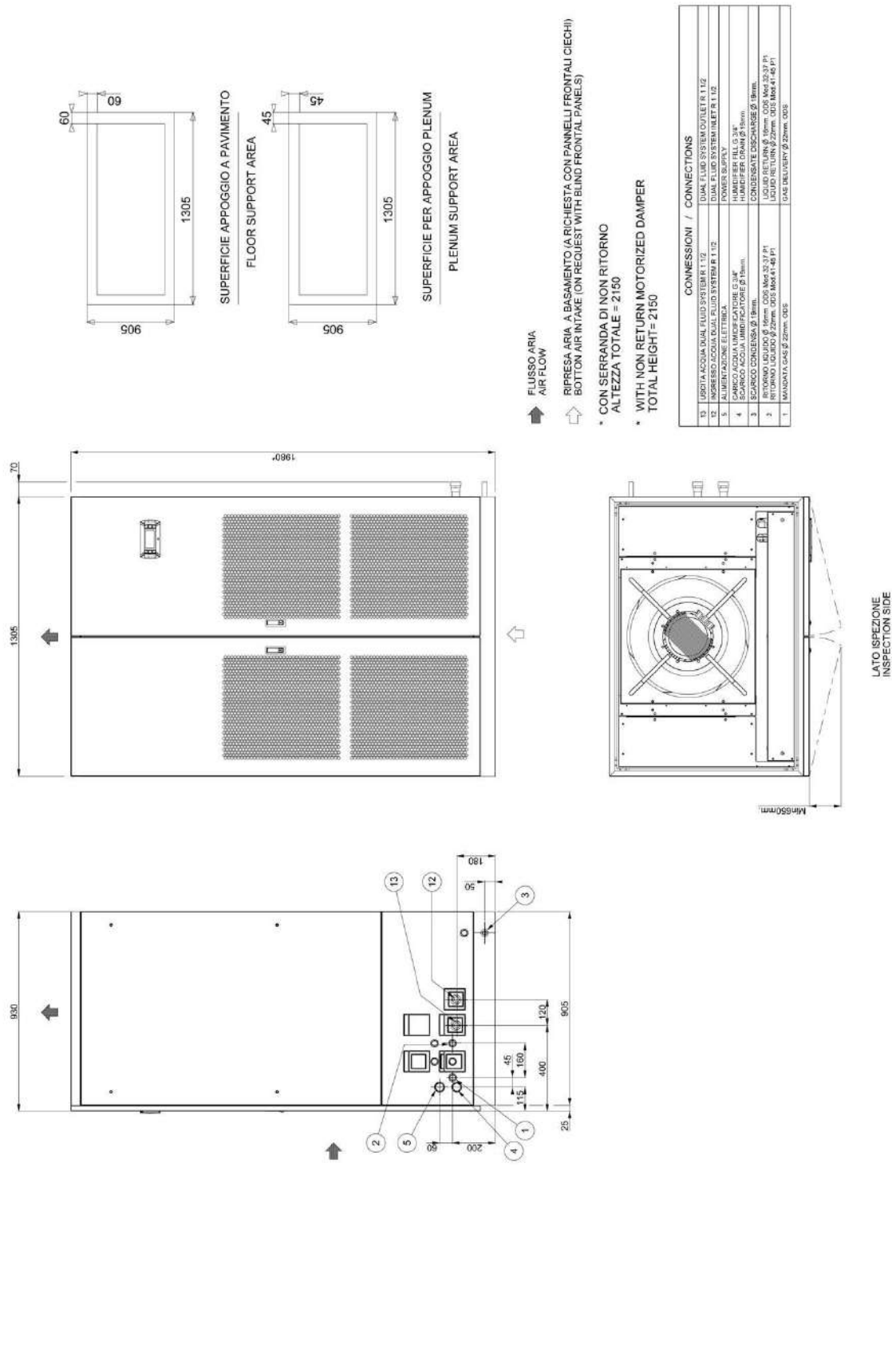

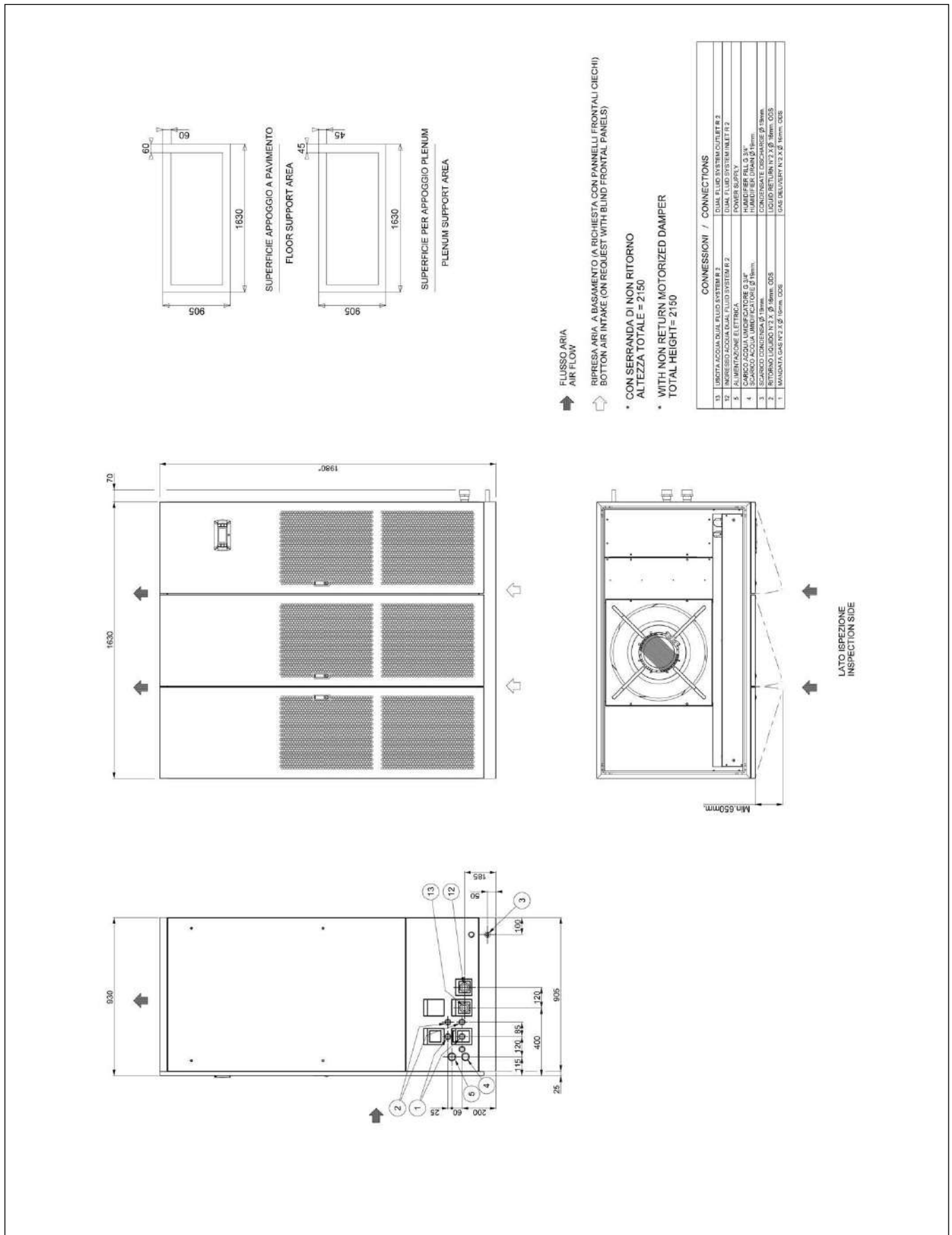

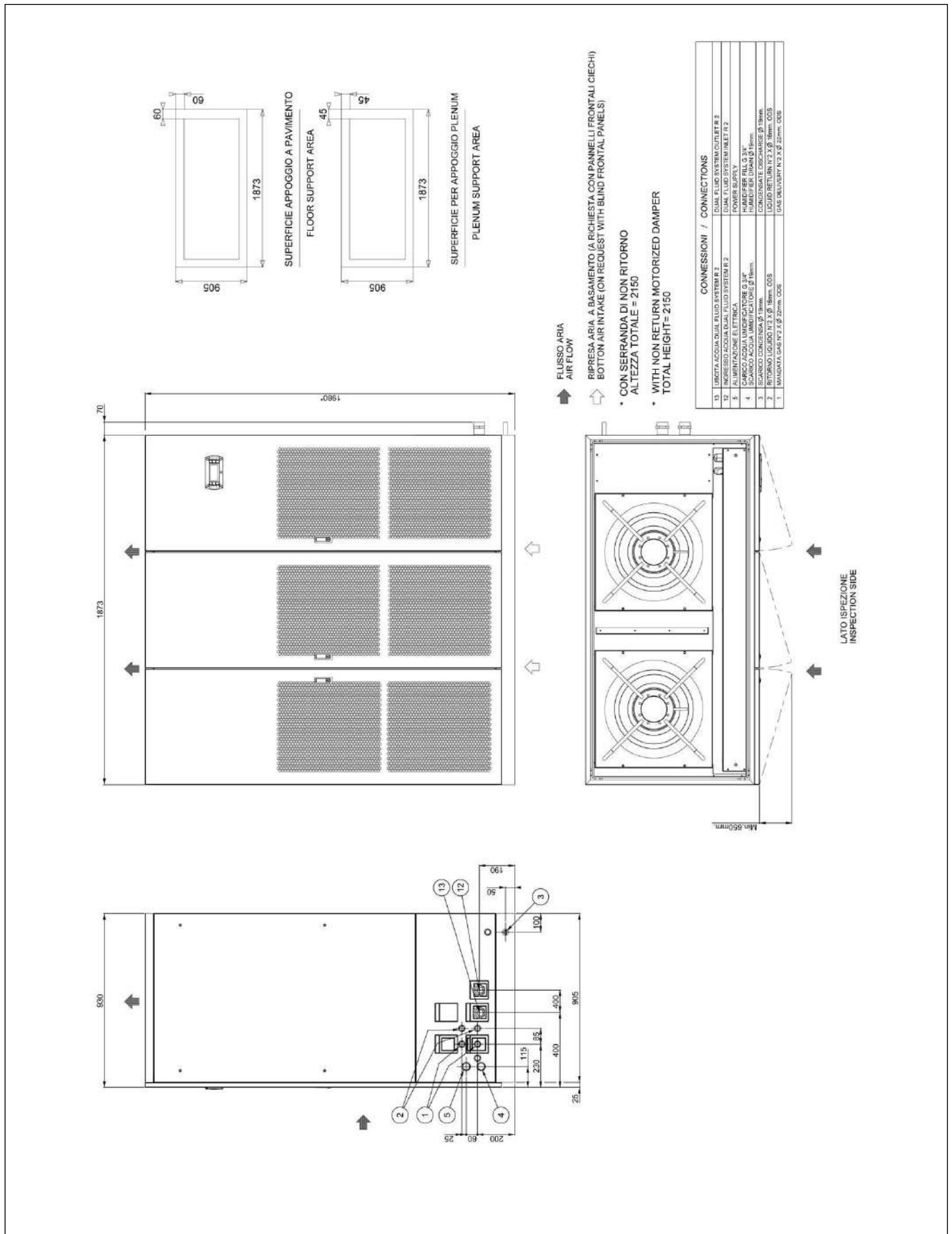

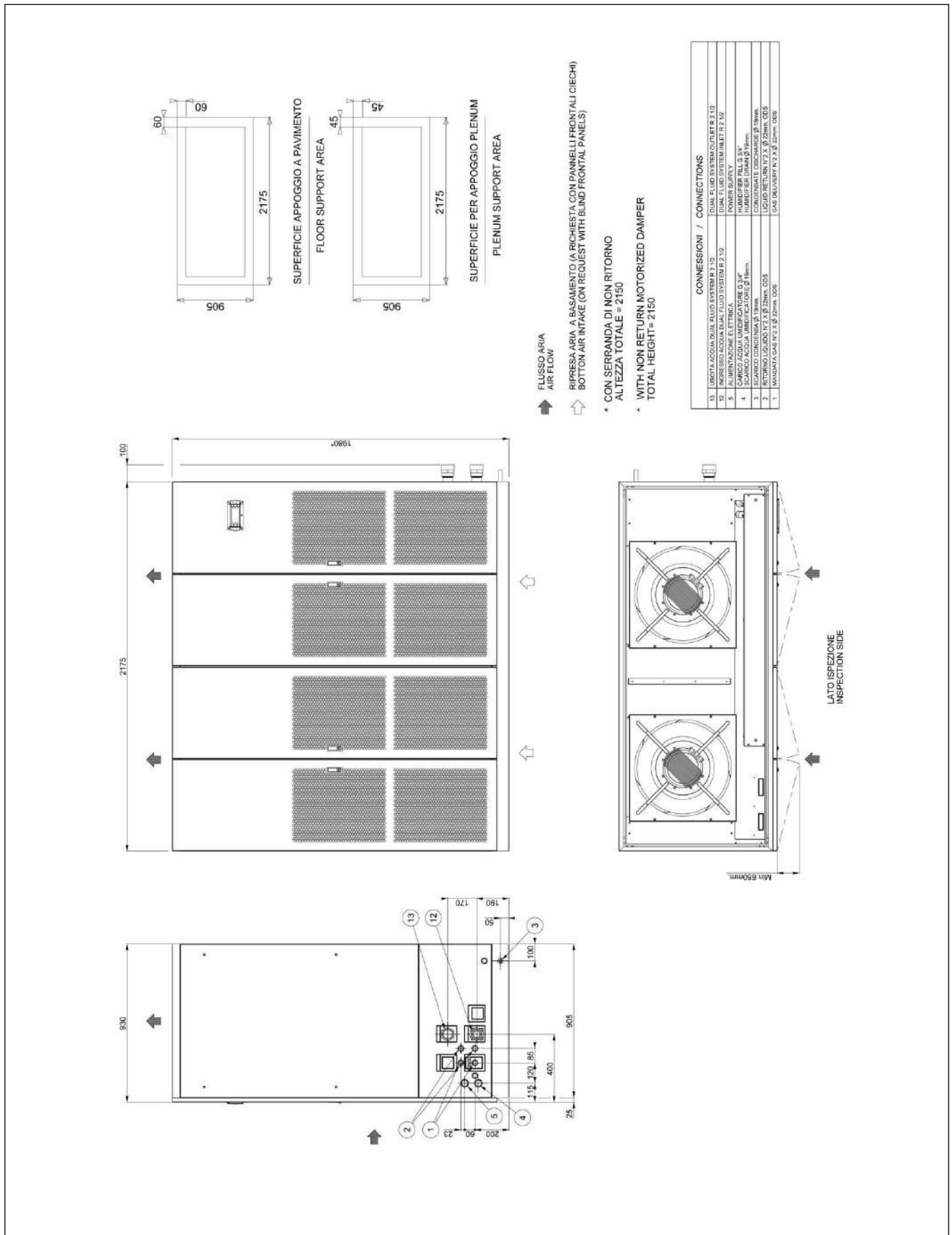

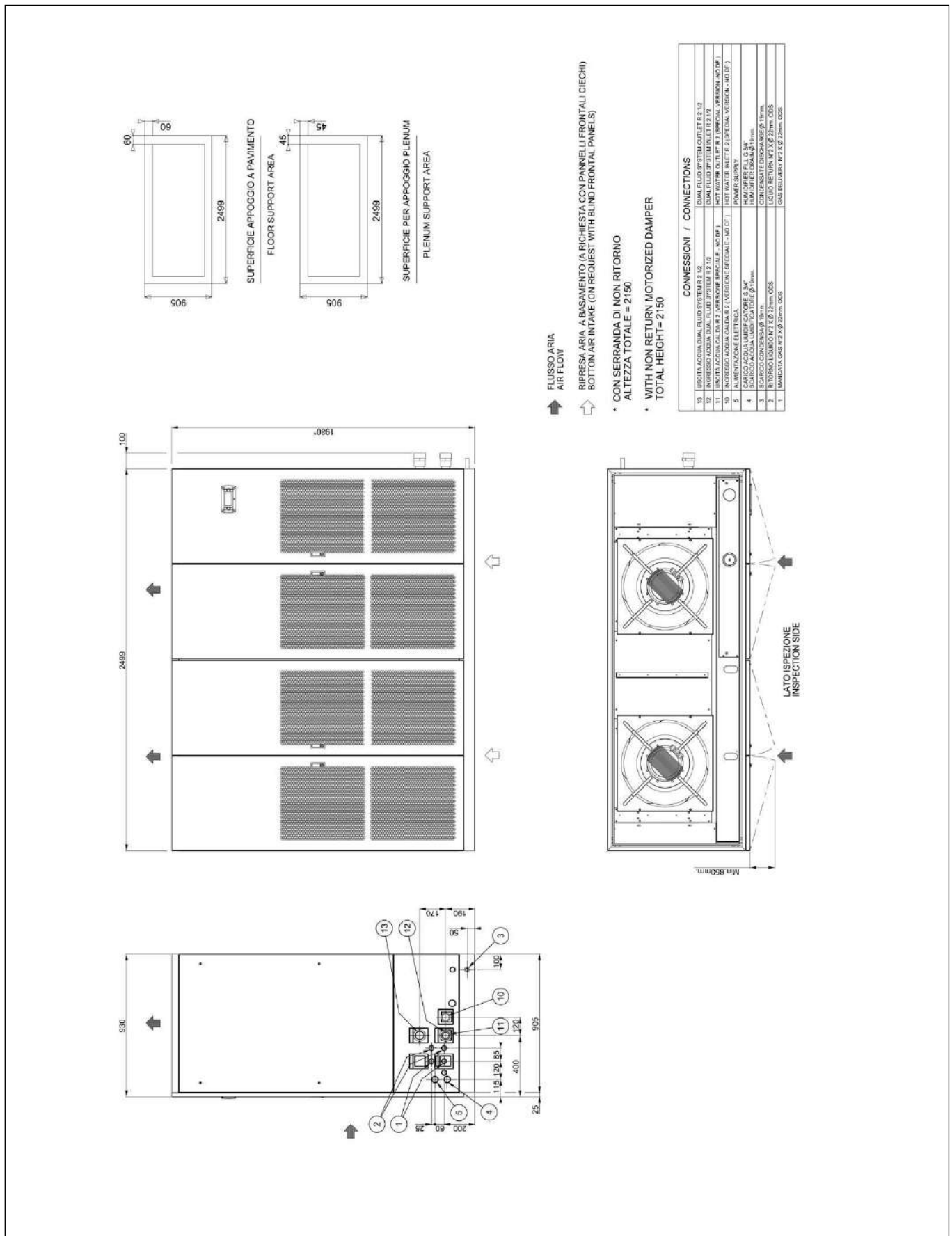

HOLE IN THE RAISED FLOOR FOR DOWNFLOW VERSION

HOLE IN THE RAISED FLOOR WITHOUT FLOOR STAND

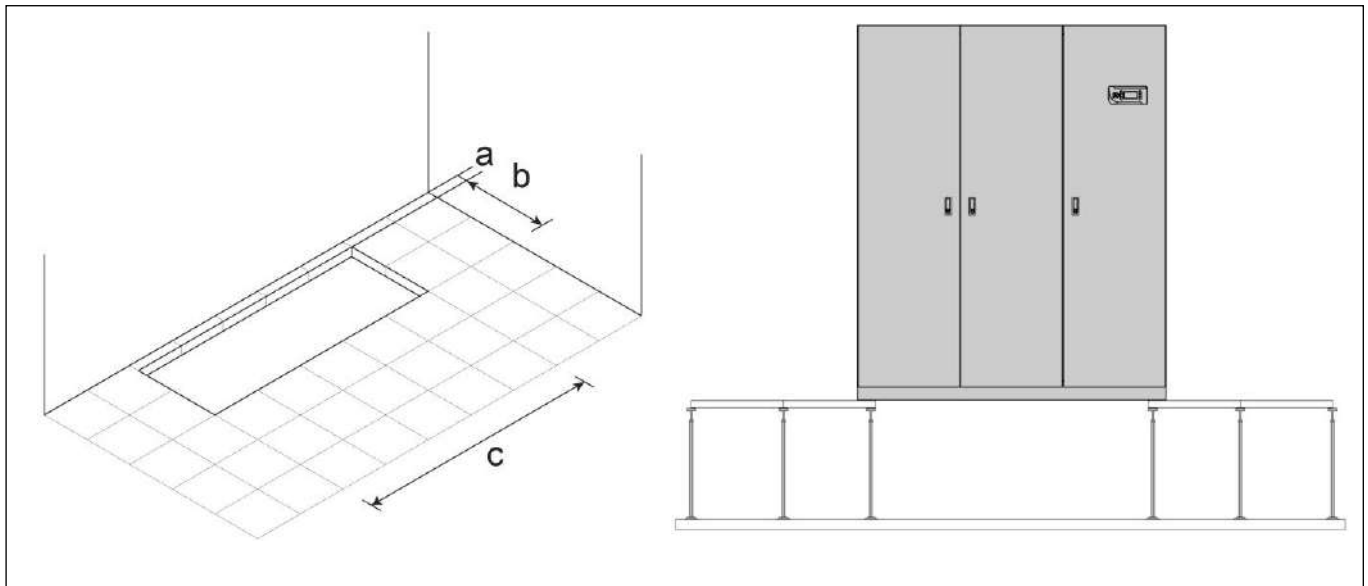

Foresee a hole in the floor with the following dimensions:

SIZE		E0	E1	E2	E3	E4	E5	E6	E7	E8	E9
a	mm	90	95	95	95	110	110	110	110	110	110
b	mm	340	560	560	660	785	785	785	785	785	785
c	mm	585	560	695	995	1185	1510	1755	2055	2380	2780

HOLE IN THE RAISED FLOOR WITH FLOOR STAND (OPTION)

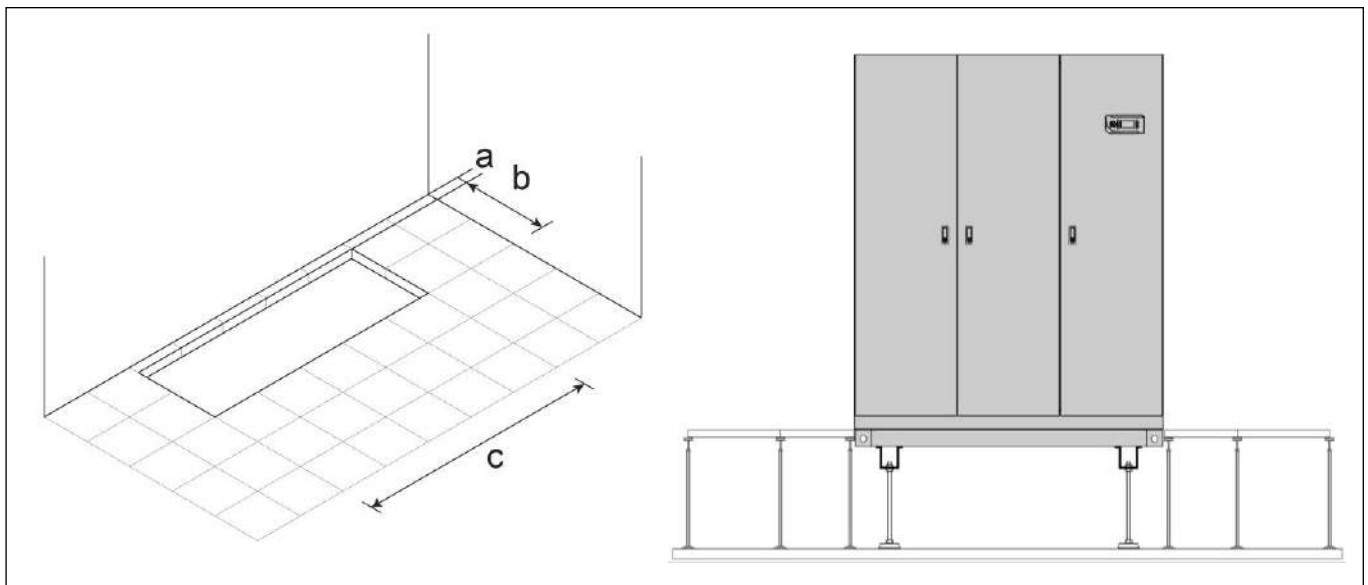

Foresee a hole in the floor with the following dimensions:

SIZE		E0	E1	E2	E3	E4	E5	E6	E7	E8	E9
a	mm	50	50	50	50	50	50	50	50	50	50
b	mm	440	670	670	770	925	925	925	925	925	925
c	mm	675	670	805	1105	1325	1650	1895	2195	2520	2920

EXAMPLE FOR MACHINES NOISE EMISSION CALCULATION

UNDER MACHINE WITH DUCT ON AIR INTAKE

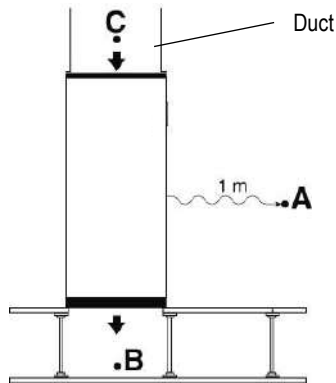

- Lp A = Front side Under catalogue value
- Lp B = Air delivery Under catalogue value
- Lp C = Air intake Under catalogue value
- The points B and C do not influence the point A

UNDER MACHINE WITH PLENUM ON AIR DELIVERY

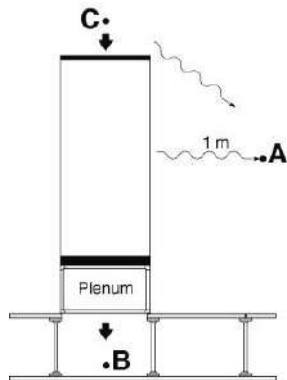

- Lp A = Front side Under catalogue value
- Lp B = Air delivery Under catalogue value – plenum noise reduction
- Lp C = Air intake Under catalogue value
- $Lp A+C = 10 \log_{10} \left(10^{\frac{LpA}{10}} + 10^{\frac{LpC}{10}} \right)$

The point B do not influence the point A

t UNDER MACHINE WITH PLENUM ON AIR INTAKE

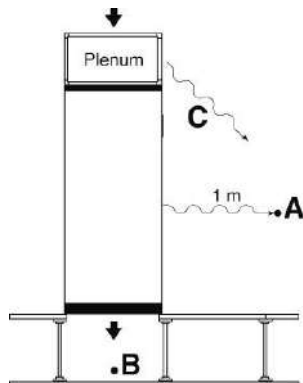

- Lp A = Front side Under catalogue value
- Lp B = Air delivery Under catalogue value
- Lp C = Air intake Under catalogue value – plenum noise reduction
- $Lp A+C = 10 \log_{10} \left(10^{\frac{LpA}{10}} + 10^{\frac{LpC}{10}} \right)$

The point B do not influence the point A

OVER MACHINE WITH DUCT

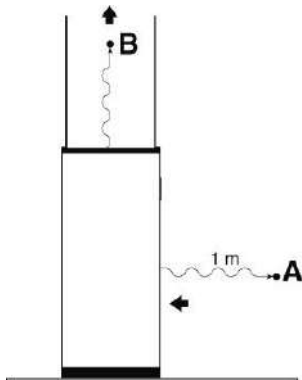

- Lp A = Air intake Over catalogue value
- Lp B = Air delivery Over catalogue value
- The point B do not influence the point A

EXAMPLE FOR MACHINES NOISE EMISSION CALCULATION

OVER MACHINE WITH PLENUM ON AIR DELIVERY

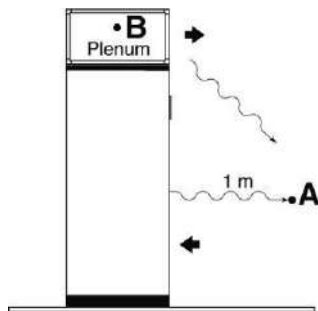

Lp A = Air intake Over catalogue value

Lp B = Air delivery Over catalogue value – plenum noise reduction

$$Lp A+B = 10 \log_{10} \left(10^{\frac{LpA}{10}} + 10^{\frac{LpC}{10}} \right)$$

OVER MACHINE WITH DUCT AND PLENUM ON AIR DELIVERY

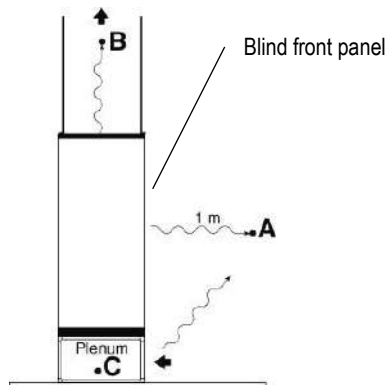

Lp A = Front side Over catalogue value

Lp B = Air delivery Over catalogue value

Lp C = Lp A + 6dB(A) – plenum noise reduction

$$Lp A+C = 10 \log_{10} \left(10^{\frac{LpA}{10}} + 10^{\frac{LpC}{10}} \right)$$

The point B do not influence the point A+C

OVER MACHINE WITH DUCT AND PLENUM ON AIR DELIVERY

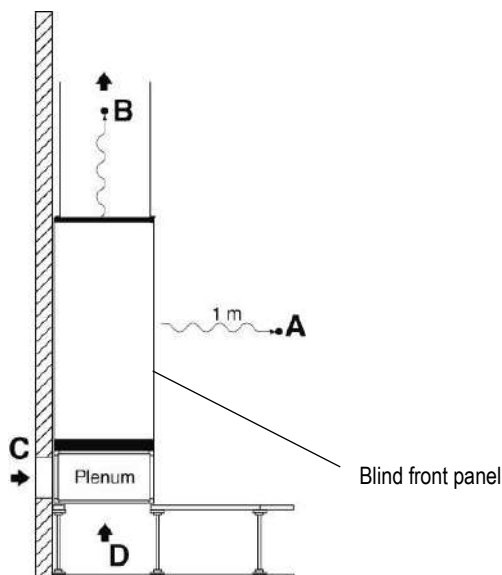

Lp A = Front side Over catalogue value

Lp B = Air delivery Over catalogue value

Lp C = Lp D = Lp A + 6 dB(A) – plenum noise reduction

The points B, C and D do not influence the point A

IMPORTANT

The declared noise levels are intended in free field conditions.

The noise pressure level of an installed unit is affected by the room acoustic characteristics.

Please consider an average noise increase of +4/+6 dB(A).

**AIR FILTERS REPLACEMENT
FOR UNDER VERSION MACHINES SIZE E4 – E5 – E6 – E7 – E8 – E9**

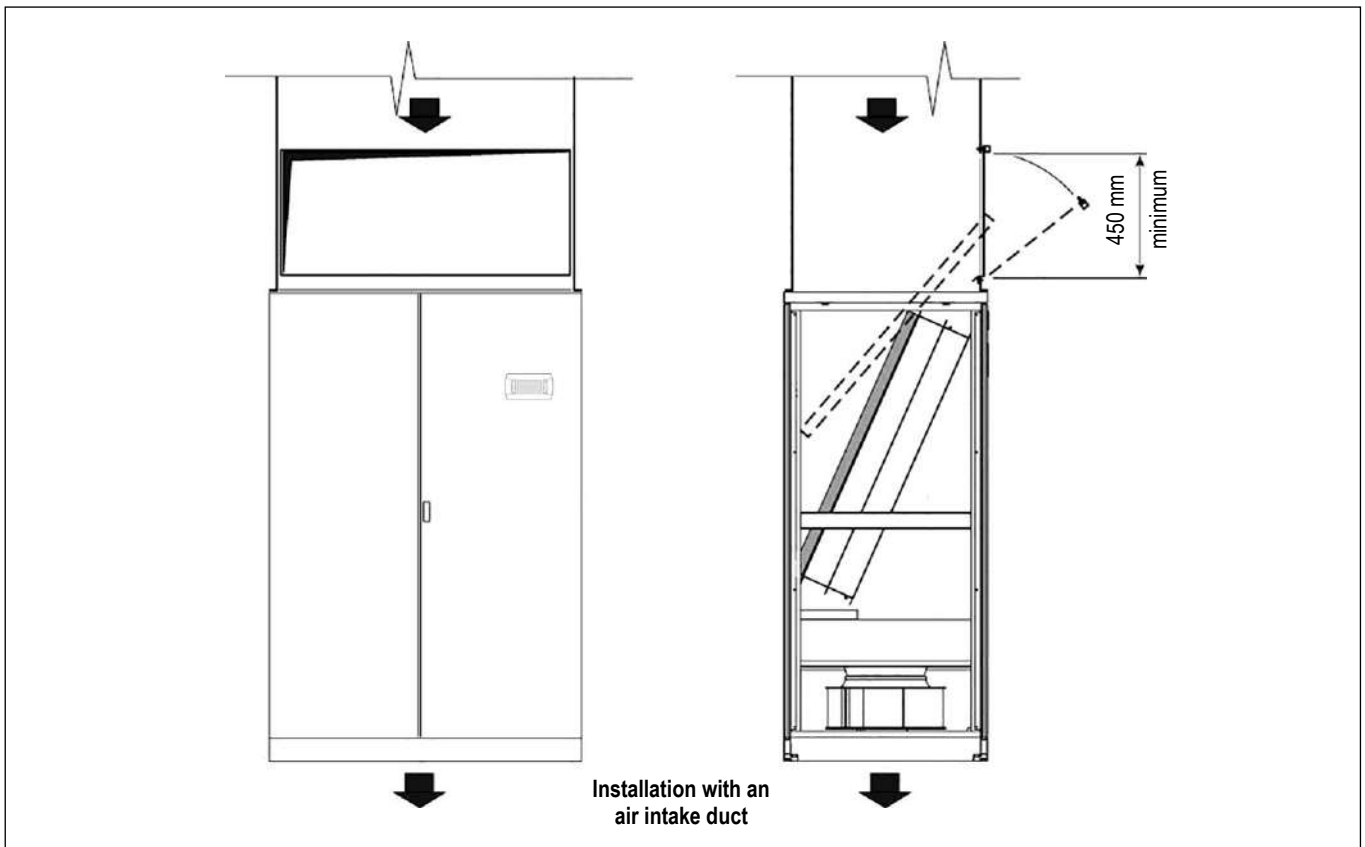
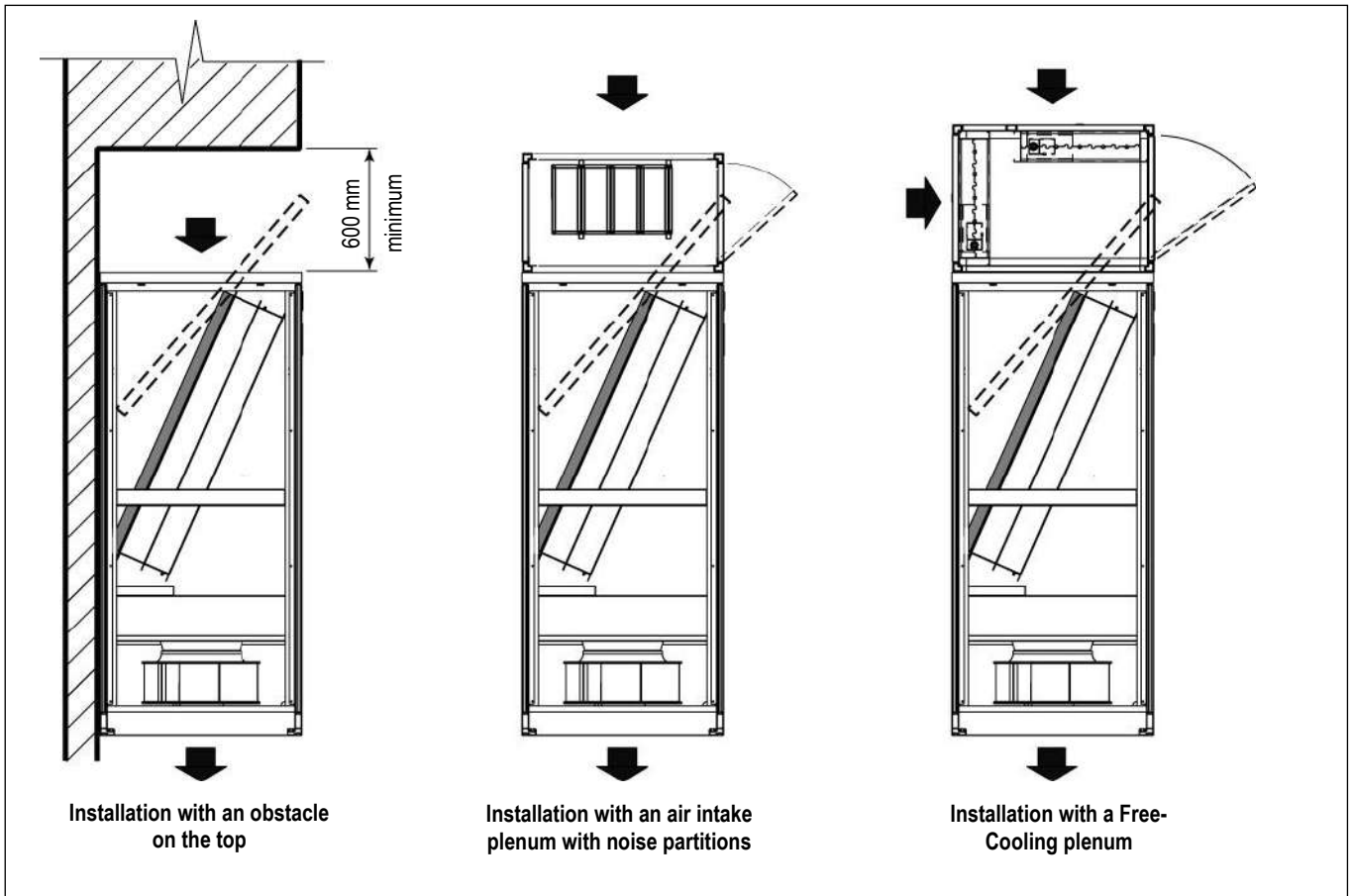

SHIPMENT: PACKING DIMENSIONS

Values referred to basic machine. The presence of some accessories increases the weight of machine.

The machines are shipped on pallet and covered with shrink wrap.
On request packing on pallet covered with shrink wrap and wooden cage.

STANDARD PACKING DIMENSIONS

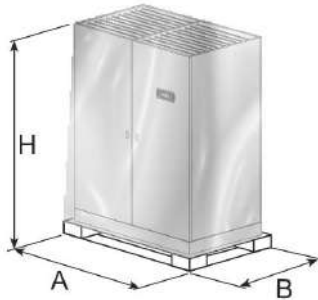

Size	A (mm)	B (mm)	H (mm)
E0	700	500	1800
E1	750	750	2080
E2	900	750	2080
E3	1200	910	2080
E4	1400	1050	2130
E5	1750	1050	2130
E6	2000	1050	2130
E7	2280	1050	2130
E8	2650	1050	2130
E9	3000	1050	2130

OPTIONAL 9973: WOODEN CAGE PACKING DIMENSIONS

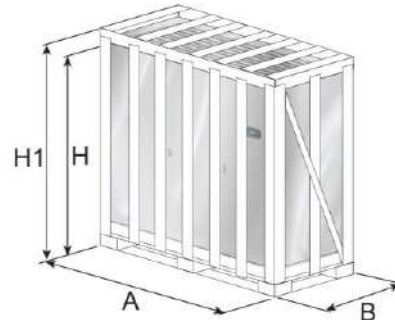

Size	A (mm)	B (mm)	H (mm)	H1 (*) (mm)
E0	740	540	1850	--
E1	790	790	2150	2350
E2	940	790	2150	2350
E3	1240	950	2150	2350
E4	1440	1090	2200	2350
E5	1790	1090	2200	2350
E6	2040	1090	2200	2350
E7	2320	1090	2200	2350
E8	2690	1090	2200	2350
E9	3040	1090	2200	2350

H1 (*) = Packing height with optional A531 on/off damper

SHIPMENT: SHIPPING WEIGHT

STANDARD PACKING

Model	007 P1	009 P1	011 P1	014 P1	016 P1	020 P1	022 P1	026 P1	032 P1	037 P1	041 P1	045 P1	
Size	S	S	S	S	S	S	S	S	S	S	S	S	
Weight UNDER	kg	170	170	252	285,2	290,2	341	346	346	449,5	454,5	466,5	474,5
Weight OVER	kg	170	170	242	275,2	280,2	321	326	326	439,5	444,5	456,5	464,5

Model	039 P2	048 P2	055 P2	062 P2	075 P2	082 P2	092 P2	102 P2	117 P4	146 P4	
Size	D	D	D	D	D	D	D	D	D	D	
Weight UNDER	kg	566	576	660,5	680,5	791	796	899,5	899,5	1081,5	1141,5
Weight OVER	kg	556	566	650,5	670,5	734	741	839,5	839,5	--	--

OPTIONAL 9973: WOODEN CAGE PACKING

Model		007 P1	009 P1	011 P1	014 P1	016 P1	020 P1	022 P1	026 P1	032 P1	037 P1	041 P1	045 P1
		S	S	S	S	S	S	S	S	S	S	S	S
Size		E0	E0	E1	E2	E2	E3	E3	E3	E4	E4	E4	E4
Weight UNDER	kg	193	193	279	313,2	318,2	373	378	378	485,5	490,5	502,5	510,5
Weight UNDER (1)	kg	--	--	301	338,2	343,2	406	411	411	529,5	534,5	546,5	554,5
Weight OVER	kg	193	193	269	303,2	308,2	353	358	358	475,5	480,5	492,5	500,5
Weight OVER (1)	kg	--	--	291	328,2	333,2	386	391	391	519,5	524,5	536,5	544,5

Model		039 P2	048 P2	055 P2	062 P2	075 P2	082 P2	092 P2	102 P2	117 P4	146 P4
		D	D	D	D	D	D	D	D	D	D
Size		E5	E5	E6	E6	E7	E7	E8	E8	E9	E9
Weight UNDER	kg	602	612	704,5	724,5	843	848	949,5	949,5	1139,5	1199,5
Weight UNDER (1)	kg	657	667	767,5	787,5	915	920	1032,5	1032,5	1237,5	1297,5
Weight OVER	kg	592	602	694,5	714,5	786	793	889,5	889,5	--	--
Weight OVER (1)	kg	647	657	757,5	777,5	858	865	972,5	972,5	--	--

(1) Machine with optional A531 on/off damper

SHIPMENT: OPTIONALS PACKING DIMENSIONS AND SHIPPING WEIGHT

- P011 - EMPTY PLENUM
- P012 - EMPTY PLENUM CL.A1
- P031 - EMPTY INTAKE PLENUM
- P032 - EMPTY INTAKE PLENUM CL.A1
- P013 - PLENUM + 3 GRILLES
- P014 - PLENUM + 3 GRILLES CL.A1
- P015 - SILENCED PLENUM
- P016 - SILENCED PLENUM + 1 GRILLE
- P017 - PLENUM + FILTER EPM2.5 50%
- P018 - PLENUM + FILTER EPM1 50%
- P019 - PLENUM + FILTER EPM1 85%

The plenums are shipped on pallet and covered with shrink wrap.

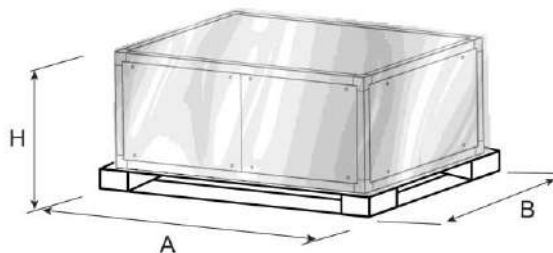

Size		E0	E1	E2	E3	E4	E5	E6	E7	E8	E9
DIMENSIONS											
A	mm	700	750	900	1200	1400	1750	2000	2280	2650	3000
B	mm	500	750	750	910	1050	1050	1050	1050	1050	1050
H	mm	630	630	630	630	630	630	630	630	630	630
SHIPPING WEIGHT											
P011 - Empty plenum "O" / "U"	kg	--	31	34	41	53	69	78	88	105	122
P012 - Empty plenum CL.A1 "O" / "U"	kg	--	36	39	47	62	79	89	100	119	137
P031 - Empty intake plenum "O" / "U"	kg	--	31	34	41	53	69	78	88	105	122
P032 - Empty intake plenum CL. A1 "O" / "U"	kg	--	36	39	47	62	79	89	100	119	137
P013 - Plenum + 3 grilles "O" / "U"	kg	23	32	35	47	68	79	96	106	135	152
P014 - Plenum + 3 grilles CL. A1 "O" / "U"	kg	26	36	40	54	77	90	107	122	151	170
P015 - Silenced plenum "O" / "U"	kg	--	36	39	47	68	81	98	113	130	152
P016 - Silenced plenum + 1 grille "O" / "U"	kg	--	41	44	54	88	101	111	126	155	182
P017 - P018 - P019 - Plenum + filter "O" / "U"	kg	--	37	39	47	68	84	98	118	135	152

"O" Over / "U" Under

P034: INTAKE FREE-COOLING PLENUM

The plenums are shipped on pallet and covered with shrink wrap.

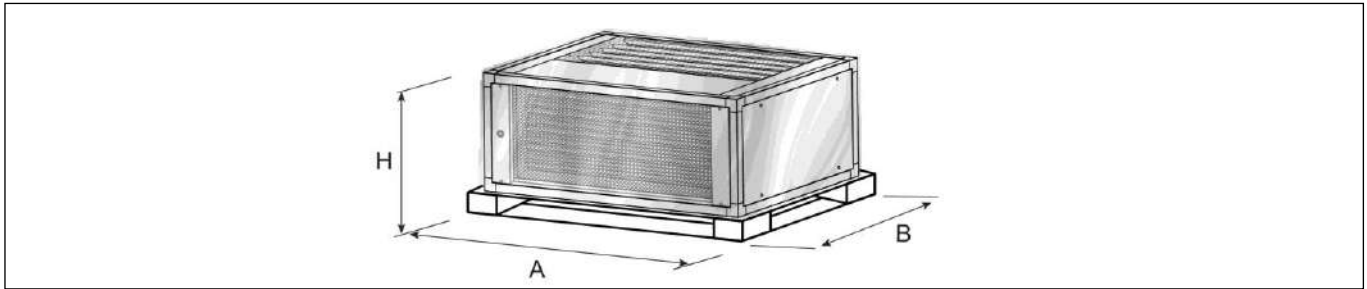

Size		E0	E1	E2	E3	E4	E5	E6	E7	E8	E9
DIMENSIONS											
A	mm	--	750	900	1200	1400	1750	2000	2280	2650	3000
B	mm	--	750	750	910	1050	1050	1050	1050	1050	1050
H	mm	--	630	630	630	750	750	750	750	750	750
SHIPPING WEIGHT											
P034 - Intake free-cooling plenum "U"	kg	--	35	39	52	76	90	111	128	155	182
P034 - Intake free-cooling plenum "O"	kg	--	35	39	52	76	90	111	128	155	182

"O" Over / "U" Under

P041 / P042 / P043: SUPPORT FRAME

The support frames are shipped on pallet and covered with shrink wrap.

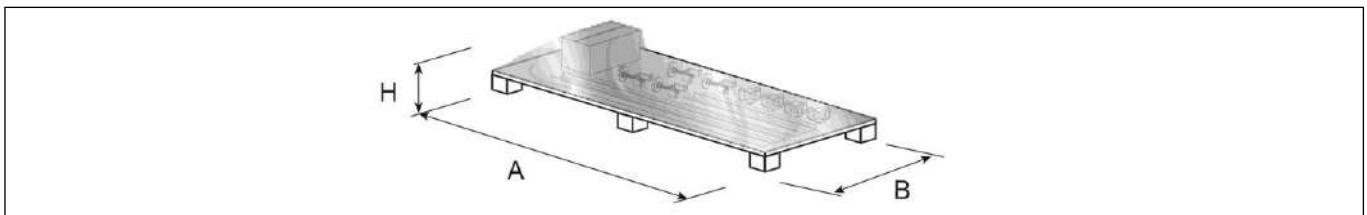

Size		E0	E1	E2	E3	E4	E5	E6	E7	E8	E9
DIMENSIONS											
A	mm	1200	1200	1200	1200	1400	1750	2000	2280	2650	3000
B	mm	900	900	900	900	900	900	900	900	900	900
H	mm	500	500	500	500	500	500	500	500	500	500
SHIPPING WEIGHT											
	kg	25	26	27	29	37	40	44	47	49	53

P183 / P184: KIT NETWORK ANALYZER / KIT NETWORK ANALYZER+OPTIONAL
P113 / P114: DUAL POWER SUPPLY KIT / DUAL POWER SUPPLY KIT+OPTIONAL

The optional are shipped in a cardboard box.

P183 / P184 - KIT NETWORK ANALYZER / KIT NETWORK ANALYZER+OPTIONAL

Size		E0	E1	E2	E3	E4	E5	E6	E7	E8	E9
DIMENSIONS											
A	mm	--	400	400	400	--	--	--	--	--	--
B	mm	--	400	400	400	--	--	--	--	--	--
H	mm	--	210	210	210	--	--	--	--	--	--
SHIPPING WEIGHT											
	kg	--	12	12	12	--	--	--	--	--	--

P113 / P114 - DUAL POWER SUPPLY KIT / DUAL POWER SUPPLY KIT+OPTIONAL

Size		E0	E1	E2	E3	E4	E5	E6	E7	E8	E9
DIMENSIONS											
A	mm	410	410	410	410	410	--	--	--	--	--
B	mm	410	410	410	410	410	--	--	--	--	--
H	mm	210	210	210	210	210	--	--	--	--	--
SHIPPING WEIGHT											
	kg	5	5	5	5	5	--	--	--	--	--

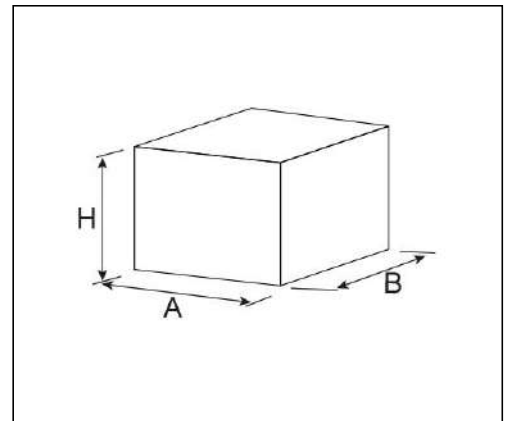



for a greener tomorrow

Eco Changes is the Mitsubishi Electric Group's environmental statement, and expresses the Group's stance on environmental management. Through a wide range of businesses, we are helping contribute to the realization of a sustainable society.



MITSUBISHI ELECTRIC HYDRONICS & IT COOLING SYSTEMS S.p.A.

Via Caduti di Cefalonia, 1 - 36061 Bassano del Grappa (VI) Italy
Ph. (+39) 0424 509 500 • Fax (+39) 0424 509 509
www.melcohit.com

