

Smart IO

IO-10MIXR-WE / IO-10MIXR-NWE

INSTALLATION INSTRUCTIONS

CONTENTS

General Safety Information 3

Technical Data 4
 Electrical Data 4
 Power Consumption 4
 Current Consumption 4
 Operational Environment 4
 Standards 4
 Other Specifications 4

Interfaces 5
 Activating Bluetooth and Resetting the device 7
 Ethernet Interfaces and LEDs 7
 Smart IO Inputs/Outputs 8
 Supported Sensors 8
 Communication Baud Rates 9

Power Supply 9
 Transformers 9
 Switch Mode Power Supply 9
 Fusing 9

Wiring and Set-up 12
 General Safety Considerations 12
 Wiring Terminals 12
 Connecting Power Supply 12
 Earth Grounding 12
 Cable Specifications 13

Wireless Connectivity 14
 Connectivity Frequency Range 14
 General Information 14

Connection Examples 15
 Voltage Input (UIO)/Thermistor Input (UIO) 15
 Digital Input (UIO) Connection 16
 Binary Output/Analog Output Connection (UIO) 17
 Current Input (UIO)/20VDC Output Connection 18
 Digital Inputs Connection 19
 Digital/Relay Outputs 20

Troubleshooting with LEDs 21
 Troubleshooting with Main LED 21
 Troubleshooting with Input/Output LEDs 22
 Troubleshooting with Bluetooth LED 23
 Troubleshooting with Wi-Fi LED 23
 Troubleshooting with the Ethernet Interface LEDs 24

Dimensions 25

Appendix: Earth Grounding 26
 Smart IO and SELV 26
 Smart IO and EN60204-1 26
 Functional EMC Grounding 26

Smart IO Part Numbers 27
 Accessories Part Numbers 27
 Remote Antenna Part Numbers 27

Technical Literature 28

GENERAL SAFETY INFORMATION

- When performing any work (installation, mounting, start-up), all manufacturer instructions and in particular these Installation and Commissioning Instructions (EN1B-0206IE10) are to be observed.
- Smart IO may be installed and mounted only by authorized and trained personnel.
- Rules regarding electrostatic discharge should be followed.
- If the Smart IO is modified in any way, except by the manufacturer, all warranties concerning operation and safety are invalidated.
- Make sure that the local standards and regulations are observed at all times. Examples of such regulations are VDE 0800 and VDE 0100 or EN 60204-1 for earth grounding.
- It is recommended that devices be kept at room temperature for at least 24 hours before applying power. This is to allow any condensation resulting from low shipping/storage temperatures to evaporate.
- The Smart IO must be installed in a manner (e.g., in a lockable cabinet) ensuring that unauthorized persons have no access to the terminals.
- Investigated according to United States Standard UL-60730-1, UL-916, and UL60730-2-9.
- Investigated according to Canadian National Standard(s) C22.2, No. 205-M1983 (CNL-listed).
- Do not open the Smart IO, as it contains no user-serviceable parts inside.
- CE declarations according to LVD Directive 2014/35/EU and EMC Directive 2014/30/EU.
- Product standards are EN 60730-1 and EN 60730-2-9 for indoor use only.
- Transmitter Antenna (From Section 6.8 RSS-GEN, Issue 5, April 2018):
 - This radio transmitter [IC: 24552-00001] has been approved by Innovation, Science and Economic Development Canada to operate with the antenna types listed below, with the maximum permissible gain indicated. Antenna types not included in this list that have a gain greater than the maximum gain indicated for any type listed are strictly prohibited for use with this device.
 - Le présent émetteur radio [IC: 24552-00001] a été approuvé par Innovation, Sciences et Développement économique Canada pour fonctionner avec les types d'antenne énumérés cidessous et ayant un gain admissible maximal. Les types d'antenne non inclus dans cette liste, et dont le gain est supérieur au gain maximal indiqué pour tout type figurant sur la liste, sont trictement interdits pour l'exploitation de l'émetteur.

Professional Installation

- This device must be professionally installed, this should be noted on grantee.
- To maintain compliance, only the antenna types that have been tested shall be used, which listed in Table 30, "Remote Antenna Part Numbers," on page 27.
- This device requires a significant technology engineering expertise towards understanding of the

tools and relevant technology, not readily available to average consumer. Only a person professionally trained in the technology is competent.

- This device is not directly marketed or sold to general public.

Safety Information as per EN60730-1

The Smart IO is intended for residential, commercial, and light-industrial environments.

The Smart IO is an independently mounted electronic control system with fixed wiring.

The Smart IO is suitable for mounting in fuse boxes conforming with standard DIN43880 and DIN19, and having a slot height of max. 45 mm.

It is suitable for panel rail mounting on 35 mm standard panel rail (both horizontal and vertical rail mounting possible).

The Smart IO is used for the purpose of building HVAC control and is suitable for use only in non-safety controls for installation on or in appliances.

Table 1. Safety Information as per EN60730-1

Electric Shock Protection	SELV
Pollution Degree	Pollution Degree 2, suitable for use in industrial environments.
Installation	Safety class: Evaluated in final product
Overvoltage Category	AC 230V for relay: Category II
Rated Impulse Voltage	330 V AC for Category I (SELV) 2500V AC for Relay output (DO)
Automatic Action	Type 1.B(micro-disconnection for relay)
Software Class	Class A
Enclosure	According to final product evaluation, meet requirements of IP20
Ball-pressure Test Temperature	>75 °C for all housing and plastic parts >125 °C in the case of devices applied with voltage-carrying parts, connectors, and terminals.
Electromagnetic Interference	Tested at 230 Vac, with the modules in normal condition.
System Transformer	Europe: safety isolating transformers according to IEC61558-2-6 U.S.A. and Canada: NEC Class-2 transformers

TECHNICAL DATA

Electrical Data

Table 2. Electrical Data

Operating Voltage (AC)	19 to 29Vac (50/60Hz)
Operating Voltage (DC)	23 to 29Vdc
Screw-type Terminals	Max. 2.5 mm ² (Or Max.12AWG)
Overvoltage Protection	Protected against overvoltages of max. 29 Vac or 40 Vdc, terminals protected against short-circuiting.

NOTE: The Smart IO requires a minimum supply voltage of 23 volts for terminal 9 (20Vdc) to provide 20 volts.

Power Consumption

Table 3. Power Consumption

Smart IO	Power	
	24Vac	24Vdc
Smart IO	Max. 27VA	Max. 12W

Current Consumption

Table 4. Current Consumption

Smart IO	Power	
	24Vac	24Vdc
Smart IO	Max. 1140mA	Max. 490mA

Operational Environment

Table 5. Operating Environment

Ambient Operating Temperature	-25 to 55 °C (-13 to 131 °F)
Wi-Fi and Bluetooth Operating Temperature	-10 to 55 °C (14 to 131 °F)
Ambient Operating Humidity	5 to 95% relative humidity (non-condensing)
Storage Temperature	-28.9 to +70 °C (-20 to 158 °F)

Table 5. Operating Environment (Continued)

Vibration Under Operation	0.024" double amplitude (2 to 30 Hz), 0.6 g (30 to 300 Hz)
Dust, Vibration	According to EN60730-1
RFI, EMI	Commercial, light, industrial, residential environments
MTBF (Mean Time Between Failure)	11.5 years

Standards

Table 6. Standards

Protection Class	According to final product evaluation, meet requirements of IP20
Product Standards	CAN/CSA-E60730-1:02, Ethernet Protocol version IEEE 802.3, BACnet Standard 135 version 1.14
Testing Electrical Components	IEC68
Certification	<ul style="list-style-type: none"> • UL60730-1 • CSA E60730-1 • UL916 • CSA C22.2 No. 205 • EN 60730-1 • EN 60730-2-9 • FCC Part15, Subpart B • CAN ICES-3 (B)/NMB-3(B) • RoHS II: 2011/65/EU • REACH • Mexico NOM-208-SCFI-2016 • Brazil ANATEL • Chile Resolución Exenta N° 755 de 2005
System Transformer	The system transformer(s) must be safety isolating transformers according to IEC 61558-2-6. In the U.S.A. and Canada, NEC Class 2 transformers must be used.
Mounting compliances	DIN43880 and DIN19

Other Specifications

Table 7. Other Specifications

Real-Time Clock Retention	Buffered for 72 hours by gold capacitor
---------------------------	---

INTERFACES

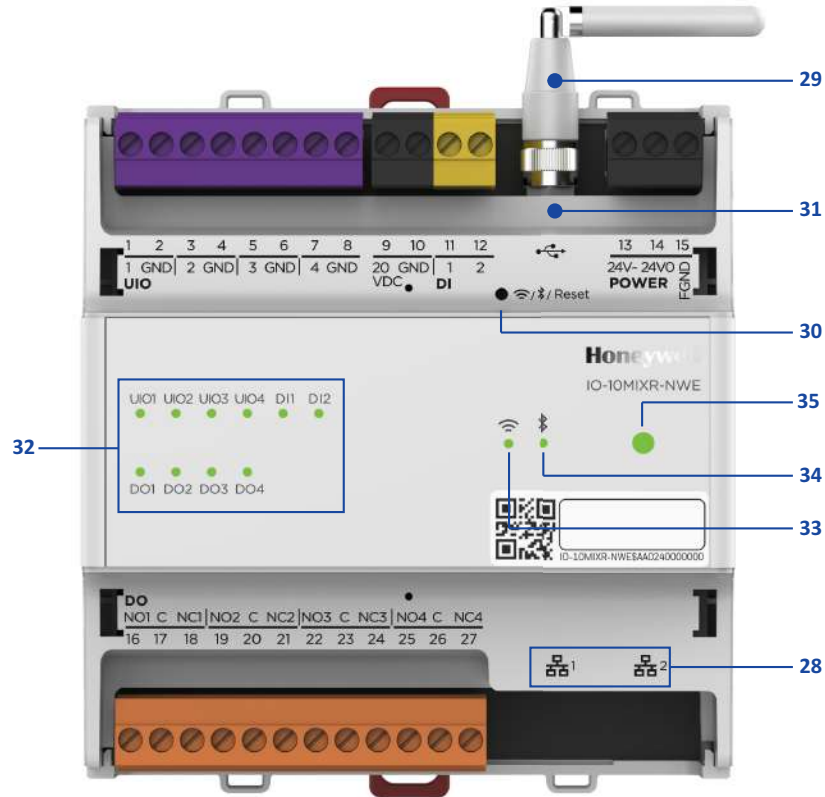

Fig. 1. Smart IO

Table 8. Device Terminals (Continued)

Table 8. Device Terminals

Type	Terminal Number	Signal	Description
UIO 1	1	1	Input/Output signal for UIO 1
	2	GND	Signal ground for UIO 1
UIO 2	3	2	Input/Output signal for UIO 2
	4	GND	Signal ground for UIO 2
UIO 3	5	3	Input/Output signal for UIO 3
	6	GND	Signal ground for UIO 3
UIO 4	7	4	Input/Output signal for UIO 4
	8	GND	Signal ground for UIO 4

Type	Terminal Number	Signal	Description
20VDC Output	9	20V DC	20 Vdc power supply output for active sensors
	10	GND	GND for 20 Vdc and DI
DI	11	1	Digital Input for channel 1
	12	2	Digital Input for channel 2
*POWER	13	24V~	Power supply (for 24V AC, positive terminal for 24V DC)
	14	24V0	Power supply common (for 24V AC, Negative terminal for 24V DC)
	15	FGND	Earth ground in the field

Table 8. Device Terminals (Continued)

Type	Terminal Number	Signal	Description
Change-over Relay 1	16	NO1	Normally Open contact
	17	COM	COM contact for Relay 1
	18	NC1	Normally Closed contact
Change-over Relay 2	19	NO2	Normally Open contact
	20	COM	COM contact for Relay 2
	21	NC2	Normally Closed contact
Change-over Relay 3	22	NO3	Normally Open contact
	23	COM	COM contact for Relay 3
	24	NC3	Normally Closed contact
Change-over Relay 4	25	NO4	Normally Open contact
	26	COM	COM contact for Relay 4
	27	NC4	Normally Closed contact
RJ45 Interface	28	Ethernet 1	10/100 base-T/TX
		Ethernet 2	
SMA Connector	29	Wi-Fi and Bluetooth antenna	Antenna for both Wi-Fi and Bluetooth 802.11a/b/g/n/ac + BT 4.2
Reset/Wireless Button	30	Bluetooth /Factory reset button	Physical button to activate Bluetooth or reset the device to factory default.
USB-C	31		USB-C port to connect with laptops, mobile, and tablets for initial firmware upgrade.

Table 8. Device Terminals (Continued)

Type	Terminal Number	Signal	Description
LED	32	UIO 1	Transmit and receive indication of Universal Input/Output (Off, Green, Yellow, and Red)
		UIO 2	
		UIO 3	
		UIO 4	
		DI 1	Status indication of Digital input (Off, Green, Yellow, and Red)
		DI 2	
		DO 1	Relay status of Digital output (Off and Green)
		DO 2	
	DO 3		
	DO 4		
	33	Wi-Fi	Indicates operational status of the Wi-Fi (Off, Green, Yellow, and Red)
	34	Bluetooth	Indicates operational status of the Bluetooth (Off, Green, Yellow, and Red)
35	Main LED	Indicates the operational status of the Smart IO (Off, Green, Yellow, and Red)	

NOTES:

- Ethernet Ports are for Future Use
- USB-C Port is for Future Use.
- Wi-Fi 5 GHz is for Future Use.
- The GNDs for the UIO and DI are interconnected.
- * Refer to Fig. 2 for AC power supply and Fig. 3 for DC power supply.

WEEE



WEEE Directive 2012/19/EC Waste Electrical and Electronic Equipment Directive

- At the end of the product life, dispose of the packaging and product in an appropriate recycling center.
- Do not dispose of the device with the usual domestic refuse.
- Do not burn the device.

Activating Bluetooth and Resetting the device

The Smart IO has a physical button that provides two functionalities, which are:

- Activating Bluetooth
- Resetting the Smart IO to factory default.

To activate Bluetooth

1. Short press and release the button.
The Bluetooth LED starts blinking, indicates preparing for connection.

The Bluetooth will be disabled automatically after 3 minutes if no connection is available. It will also be disabled after 30 minutes with connection is available but no user activities. However, you can press the button again to enable the Bluetooth.

NOTE: The Wi-Fi is ON while the device is ON and cannot deactivate.

To reset the Smart IO

1. Long press the button (approximately 10 seconds).
All LEDs in the device turn off and the device restarts.

The reset performs the following operations:

- Resets the configuration (BLE PIN Code, WiFi SSID and Password) to default
- Reset to default application
- Reset to default IO characteristics
- Reset to default Offsets
- Keep the current firmware version
- Erase historical data
- Disable Bluetooth

For more details about LED patterns, see “Troubleshooting with LEDs” section on page 21.

Ethernet Interfaces and LEDs

NOTE: Ethernet Ports are for Future Use.

The two Ethernet interfaces 1 and 2 are internally connected to a single Ethernet switch.

Both Ethernet 1 and 2 can connect the Smart IO with laptop/PC using Ethernet crossover cable. The user can upload, download, and debug the Smart IO application using the Honeywell Connect Mobile app or the Supervisor. This connection also establishes the Internet connectivity. They are RJ45 female interfaces, each with a yellow activity status LED (located to the left) and a green activity status LED (located to the right). The possible behaviors and corresponding meanings of these LEDs are explained in the following table.

Table 9. Behavior and meaning of Ethernet Interfaces 1 and 2

LED Status	Behavior	Meaning
Green color LED (at right)	ON	Ethernet is working with connectivity up to 100 Mbps.
	OFF	<ul style="list-style-type: none"> • If yellow color LED is ON or Flashing, then Ethernet is working with connectivity up to 10 Mbps • If yellow color LED is OFF, then Ethernet is disconnected
Yellow color link status LED (at left)	Flashing	Normal operation. The Smart IO is transmitting/receiving data to/from the switch via cable.
	ON	Ethernet connectivity exists but no data flow.
	OFF	No Ethernet connectivity.

Smart IO Inputs/Outputs

Table 10. Smart IO Input/Outputs

UIO (Configured as DI) and DI	<ul style="list-style-type: none"> Pulse inputs capability <ul style="list-style-type: none"> 100Hz max. Minimum duty cycle (50%/50%) = 5ms ON / 5ms OFF Pulse counting with totalizing Dry contact mode <ul style="list-style-type: none"> Closed contact: ≤ 500 ohm. Wetting current: ~ 3.5mA Open contact: $\geq 3k$ ohm. Logic input mode <ul style="list-style-type: none"> Low: 0...2V High: 4...40V
DO Relay	<ul style="list-style-type: none"> 5 amp and 10 amp relays Relay 1: DO1 <ul style="list-style-type: none"> Change over relay. Contact rating (resistive load): 19...250Vac, 10A Max N.O. / 10A Max N.C. 12...30Vdc, 5A Max N.O. / 5A Max N.C. Minimum load: 10mA Relay 2-4: DO2...DO4 <ul style="list-style-type: none"> Change over relays. Contact rating (resistive load): 19...250VAC, 5A Max N.O. / 3A Max N.C. 5...30VDC, 5A Max N.O. / 3A Max N.C. Minimum load: 10mA
UIO (Configured as AI, AO, or DO)	<ul style="list-style-type: none"> Voltage input: 0...10VDC, 2...10VDC Current input: 4...20mA Voltage output: 0...10VDC, 1...10VDC, 2...10VDC, 0...11VDC Current output: 0...20mA, 4...20mA. RTD measurement: Refer to Table 11.
20VDC	<ul style="list-style-type: none"> Current: Max. 100mA Voltage: Min. 18V@100mA

NOTE: The GNDs for the UIO and DI are interconnected.

Supported Sensors

Table 11. Supported Sensors

UIO Mode	Sensor Type
Current Input Externally Powered Mode	<ul style="list-style-type: none"> ALS-300 19.25- 4.25mA 0-300fc ALS-1.5K 19.25-4.25mA 0-1500fc
Voltage Input Mode (Monitoring only)	<ul style="list-style-type: none"> 7330900 (0...100 psig) 7330910 (0...400 psig) RCC-SP150-2 (0...150 psig) RCC-SP150-5 (0...150 psig) RCC-SP150-M (0...150 psig) RCC-SP300-2 (0...300 psig) RCC-SP300-5 (0...300 psig) RCC-SP300-M (0...300 psig) RCC-SP500-2 (0...500 psig) RCC-SP500-5 (0...500 psig) RCC-SP500-M (0...500 psig)
Voltage Input Mode	<ul style="list-style-type: none"> CO2 0-10VDC_0...2000 ppm Pressure 0-10VDC_0...5 in. WC Pressure 0-10VDC_0...2.5 in. WC Pressure 0-10VDC_0...0.25 in. WC RH 0-10VDC (0...100%) RH 2-10VDC (0...100%)
Resistance Input Mode	<ul style="list-style-type: none"> RCC-ST2K-2 (-45.5...+51.7°C) RCC-ST2K-5 (-45.5...+51.7°C) RCC-ST2K-8 (-45.5...+51.7°C) NTC10kΩ (Type 2 and Type 3) (-30...+100°C) NTC20kΩ (-50...+150°C) PT100 (-50...+250°C) PT1000 (-50...+400°C) PT3000 (-50...+150°C) BALCO500 (-40...+150°C) NI1000TK5000 (-30...+130°C) 10K3A1 (-40...+125°C) Nickel Class B DIN 43760 sensors (-60...+169°C) JOHNSON A99 (-40...+120°C)

NOTE: Honeywell sensors were tested and are recommended for use with the Smart IO. Refer to the recommended parts list.

Communication Baud Rates

Table 12. Communication Baud Rates

Ethernet port	10/100 Mbps autobaud
Wi-Fi	802.11b: up to 11Mbps 802.11a/g: up to 54Mbps 802.11n: up to 150Mbps 802.11ac: up to 433Mbps
Bluetooth	Max. 1 Mbps

NOTES:

- Ethernet Ports are for Future Use
- For frequencies, see “Wireless Connectivity” section on page 14.

POWER SUPPLY



WARNING

Risk of electric shock or equipment damage!

Transformers

Honeywell Transformers

A transformer can power the Smart IO. When determining total current consumption and selecting the appropriate transformer, take into account the number of connected modules, accessories, and field devices.

NOTE: In Europe, system transformer(s) must be safety isolating transformers according to IEC61558-2-6. In the U.S.A. and Canada, NEC Class-2 transformers must be used.

Table 13. Honeywell CRT Series Transformers (Europe)

Part No.	Primary Side	Secondary Side
CRT 2	220/230 Vac	24 Vac, 50 VA, 2 A
CRT 6	220/230 Vac	24 Vac, 150 VA, 6 A
CRT 12	220/230 Vac	24 Vac, 300 VA, 12 A

Table 14. Honeywell 1450 Series Transformers (N. America)

Part No. 14507287	Primary Side	Secondary Side
-001	120 Vac	24 Vac, 50 VA
-002	120 Vac	2 x 24 Vac, 40 VA; 100 VA from separate transformer
-003	120 Vac	24 Vac, 100 VA; 24 Vdc; 600 mA
-004	240/220 Vac	24 Vac, 50 VA

Table 14. Honeywell 1450 Series Transformers (N. America)

Part No. 14507287	Primary Side	Secondary Side
-005	240/220 Vac	2 x 24 Vac, 40 VA; 100 VA from separate transformer
-006	240/220 Vac	24 Vac, 100 VA; 24 Vdc, 600 mA

NOTE: Standard commercially available transformers can power the Smart IO.

Switch Mode Power Supply

To reduce overall current consumption, the Smart IO can be powered by a switch mode dc power supply (rather than by a transformer). For Europe, refer to the below table.

Table 15. Recommended Power Supply

Model Number	DCPSU-24-1.3	DCPSU-24-2.5	DCPSU-24-4
Derating input voltage	Max. 1 A (<100 Vac)	Max. 2 A (<100 Vac) 1.8 A (<90 Vac)	Max. 3.5 A (<100 Vac) 3 A (<90 Vac)
Rated input current (nominal load) 110/230 Vac	0.7/0.5 A	1.4/0.6 A	1.6/0.9 A
Internal fuse	2 AT		4 AT
Mains drop compensation at nominal load 110/230 Vac	10/80 ms		18/100 ms
Rated output current	1.3 A <45°C 0.9 A <55°C	2.5 A <45°C 1.75 A <55°C	4 A <45°C 2.8 A <55°C
Efficiency	82% typ.		88% typ.

Fusing

The choice of appropriate fusing is dependent upon the given connection scenario (i.e., cable lengths and the use of a primary and/or secondary transformer) and upon the type of connected bus.

Table 16. Fusing

Designation	Description
F1	4 A, time-lag fuse (slo-blow), e.g., Littlefuse type 218.004.

Example 1: Power Supply and wiring example

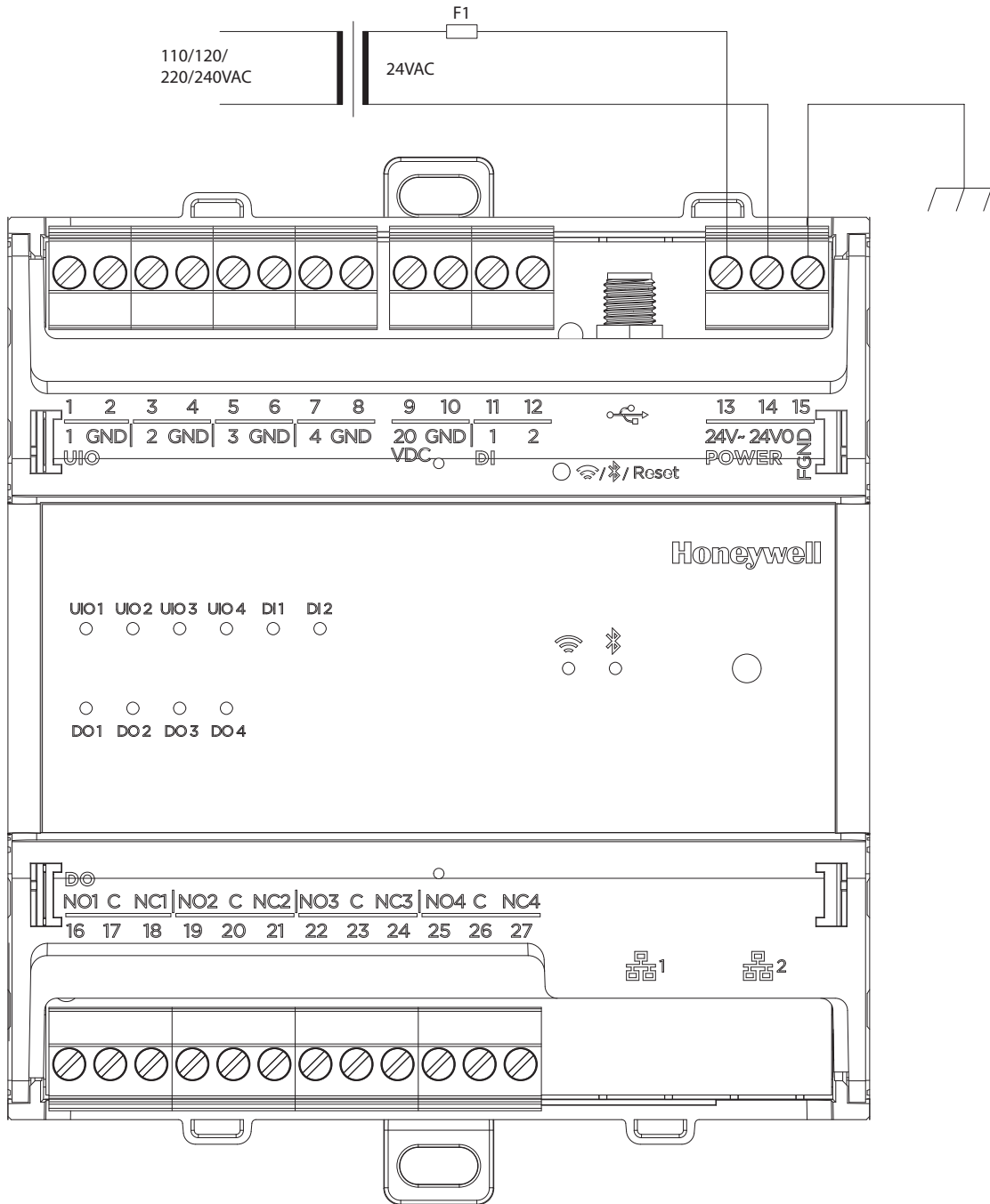

Fig. 2. Power supply Vac

NOTE: When a transformer powers more than one device, the polarity of these devices should be kept the same.

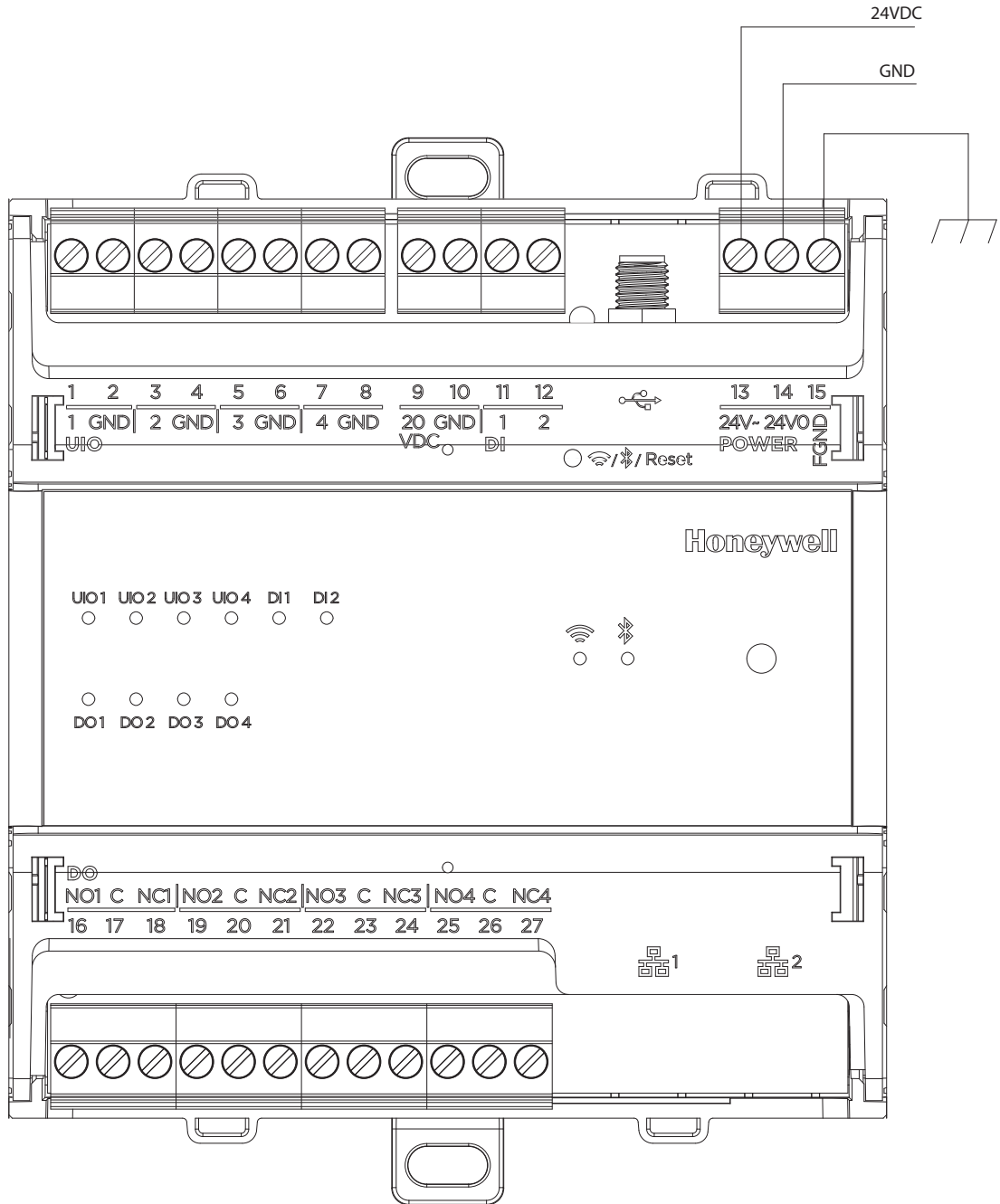

Fig. 3. Power supply Vdc

NOTE: Ensure correct polarity when powered by 24Vdc.

WIRING AND SET-UP

General Safety Considerations

- When connecting the Smart IO, VDE, National Electric Code (NEC) or equivalent, and any local regulations concerning grounding must be observed.
- Only qualified electricians may carry out electrical work.
- The electrical connections must be made at the terminals of the Smart IO.
- For Europe, only: To comply with CE requirements, devices with a voltage in the range of 50 to 1000 Vac or 75 to 1500 Vdc and which are not provided with a supply cord and plug or with other means for disconnection from the supply having a contact separation of at least 3 mm in all poles must have the means for disconnection incorporated in the fixed wiring.
- Only copper conductors should be used for electrical connection.
- Only electrical cables/wires with operating temperature at least 75° C should be used for electrical connection.

WARNING

Risk of electric shock or equipment damage!

- Do not touch any live parts in the cabinet.
- Disconnect the power supply before making connections to or removing connections from Smart IO terminals.
- Do not use spare terminals as wiring support points.
- Do not reconnect the power supply until you have completed the power supply.

CAUTION

Observe the precautions for handling electrostatic devices.

Wiring Terminals

Table 17. Wiring Terminals Specifications

Interface/ Parameter	Power	UIO	DO	DI	20VDC Output
Color	Black	Purple	Orange	Yellow	Black
Number of terminals	1	4	4	1	1
Stripping length	6.5mm				
Torque Value	4.43 lbf.in (0.5Nm)				

Terminals support both flexible and solid cables. Wires can be equipped additionally with ferrules.

Connecting Power Supply

Connect the power supply to the power supply terminals of the Smart IO.

The factory default Smart IO must be powered ON for a minimum of 10 hours for the first time to make the RTC function as intended.

Earth Grounding

The Smart IO comply with SELV (Safety Extra-Low Voltage), so protective earth grounding is not required. However, a functional earth grounding for EMC is mandatory. For information, see “Appendix: Earth Grounding” section on page 26.

Cable Specifications

Power Supply Cable Specifications

The length of the power supply cable includes the length of the cables to connected modules.

Table 18. Power Supply Cable Specifications

Type of signal	Cross-sectional area	
	≤100m Single transformer	≤100m Separate transformers
24V Power	1.5mm ² -2.5mm ² (16AWG-12AWG)	not allowed for > 100 m (300 ft)
High Current Signals - DO Relay version	5A terminal: 1.5mm ² -2.5mm ² (16AWG-12AWG) 10A terminal: 2.5mm ² (14AWG-12AWG)	
Low Current Signals - UIO, DI	0.5mm ² -2.5mm ² (26AWG-12AWG)	
Ethernet	CAT5, CAT6, or CAT7 Ethernet cable, ≤100 m	

NOTES:

- Minimum 23 volts is required for the 20Vdc output.
- Ethernet Ports are for Future Use.
- Copper wire only for the terminal block
- Suggested maximum tighten torque for screw terminal block is 5.0 lb/in or 0.56N/m

WIRELESS CONNECTIVITY

Connectivity Frequency Range

Table 19. Connectivity Frequency Range

Connectivity Medium	Frequency Range	E.I.R.P for CE	E.I.R.P for FCC/IC
Bluetooth	2400 MHz-2483.5 MHz	20 mW	20 mW
Wi-Fi 2.4 GHz	2400 MHz-2483.5 MHz	100 mW	320 mW
Wi-Fi 5 GHz	5150 MHz-5250 MHz	200 mW	100 mW
	5250 MHz-5350 MHz	200 mW	200 mW
	5470 MHz-5725 MHz	200 mW	200 mW
	5725 MHz-5850 MHz	25 mW	100 mW

NOTE: Wi-Fi 5 GHz is for Future Use.

General Information

- The WLAN function for this device is restricted to indoor use only when operating in the 5150 to 5350Mhz Frequency range. Restrictions or Requirements in

	AT	BE	BG	CH	CY	CZ	DE	DK	EE	EL	ES
	FI	FR	HR	HU	IE	IS	IT	LI	LT	LU	LV
	MT	NL	NO	PL	PT	RO	SE	SI	SK	TR	UK

- EMF Statement: To maintain compliance with the RF exposure requirement, a separation distance of 20 cm between the device and the human should be maintained.
- Alarm information in France
 - Déclaration d'exposition Attention: Cet émetteur doit être installé pour fournir une distance de séparation d'au moins 20 cm de toute personne.
 - Le présent appareil est conforme aux CNR d'Industrie Canada applicables aux appareils radio exempts de licence. L'exploitation est autorisée aux deux conditions suivantes: (1) l'appareil ne doit pas produire de brouillage, et (2) l'utilisateur de l'appareil doit accepter tout brouillage radioélectrique subi, même si le brouillage est susceptible d'en compromettre le fonctionnement.
- FCC Warning Statement: "This device complies with Part 15 of the FCC Rules. Operation is subject to the following two conditions:
 - This device may not cause harmful interference, and
 - This device must accept any interference received, including interference that may cause undesired operation.

- Changes or modifications not expressly approved by the party responsible for compliance could void the user's authority to operate the equipment.
- This device complies with FCC radiation exposure limits set forth for an uncontrolled environment.
- This device must not be co-located or operating in conjunction with any other antenna or transmitter.
- End users must follow the specific operating instructions for satisfying RF exposure compliance.
- FCC Class B Statement: NOTE: This equipment has been tested and found to comply with the limits for a Class B digital device, pursuant to part 15 of the FCC Rules. These limits are designed to provide reasonable protection against harmful interference in a residential installation. This equipment generates, uses and can radiate radio frequency energy and, if not installed and used in accordance with the instructions, may cause harmful interference to radio communications. However, there is no guarantee that interference will not occur in a particular installation. If this equipment does cause harmful interference to radio or television reception, which can be determined by turning the equipment off and on, the user is encouraged to try to correct the interference by one or more of the following measures:
 - Reorient or relocate the receiving antenna.
 - Increase the separation between the equipment and receiver.
 - Connect the equipment into an outlet on a circuit different from that to which the receiver is connected.
 - Consult the dealer or an experienced radio/TV technician for help.
- Changes or modifications not expressly approved by the party responsible for compliance could void the user's authority to operate the equipment.
- IC Statement: This device complies with Industry Canada license-exempt RSS standard(s). Operation is subject to the following two conditions: (1) this device may not cause interference, and (2) this device must accept any interference, including interference that may cause undesired operation of the device.
- This device must be professionally installed, this should be noted on grantee.
- To maintain compliance, only the antenna types that have been tested shall be used, which listed in Table 29, "Accessories," on page 27.

RESTRICTIONS IN THE 5 GHZ BAND

Within the 5.15 to 5.25 GHz band, UNII devices will be restricted to indoor operations to reduce any potential for harmful interference to co-channel Mobile Satellite System (MSS) operations.

RESTRICTIONS DANS LA BANDE DE 5 GHZ

Dans la bande de 5,15 à 5,25 GHz, les appareils UNII seront restreints aux opérations intérieures pour réduire toute possibilité d'interférence pouvant nuire aux opérations du Système satellite mobile dans le même canal(MSS).

CONNECTION EXAMPLES

Voltage Input (UIO)/Thermistor Input (UIO)

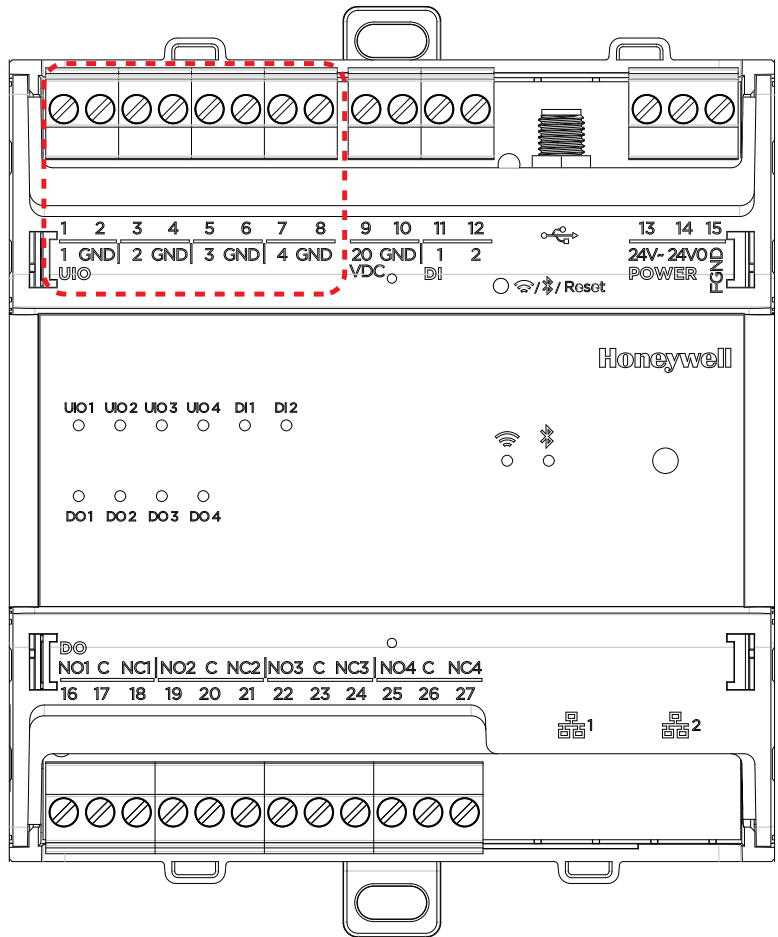

Voltage Input Mode
(0 to 10V)

Ensure correct polarity

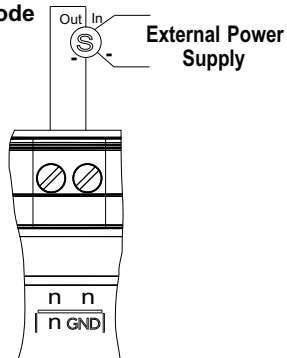

Resistance Input Mode

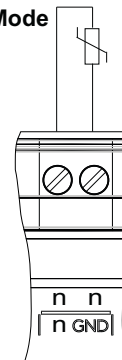

Fig. 4. Voltage Input (UIO)/Thermistor Input (UIO)

NOTE: The GNDs for the UIO and DI are interconnected.

Digital Input (UIO) Connection

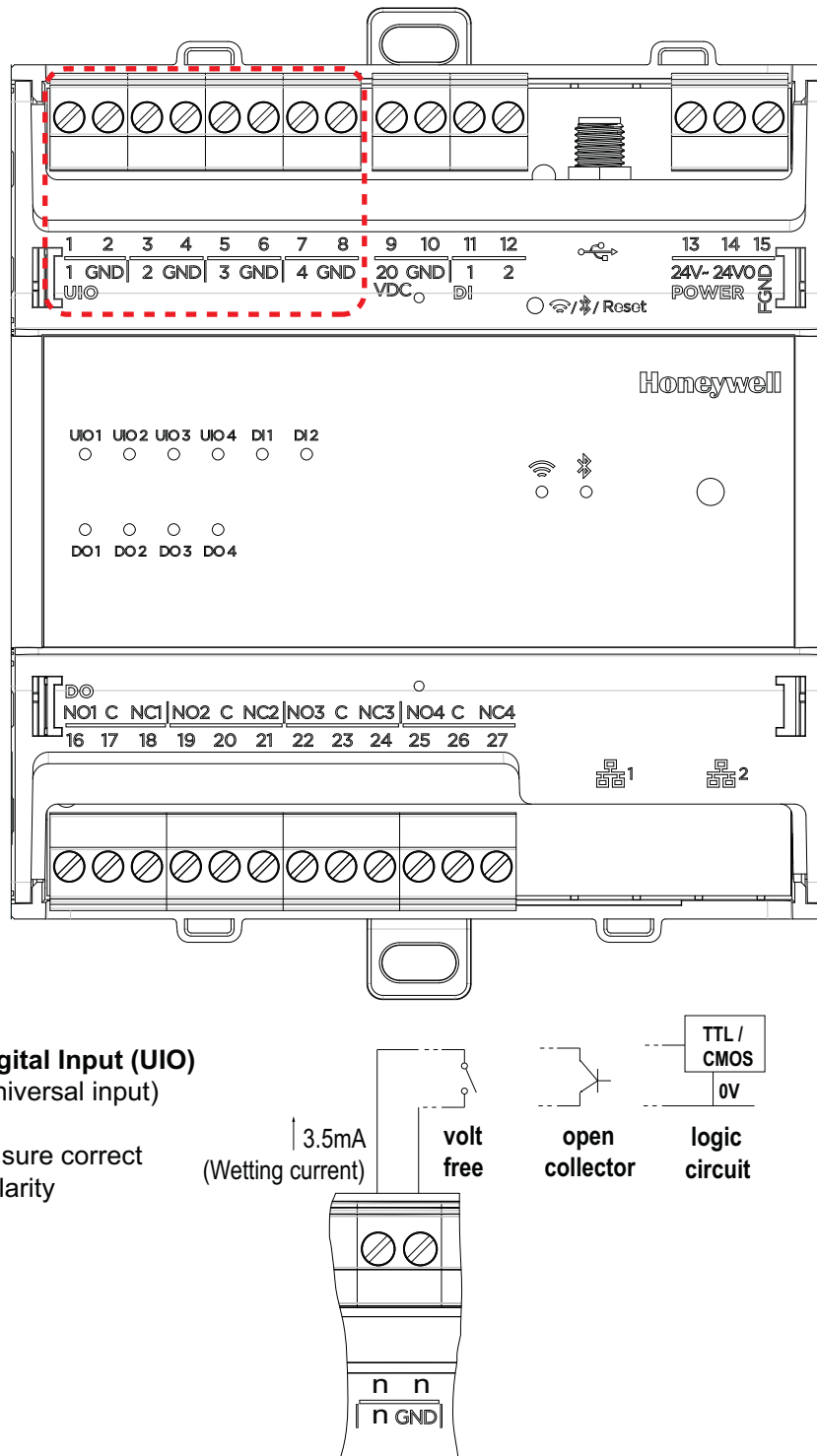
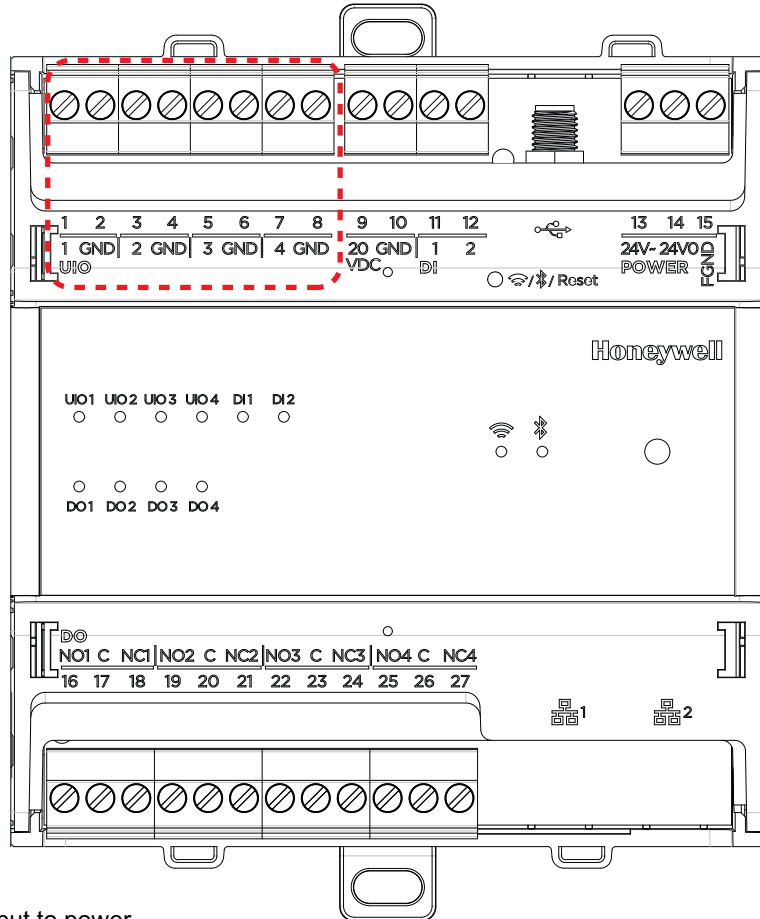

Fig. 5. Digital Input (UIO) Connection

NOTE: The GNDs for the UIO and DI are interconnected.

Binary Output/Analog Output Connection (UIO)



- Voltage output to power external relay
- Protective Diode is recommended to protect the output

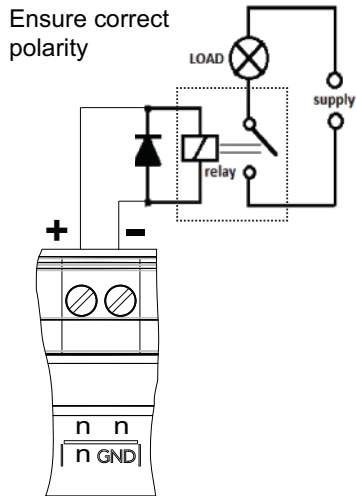

Analog Output (UIO)

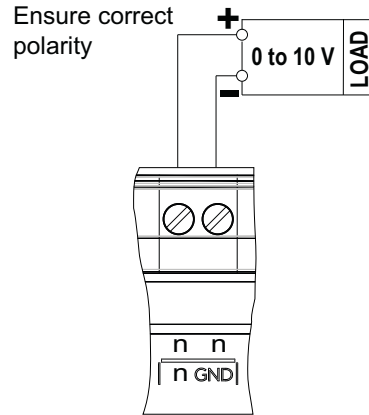

Fig. 6. Binary Output/Analog Output Connection (UIO)

NOTES:

- Analog Output (UIO) provides a variable voltage between 0-10Vdc and the output can source up to 20mA.
- The GNDs for the UIO and DI are interconnected.

Current Input (UIO)/20VDC Output Connection

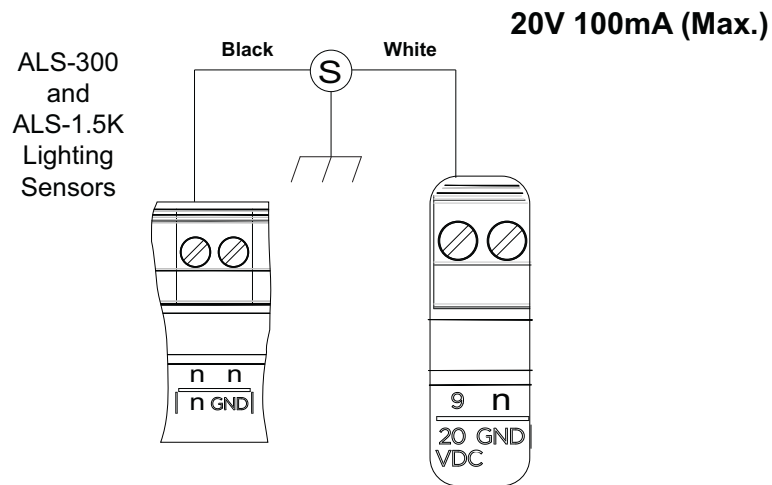
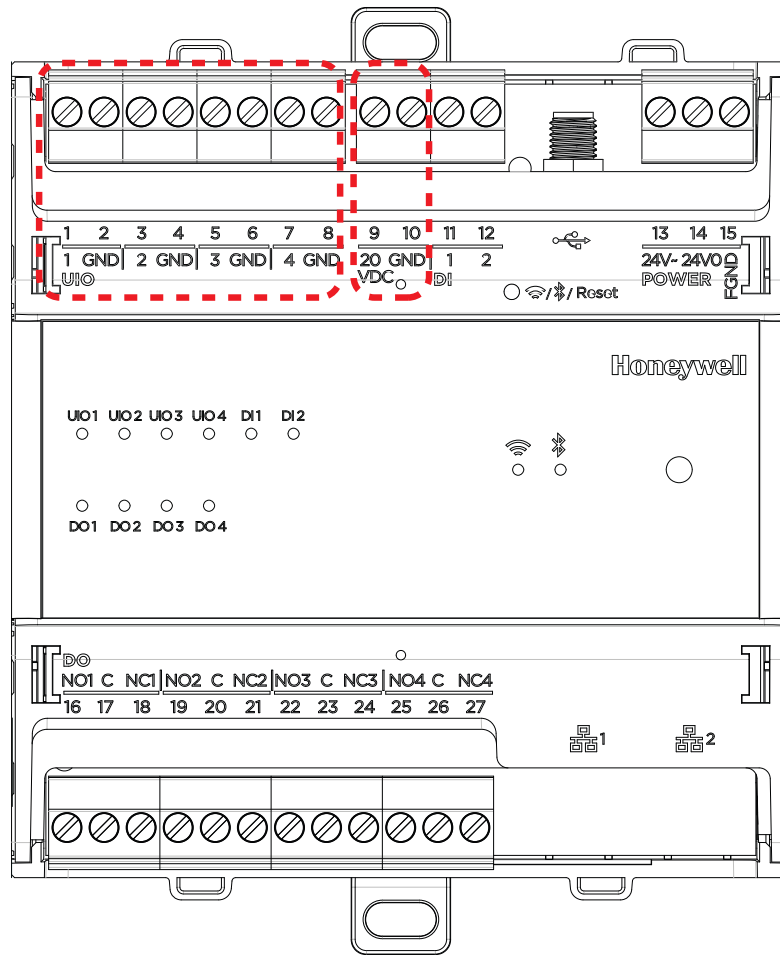
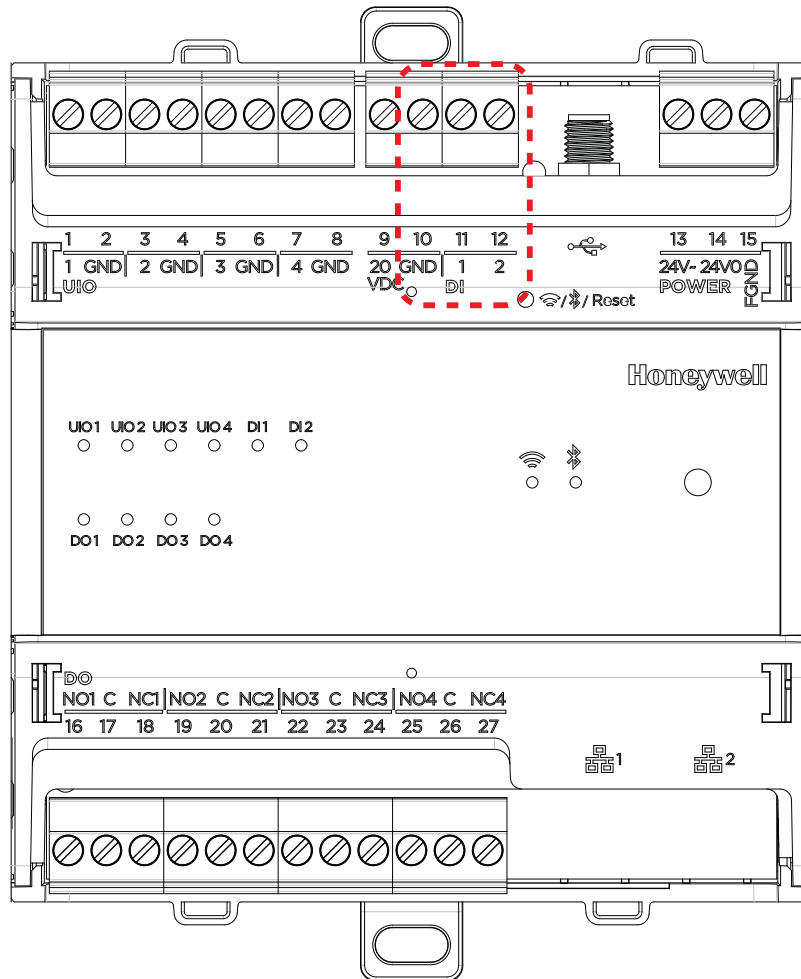

Fig. 7. Current Input (UIO)/20VDC Output Connection

NOTE: The Smart IO requires a minimum supply voltage of 23 volts for terminal 9 (20Vdc) to provide 20 volts.

Digital Inputs Connection



Ensure correct polarity

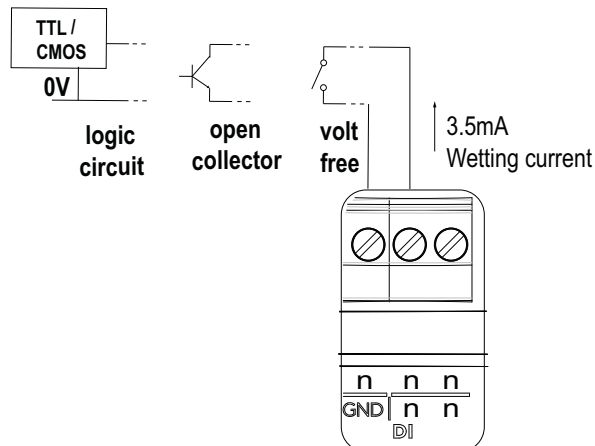

Fig. 8. Digital Inputs Connection

NOTE: The GNDs for the UIO and DI are interconnected.

Digital/Relay Outputs

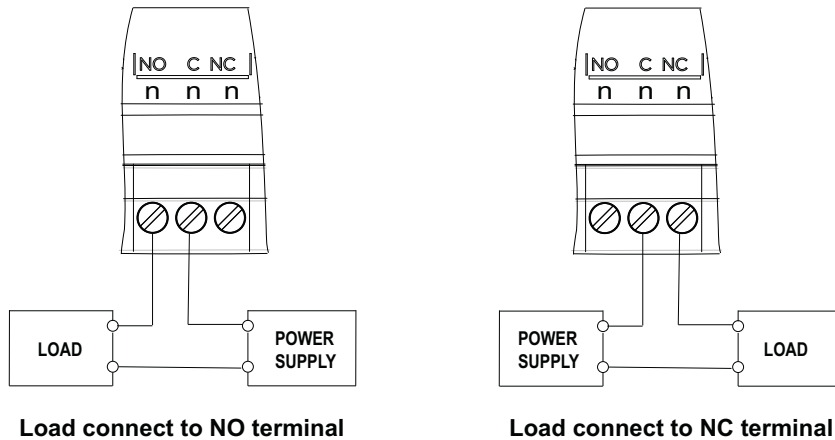
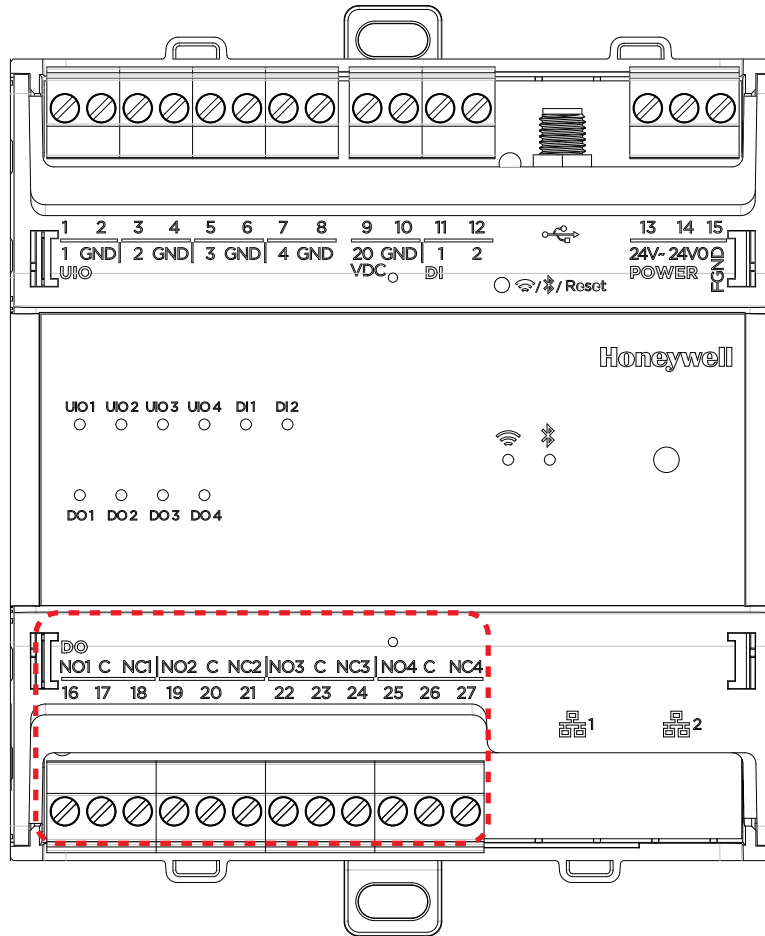
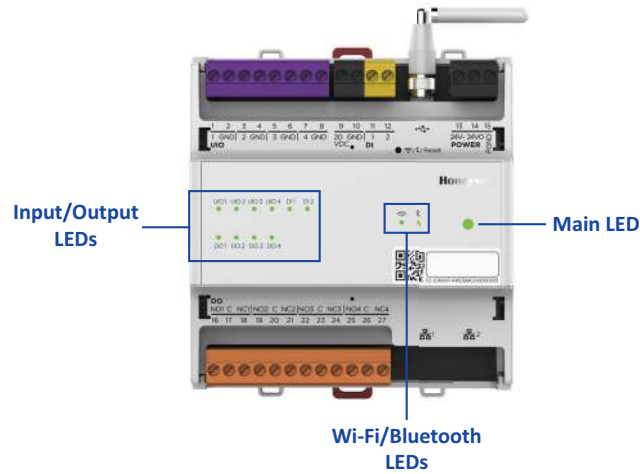

Fig. 9. Digital/Relay Outputs

NOTE: Digital Outputs are changeover relays that provide a single pole Normally Open and Normally Closed contacts. C terminals are standalone and are not connected internally.

TROUBLESHOOTING WITH LEDs



Troubleshooting with Main LED

Table 20. Input/Output LEDs

Case	Main LED Behavior	Meaning
1	LED is off	Power OFF/Power Failure
2	Green-Yellow-Red cycling (Alternate Green, Yellow, Red for every 1 second)	Factory default. Cycling until the device is configured.
3	Solid Green	Power On, the device is configured and working properly.
4	Green blinking every 0.2 seconds	Firmware download or IO configuration in progress
5	Solid Red	Firmware failure (Application no longer runs/lockup of CPU / Watchdog)
6	Solid Yellow	Wi-Fi communication failure
7	Three red blinks in 1.5 second interval and then pause for 2 seconds. (0 0 0 2sec 0 0 0 2sec 0 0 0)	Input failure (any input required by the logic. Eg. AI).

Troubleshooting with Input/Output LEDs

AI Channel

Table 21. AI Channel (Modulating Input) LEDs

Case	AI Channel LED Behavior	Meaning
1	OFF	Unused
2	Solid Green, intensity changes based on input signal (Physical)	Working properly
3	Solid Red (Logical)	Alarm: Out-of-range; sensor break; sensor shorted

DI Channel

Table 22. DI Channel and UIO Channel as Status Input (Binary Input) LEDs

Case	DI Channel LED Behavior	Meaning
1	OFF	OFF = Inactive/Stopped
2	Solid Yellow	On = Active/Running

AO Channel

Table 23. AO Channel (Modulating Output) LEDs

Case	AO Channel LED Behavior	Meaning
1	OFF	Unused
2	Solid Green, intensity changes based on output signal (Physical)	Working properly
3	Solid Red, intensity changes based on output signal.	Alarm: Out-of-range

DO Channel

Table 24. DO Channel LEDs

Case	DO Channel LED Behavior	Meaning
1	OFF	OFF
2	Solid Green	ON

Troubleshooting with Bluetooth LED

Table 25. Bluetooth LED

Case	Bluetooth LED Behavior	Meaning
1	Off	Bluetooth is Off.
2	Solid Green	Bluetooth is connected and working properly.
3	Two green blinks in 1 second interval and then pause for 2 seconds. (O O 2sec O O 2sec O O)	Bluetooth broadcasting mode; Prepared to establish Bluetooth connection with other device.
4	Solid Yellow	Weak signal strength
5	Solid Red	Bluetooth is not functional.

Troubleshooting with Wi-Fi LED

Table 26. Wi-Fi LED

Case	Wi-Fi LED Behavior	Meaning
1	Off	Device is Off.
2	Solid Green	Working properly
3	Two green blinks in 1 second interval and then pause for 2 seconds. (O O 2sec O O 2sec O O)	Prepared to establish Wi-Fi connection with other device.
4	Solid Yellow	Weak signal strength
5	Solid Red	Wi-Fi is not functional.

Troubleshooting with the Ethernet Interface LEDs

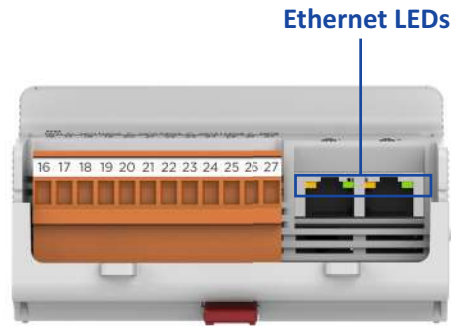

NOTE: Ethernet Ports are for Future Use.

Table 27. Smart IO link and activity LEDs of Ethernet interfaces 1 and 2

Case	LED Behavior	Meaning	Remedy
1	Green color LED is ON steadily	Ethernet is working with connectivity up to 100Mbps.	If communication problems persist, then check yellow color LED. See Case 3 and Case 4 given below.
2	Green color LED is OFF	<ul style="list-style-type: none"> If yellow color LED is ON or flashing, then Ethernet is working with connectivity up to 10Mbps. If yellow color LED is OFF, then Ethernet is disconnected 	Connect the cable between the Smart IO and the switch.
3	Yellow color LED is flashing	Normal operation. The Smart IO is transmitting/receiving data to/from the switch via cable.	If communication problems persist, the Ethernet parameter configuration may be defective: Check IP address, MAC address, and firmware. Refer to associated system documents to check the configuration. For example, Small and Medium Building Administrator Deploy app setup guide (31-00451M).
4	Yellow color LED is ON	Ethernet connectivity exists but no data flow.	Check the software configuration. Refer to associated system documents to check the configuration. For example, Small and Medium Building Administrator Deploy app setup guide (31-00451M).
5	Yellow color LED is OFF	Ethernet port link is down.	<ul style="list-style-type: none"> Check the cable connection between the Smart IO and the switch. Check the switch. Use a good laptop or good cable to directly connect the Smart IO and the switch.

DIMENSIONS

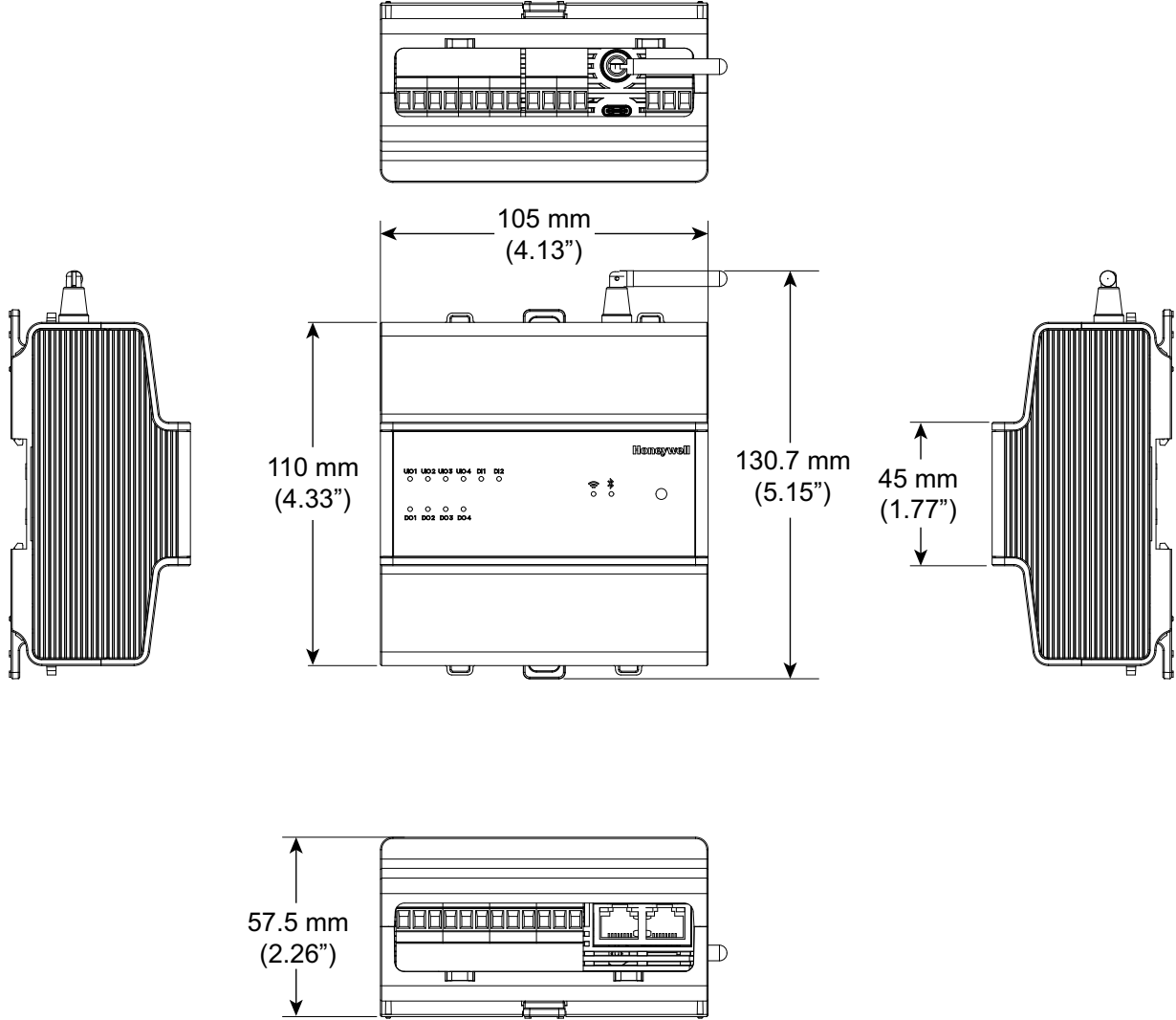

APPENDIX: EARTH GROUNDING

Smart IO and SELV

In order to avoid distribution of noise or earth ground potential differences over networks or other connections, the Smart IO is designed to comply with SELV (Safety Extra Low Voltage).

Furthermore, SELV offers the greatest possible safety against electrical impact.

To support SELV, all Honeywell external (CRT series) or internal transformers comply with standard EN60742. Earth grounding is therefore not recommended.

Smart IO and EN60204-1

However, if compliance with the standard EN60204-1 is required, note the following:

General Information about EN60204-1

EN60204-1 defines electrical safety for a complete application/machine including Smart IOs, sensors, actuators and any connected/controlled electrical device.

EN60204-1 requires Smart IOs to be powered by PELV (Protective Extra-Low Voltage) and earth grounding of the secondary side of the used transformers or earth grounding of the system ground.

Earth grounding is prescribed to prevent the unexpected start-up of connected rotating/moving machines due to an insulation fault and double earth grounding somewhere in the plant.

The use of an earth leakage monitor is also possible to fulfill PELV if earth grounding is prohibited.

When is EN60204-1 Applicable to Smart IO?

SAFETY AGAINST ELECTRICAL IMPACT

EN60204-1 is not mandatory; this is because electrical safety is provided by the use of SELV and transformers according to standard EN60742.

SAFETY AGAINST UNEXPECTED START-UP OF ROTATING/MOVING MACHINES

If the application/plant does not contain machines that can be harmful to the operator due to an unexpected start-up, the standard EN60204-1 is not applicable. If such machines are encountered, then EN60204-1 must be followed. Grounding is required.

Functional EMC Grounding

- Use a cable as short as possible for grounding: min 1.5 mm² (16 AWG).
- For connection details, refer to the following example.

EXAMPLE

Connecting a single transformer with multiple Smart IO Smart IOs earth-grounded as per EN60204-1.

- Connect earth ground to FGND of the Smart IO Smart IOs.

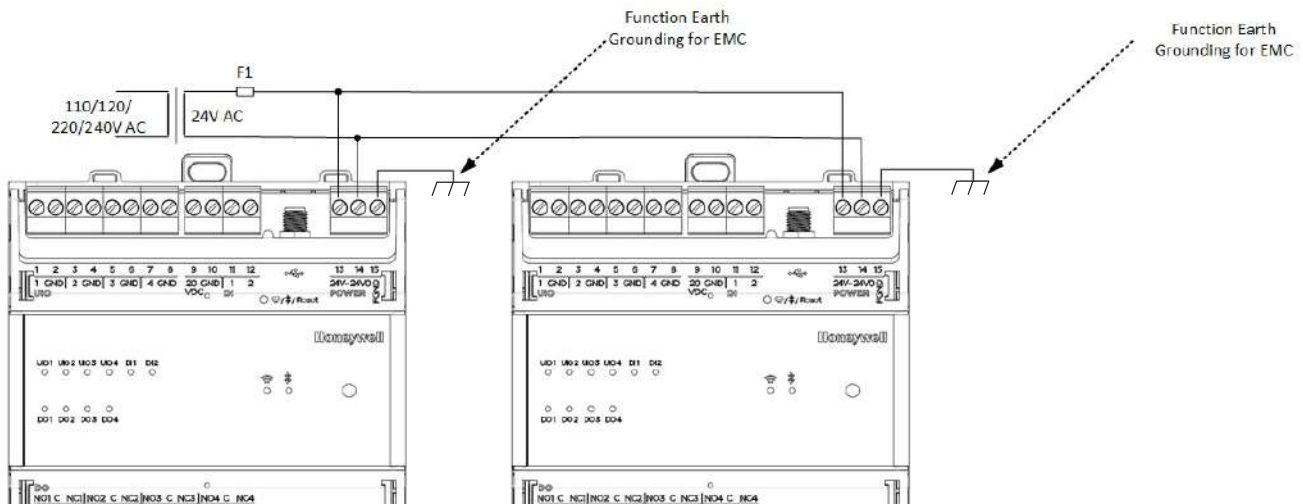

Fig. 10. Connecting and earth grounding multiple Smart IO Smart IOs (single transformer)

NOTES:

- Use a noise-free earth ground inside the cabinet.
- Use one star-point to split power for Smart IOs and field devices.
- If the transformer is used for several Smart IOs, each Smart IO ground has to be wired separately to the star point.
- If a field device that prohibits earth grounding is connected to the system ground, an isolation monitoring device must be used instead of earth grounding.
- If the field device transformer is physically far away from the Smart IO, earth grounding must still be performed for the Smart IO.

SMART IO PART NUMBERS

Table 28. Smart IO

Part Number	Description
IO-10MIXR-NWE	Wireless Smart IO with North American conformance
IO-10MIXR-WE	Wireless Smart IO with European and Latin America conformance

Accessories Part Numbers

These accessories are available by separate order.

Table 29. Accessories

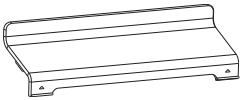
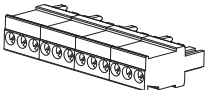
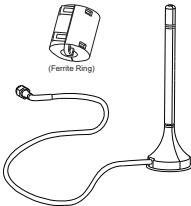
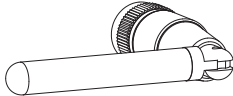
	Part Number	Description
	IO-TCVR-105	Replacement small terminal cover. Fits 105mm IO modules. (Pack of 6)
	IO-10MIXR-STB	Replacement screw terminal blocks for wiring connection. (Pack of 10 Sets)
	ANT-REM	Remote antenna for wireless communication with adhesive and screw mounted base. 1.5 meter (4.9 feet) cable length for remote mounting of the antenna. Includes Ferrite Ring. (Pack of 4)
	IO-ANT-LOC	Local antenna for wireless communication. (Pack of 5)

Remote Antenna Part Numbers

Table 30. Remote Antenna Part Numbers

Part Number	Vendor Name	Type	Gain
CA #ANTT935-4	ADAM	External	2.4 GHz: 2.9dbi 5 GHz: 5.9dbi
GW.05.0113W	TAOGLAS	External	2.4 GHz: 2.57dbi 5 GHz: 1.38dbi

TECHNICAL LITERATURE

Table 31. Technical Literature

Title	Product Literature Number	Contents
IO-10MIXR-WE/IO-10MIXR-NWE Smart IO Datasheet	31-00427	Product data of the device.
IO-10MIXR-WE/IO-10MIXR-NWE Smart IO Mounting Instructions	31-00428	Describes the mechanical mounting of the device.
GW-1000-WE/GW-1000-NWE Gateway Datasheet	31-00424	Product data of the device.
GW-1000-WE/GW-1000-NWE Gateway Installation Instructions	31-00426	Describes electrical connection, configuration, troubleshooting information.
GW-1000-WE/GW-1000-NWE Gateway Mounting Instructions	31-00425	Describes the mechanical mounting of the device.
TC500A-N Commercial Thermostat Datasheet	31-00398M-1	Product data of the device.
TC500A-N Commercial Thermostat Mounting Instructions	31-00399M-1	Describes the mechanical mounting and basic wiring of the device.
TC500A-N Commercial Thermostat User Guide	31-00400M-1	Contains procedures for UI based functionalities of the device.
TC500A-N Commercial Thermostat Quick Start Guide	31-00401M-1	Contains simple procedures to quickly setup the device.
Small and Medium Building Administrator Supervisor User Guide	31-00379M	Contains procedures to control and monitor the Small and Medium Building Administrator devices.
Small and Medium Building Administrator Setup Guide	31-00451M	Contains procedures to commission, monitor, and control the Small and Medium Building Administrator devices.
Small and Medium Building Administrator Security Manual	31-00452M	Contains Honeywell's solution architecture and Cybersecurity related features.
Small and Medium Building Administrator Onboarding User Guide	31-00450M	Admin document. Contains procedures to create new organization and User accounts.

Honeywell Building Solutions

Honeywell
 715 Peachtree Street NE
 Atlanta, GA 30308
customer.honeywell.com
buildingcontrols.honeywell.com

® U.S. Registered Trademark
 © 2020 Honeywell International Inc.
 31-00429 | Rev.10-20

THE
 FUTURE
 IS
 WHAT
 WE
 MAKE IT

Honeywell