

Installation & Operation Manual

11 EER Vertical Wall-Mount Air Conditioners

MODELS:

MAA1018A-MAA1060A, MGA1072A
(Single Stage)

MAA2060A-MGA2072A
(2-Stage)



IMPORTANT

This manual may include information for options and features which may not be included on the unit being installed. Refer to the unit data label or Model Identification to determine which features and options this unit is equipped with.

INSTALLER: Affix the instructions on the inside of the building adjacent to the thermostat.
END USER: Retain this manual for future reference.

Manufactured By:

A Division of the AIRXCEL[®] Commercial Group

P.O. Box 400 • Cordele, Georgia 31010 • 156 Seedling Drive • Cordele, Georgia 31015
(229) 273-3636 • Fax (229) 273-5154

E-mail: marvairsales@airxcel.com • Internet: www.Marvair.com

The most current version of this manual can be found at www.Marvair.com.

How To Use This Manual

This manual is intended to be a guide to the Marvair Wall Mount family of vertical air conditioners. It contains installation, troubleshooting, maintenance, warranty, and application information. The information contained in this manual is to be used by the installer as a guide only. This manual does not supersede or circumvent any applicable national or local codes.

If you are installing the Marvair unit, first read Chapter 1 and scan the entire manual before beginning the installation as described in Chapter 2. Chapter 1 contains general, descriptive information and provides an overview which can speed up the installation process and simplify troubleshooting.

If a malfunction occurs, follow this troubleshooting sequence:

1. Make sure you understand how the Marvair unit works (Chapters 1 & 3).
2. Identify and correct installation errors (Chapter 2).
3. Refer to the troubleshooting information in Chapter 4.

If you are still unable to correct the problem, contact the Factory at 1-800-841-7854 for additional assistance.

Please read the following “Important Safety Precautions” before beginning any work.

Important Safety Precautions

1. USE CARE when LIFTING or TRANSPORTING equipment.
2. TRANSPORT the UNIT UPRIGHT. Laying it down on its side may cause oil to leave the compressor and breakage or damage to other components.
3. TURN ELECTRICAL POWER OFF AT THE breaker or fuse box BEFORE installing or working on the equipment. LINE VOLTAGES ARE HAZARDOUS or LETHAL.
4. OBSERVE and COMPLY with ALL applicable PLUMBING, ELECTRICAL, and BUILDING CODES and ordinances.
5. SERVICE may be performed ONLY by QUALIFIED and EXPERIENCED PERSONS.
 - * Wear safety goggles when servicing the refrigeration circuit
 - * Beware of hot surfaces on refrigerant circuit components
 - * Beware of sharp edges on sheet metal components
 - * Use care when recovering or adding refrigerant
6. Use COMMON SENSE - BE SAFETY-CONSCIOUS

This is the safety alert symbol . When you see this symbol on the Marvair unit and in the instruction manuals be alert to the potential for personal injury. Understand the signal word DANGER, WARNING, CAUTION and IMPORTANT. These words are used to identify levels of the seriousness of the hazard.

 **DANGER** Failure to comply will result in death or severe personal injury and/or property damage.

 **WARNING** Failure to comply could result in death or severe personal injury and/or property damage.

 **CAUTION** Failure to comply could result in minor personal injury and/or property damage.

IMPORTANT Used to point out helpful suggestions that will result in improved installation, reliability or operation.

AS PART OF THE MARVAIR CONTINUOUS IMPROVEMENT PROGRAM, SPECIFICATIONS ARE SUBJECT TO CHANGE WITHOUT NOTICE.

© 02/2021 Marvair, Division of Airxcel, Inc.

 **WARNING**

- If the information in these instructions are not followed exactly, a fire may result causing property damage, personal injury or loss of life.
- Read all instructions carefully prior to beginning the installation. Do not begin installation if you do not understand any of the instructions.
- Improper installation, adjustment, alteration, service or maintenance can cause property damage, personal injury or loss of life.
- Installation and service must be performed by a qualified installer or service agency in accordance with these instructions and in compliance with all codes and requirements of authorities having jurisdiction.

INSTALLER: Affix the instructions on the inside of the building adjacent to the thermostat.

END USER: Retain these instructions for future reference.

Table of Contents

Chapter 1 Marvair Wall Mount Air Conditioner Description & Specifications

1.1	General Description	5
1.2	Model Identification	6
1.3	Serial Number Date Code	7
1.4	Air Flow, Weights and Filter Sizes.....	7
1.5	General Operation	7
1.6	Optional Controls and Packages	8
1.7	Electrical Operation	11
1.8	Economizer Components	17

Chapter 2 Electronic Control Board

2.1	Introduction	21
2.2	Installation and Replacement	22
2.3	Operation.....	22
2.4	Sequence of Operation	26

Chapter 3 Installation

3.1	Equipment Inspection.....	32
3.2	Installation Requirements.....	32
3.3	Installation Materials	34
3.4	Porting and Duct Work	35
3.5	Fresh Air Hood Installation	36
3.6	Bracket Installation	37
3.7	Mounting the Unit	37
3.8	Electrical Connections	38

Chapter 4 Start-Up

4.1	Check-Out of Cooling Cycle	42
4.2	Check-Out of Heating Cycle.....	42

Chapter 5 Troubleshooting

5.1 Overview	43
5.2 Failure Symptoms Guide.....	44
5.3 Compressor Troubleshooting	44
5.4 Control Board Diagnosis.....	45

Chapter 6 Maintenance

6.1 Scheduled Maintenance	46
---------------------------------	----

Chapter 7 Warranty

7.1 Airxcel Commercial Group Limited Product Warranty	47
---	----

Chapter 8 Start-Up Checklist

8.1 Start-Up & Commissioning Form.....	48
--	----

Appendix A

Installation Instructions for Field Installed Electric Heaters	52
--	----

Illustrations

Figure 1a. Typical Electrical Schematic - Model MAA.....	12
Figure 1b. Typical Electrical Schematic - Model MAA.....	13
Figure 1c. Typical Electrical Schematic - Model MAA (Alternate Construction).....	14
Figure 1d. Typical Electrical Schematic - Model MAA (Alternate Construction).....	15
Figure 1e. Typical Electrical Schematic - Model MGA (Alternate Construction).....	16
Figure 2. Dry Bulb sensor.....	18
Figure 3. Enthalpy Sensor Temperature Control Points	19
Figure 4. Electrical Controls, HVESA Alternate Construction	19
Figure 5. Economizer Control Board	20
Figure 6a. Setting the Speed for the Y1 and Y2 Operation for Indoor Motor	23
Figure 6b. Second Stage Cooling Speed	23
Figure 7. Output Termination for Indoor Motor Control Signal	24
Figure 8. Outdoor Motor Speed Setting	24
Figure 9. Output Termination for Outdoor Motor Control Signal.....	24
Figure 10. Communications SetUp	25
Figure 11. Fresh Air Hood Damper, Models 1024-1072.....	36
Figure 12. Wall Mounting Detail.....	37
Figure 13a. Humidistat Wiring Details.....	40
Figure 13b. Thermostat Connection Diagram	40
Figure 13c. CommStat™ 3 HVAC Controller Wiring Detail.....	41

Tables

Table 1 CFM @ External Static Pressure	7
Table 2 Return Air Filter Sizes	7
Table 3 Installed Unit Weights.....	7
Table 4 Ambient Temperature Operating Range	7
Table 5 Refrigerant Charge.....	8
Table 6. MODBUS Network Address DIP Switch Positions	26
Table 7a. MODBUS Discrete Registers	30
Table 7b. MODBUS Registers.....	31
Table 8 Minimum Clearances	33
Table 9 Voltage Limitations	33
Table 10 Maximum Static Pressure	36

Chapter 1 Description & Specifications

1.1 General Description

The Marvair MAA and MGA are a series of vertical wall-mounted air conditioning systems that provide heating, cooling, and ventilation for electronic equipment shelters, process control centers, and other applications with high internal heat gains. The series includes multiple sizes and nominal cooling capacities from 18,000 to 72,000 BTUH. Resistance heating elements are available in various wattages.

MAA models are available with cooling capacities of 18,000 to 60,000 BTUH and EER's of 11.00 to 11.50. MGA models have 72,000 BTUH (6 ton) capacity and are 10 EER. The Marvair Product Data Sheets have detailed information on the capacities and efficiencies for each model.

See Appendix A for instructions on field installation of electric heat.

Marvair air conditioners feature an exclusive electronic control board. The control board consolidates several of the electrical components and improves the air conditioner's reliability. The control board replaces the blower relay, the lockout relay, the compressor time delay and the timed low pressure bypass. In addition, the control board has LED's to indicate operating status and fault conditions to assist the service technician. A complete description of functions of the control board is in Section 1.6.

All models are designed for easy installation and service. Major components are accessible for service beneath external panels.

All units have internal disconnects (optional on 380V and 575V). Follow local codes for external disconnect requirements.

Marvair wall mount air conditioners have a 0-15% manual outside air damper as standard equipment. All models are available with an optional factory installed economizer for 100% free cooling with outside air.

1.2 Model Identification

The model identification number is found on the data sticker. Rating plate located on side panel.

Example	M	A	A	1	0	3	6	A	D	0	5	0	C	+	+	+	+	1	E	A	+	A	2	1	+	+	+	+	+	+
Position	1	2	3	4	5	6	7	8	9	10	11	12	13	14	15	16	17	18	19	20	21	22	23	24	25	26	27	28	29	30

1	Unit Designation/Family	M = Marvair Wall Mount
2	Energy Efficiency Ratio (EER)	A = 11 G = 10
3	Refrigerant Type	A = R-410a
4	Compressor Type/Quantity	1 = Single
5	Unit Capacity/Nominal Cooling (BTUH)	018 = 18,000 042 = 42,000
6		020 = 20,000 048 = 48,000
7		024 = 24,000 060 = 60,000 030 = 30,000 072 = 72,000 036 = 36,000
8	System Type	A = Air Conditioner
9	Power Supply (Volts-Phase-Hz)	A = 208/230-1-60 D = 460-3-60 C = 208/230-3-60 Z = 575-3-60
10	Heat Designation @ Rated Voltage	000 = No Heat 080 = 8KW
11		022 = 2.2KW 090 = 9KW
12		036 = 3.6KW 100 = 10KW 040 = 4KW 120 = 12KW 050 = 5KW 150 = 15KW 060 = 6KW
13	Ventilation Configuration	A = Solid Front Door C = Economizer D = Motorized Damper w/Pressure Relief E = Motorized Damper w/Pressure Relief & Independent Motorized Damper Control F = No Free Cooling, 100% Emergency Ventilation Only w/Independent Control N = Barometric Damper w/15% OSA Y = Manual Damper w/No Pressure Relief Z = Manual Damper w/Pressure Relief + = None \$ = Special
14	Dehumidification	G = Hot Gas Reheat R = Electric Reheat T = Electric Reheat w/Humidity Control + = None \$ = Special
15	Controls	A = Power Fail Alarm w/Additional Lockouts C = 24V EMS Relay Kit D = 24V EMS Relay Kit w/Factory Installed T-Stat E = Factory Installed T-Stat + = None \$ = Special
16	Operating Condition	A = Evaporator Freeze Sensor (EFS) C = EFS w/Hot Gas Bypass D = Desert Duty E = Extreme Duty F = Desert Duty w/Hard Start G = Desert Duty w/EFS H = Desert Duty w/Hard Start & EFS J = Extreme Duty w/Hard Start K = Extreme Duty w/EFS M = Extreme Duty w/Hard Start & EFS N = Hard Start P = Hard Start w/Low Ambient & CCH Q = Hard Start w/Low Ambient & Fan Cycle Control (FCC) R = Crank Case Heater (CCH) T = Hard Start w/EFS U = Hard Start w/Hot Gas Bypass V = Hard Start w/Low Ambient & CCH & EFS W = Low Ambient w/CCH X = Hot Gas Bypass Y = Low Ambient w/CCH & FCC Z = Low Ambient w/CCH & EFS 1 = Low Ambient w/FCC 2 = Low Ambient w/FCC & EFS 3 = CCH w/Hot Gas Bypass + = None \$ = Special

17	Indoor Air Quality Features	D = Dry Bulb Sensor E = Dry Bulb Sensor w/Dirty Filter G = Dirty Filter Sensor + = None \$ = Special
18	Air Flow	1 = Top Supply/Bottom Return 2 = Center Supply (Reverse) 3 = Bottom Supply/Top Return (Counter) 4 = Top Panel Discharge 5 = Centrifugal Blowers 6 = 3T3 7 = 3T5 8 = 4T2 9 = 4T3 A = 3T2 \$ = Special
19	Compressor Location	C = Center - All 6 ton units and above D = Left Hand - All 3 1/2 to 5 ton units E = Right Hand - All 1 1/2 to 3 ton units
20	Filter Option	A = 2" Pleated (MERV 8, AC/HP-C) C = 2" Charcoal D = MERV 11 High Filtration Package E = MERV 13 High Filtration Package F = Filter Access Through Return Air Grille W = Aluminum Washable + = None \$ = Special
21	Corrosion Protection	A = Condenser Coil Only C = Evaporator Coil Only D = Both Coils Condenser & Evaporator E = All Coils Cond/Evap/Reheat F = Coat All G = Coastal Package & Evaporator Coil K = Coastal Package + = None \$ = Special
22	Engineering Revision	A1
23	Level	A2 B2
24	Cabinet Color	1 = Marvair Beige 2 = Gray 3 = Carlsbad Canyon 4 = White 5 = Stainless Steel Exterior 6 = Dark Bronze 7 = .050 Aluminum Stucco 8 = Mesa Tan 9 = Pebble Gray A = Stainless Steel - Unit \$ = Custom Color (Powder Coat)
25	Sound Attenuation	2 = Compressor Blanket + = None
26	Security Option	A = Lockable Access Plate/Tamper Proof C = Tamper Proof Screws D = Lockable Access Plate w/Tamper Proof + = None \$ = Special
27	Fastener/Drain Pan Option	A = Stainless Steel Fasteners C = Stainless Steel Drain Pan D = Stainless Steel Fasteners & Drain Pan + = None \$ = Special
28	Unused	+ = None \$ = Special
29	Unused	+ = None \$ = Special
30	Special Variation	+ = None \$ = Special Configuration Not Covered by Model Nomenclature

Note: Not all options are available with all configurations. Contact your Marvair sales representative for configuration details and feature compatibility.

1.3 Serial Number Date Code

20 = 2020	01 = January	05 = May	09 = September
21 = 2021	02 = February	06 = June	10 = October
22 = 2022	03 = March	07 = July	11 = November
23 = 2023	04 = April	08 = August	12 = December

1.4 Air Flow, Weights and Filter Sizes

Complete electrical and performance specifications and dimensional drawings are in the Marvair Wall Mount Air Conditioner Product Data Sheets.

Note: Follow local codes and standards when designing duct runs to deliver the required airflow. Minimize noise and excessive pressure drops caused by duct aspect ratio changes, bends, dampers and outlet grilles in duct runs.

Model	0.10	0.15	0.20	0.25	0.30	0.40	0.50
MAA1018	685	670	670	642	640	600	
MAA1020	800	785	770	725	680	600	
MAA1024	800	785	770	725	680	600	500
MAA1030	1200	1150	1100	1050	1000	900	800
MAA1036	1290	1230	1170	1115	1060	1000	920
MAA1042	1500	1430	1360	1295	1230	1160	1070
MAA1048	1950	1900	1850	1815	1760	1680	1590
MAA1060	1900	1850	1800	1700	1600	1500	1350
MGA1072	1900	1850	1800	1700	1600	1500	1350

Values in bold are the minimum air flow.
Air flow ratings of 208-230 volt units are at 230v. Air flow ratings of 460 volt units are at 460 volts. Operation of units at a voltage different from the rating point will affect air flow.

Table 1. CFM @ External Static Pressure (Wet Coil) (IWG)

Model	INCHES	MILLIMETERS	PART NUMBER	FILTERS PER UNIT	MERV RATING
MAA1018	14 x 12 1	356 x 305 x 25	P/80122	1	N/A
MAA1020/1024	16 x 25 x 2	406 x 635 x 51	80137	1	8
MAA1024/1030/1036 "B2" INTERNAL	16 x 30 x 1	406 x 762 x 25	80136	1	N/A
MAA1024 "B2" RETURN GRILLE	11½ x 19½ x 1	292 x 495 x 25	91983	1	N/A
MAA1030/1036	18 x 30 x 2	457 x 762 x 51	93184	1	8
MAA1030/1036 "B2" RETURN GRILLE	27½ x 13½ x 1	699 x 343 x 25	80769	1	N/A
MAA1042/1048	36½ x 22 x 2	927 x 559 x 51	80162	1	8
MAA1060	18 x 24 x 2	457 x 610 x 51	81257	2	8
MGA1072	18 x 24 x 2	457 x 610 x 51	81257	2	8

Table 2. Return Air Filter Sizes

Model	Weight	Base	w/Economizer	w/3 Phase	w/Economizer & 3 Phase
MAA1018	Pounds (Kilograms)	265 (120)	N/A	N/A	N/A
MAA1020/MAA1024	Pounds (Kilograms)	337 (153)	357 (162)	356 (161)	376 (171)
MAA1024/1030 "B2"	Pounds (Kilograms)	378 (171)	400 (181)	397 (180)	419 (190)
MAA1030/MAA1036	Pounds (Kilograms)	397 (180)	419 (190)	416 (189)	438 (199)
MAA1036 "B2"	Pounds (Kilograms)	380 (172)	403 (183)	418 (190)	441 (200)
MAA1042/MAA1048	Pounds (Kilograms)	453 (205)	476 (216)	491 (223)	514 (233)
MAA1060	Pounds (Kilograms)	469 (213)	492 (223)	522 (237)	545 (247)
MGA1072	Pounds (Kilograms)	571 (259)	594 (269)	624 (283)	647 (293)

Table 3. Installed Weights for Marvair Wall Mount AC Units

1.5 General Operation

Model	Ventilation Configuration	Temperature Range
Non-Economizer	Standard ("N")	20°F – 131°F (-7°C – 55°C)
	Desert Duty ("ND")	20°F – 131°F (-0°C – 55°C)
	Extreme Duty ("NE"), 60 Hz Only	0°F – 131°F (-18°C – 55°C)
With Economizer	Standard ("CE")	-40°F – 131°F (-40°C – 55°C)
	Desert Duty ("CD")	-40°F – 131°F (-40°C – 55°C)
	Extreme Duty ("CE"), 60 Hz Only	-40°F – 131°F (-40°C – 55°C)

Table 4. Ambient Temperature Operating Range

Model	MAA1018A	MAA1020A	MAA1024A	MAA1024-1030A "B2"	MAA1030A	MAA1036A & "B2"	MAA1042A	MAA1048A	MAA1060A	MGA1072A	
	A	A	A C D Z	A	A C D Z	A C D Z	A C D Z	A C D Z	A C D Z	A C D Z	A C D Z
w/o Hot Gas Reheat	65	85	85	110	90	105	123	128	125	150	160
w/Hot Gas Reheat	N/A	N/A	N/A	N/A	N/A	N/A	N/A	N/A	N/A	N/A	N/A

Table 5. Refrigerant Charge (R410A, Ounces)

Refrigerant Cycle (Cooling Mode)

Marvair air conditioners use R-410A refrigerant in a conventional vapor-compression refrigeration cycle to transfer heat from air in an enclosed space to the outside. A double blower assembly blows indoor air across the evaporator. Cold liquid refrigerant passing through the evaporator is boiled into gas by heat removed from the air. The warmed refrigerant gas enters the compressor where its temperature and pressure are increased. The hot refrigerant gas condenses to liquid as heat is transferred to outdoor air drawn across the condenser by the condenser fan. Liquid refrigerant is metered into the evaporator to repeat the cycle.

Heating Mode

A wall-mounted thermostat controls the heating cycle of models which incorporate resistance heating elements. On a call for heat, the thermostat closes the heat relay to energize the indoor fan and the resistance elements. Except on units with the optional dehumidification kit, the compressor is locked out during the heating cycle. Please see Appendix A for instructions on field installing electric heaters.

Economizer Operation

The economizer is a regulated damper system with controls. The damper regulates the circulation of outside air into the enclosure (when the outdoor air conditions are suitable) to reduce the need for mechanical cooling, save energy, and extend compressor life.

Depending upon the options selected, the damper responds to the enthalpy of the outdoor air. On a call for cooling from a space thermostat, it operates as follows:

When the enthalpy of the outdoor air is below the set point, the outdoor air damper is proportionally open (and return air damper is proportionally closed) to maintain between 50°F and 56°F (10°C to 13°C) at the mixed/discharge air sensor. Integral pressure relief allows the indoor air to exit the shelter through the air conditioner.

When the enthalpy of the outdoor air is above the set point, the outdoor air damper closes to its minimum position. A call for cooling from the space thermostat brings on mechanical cooling.

A built-in adjustable minimum position potentiometer controls the amount of outdoor air admitted to meet minimum ventilation requirements.

1.6 Optional Controls & Packages

Hard Start Kit

Used on single phase equipment to give the compressor higher starting torque under low voltage conditions. Generally not recommended on units with scroll compressors.

Extreme Duty Package

The Extreme Duty Package allows selected Marvair air conditioners to operate in extremely cold and hot ambient conditions. The Extreme Duty Kit is always factory installed. Non-economizer air conditioners will operate from 0° F to 131° F (-18° to 55°C). Economizer equipped air conditioners will operate from -40° F to 131° F (-40° to 55°C).

The Extreme Duty Package includes a suction line accumulator, thermal expansion valve (TXV), crankcase heater, hard start kit, an auto reset, high pressure switch and an outdoor thermostat and fan cycle switch. The fan cycle control is standard on all Marvair air conditioners and operates based upon the liquid line

pressure. The outside thermostat closes whenever the outside temperature is below 50°F (10°C) and opens when the outside temperature is 50° F (10°C) or higher. Whenever the temperature is below 50°F (10°C), the fan cycle switch is in the circuit; when temperatures are 50° F (10°C) or higher, the fan cycle switch is not in the circuit. The fan cycle control is used with a TXV to prevent excessive cycling or "hunting" of the TXV.

Protective Coating Packages

Typically only the non-economizer units are used in corrosive environments, but the air conditioners with an economizer is also available with corrosion protection. Two corrosion protection packages are offered- one for the condenser section (the Coastal Environmental package) and the other for the entire unit (the Coat-All Package).

The Coastal Environmental Package includes:

- Corrosion resistant fasteners
- Sealed or partially sealed condenser fan motor
- Protective coating applied to all exposed internal copper and metal in the condenser section
- Protective coating on the condenser coil (Luvata Insitu®) contains ES2 (embedded stainless steel pigment) technology.

The Coat all Package includes all of the above, plus:

- Protective coating on the evaporator coil (Luvata Insitu®) contains ES2 (embedded stainless steel pigment) technology
- Protective coating on exterior and interior components and sheet metal. (Note: the internal sheet metal which is insulated, bottom outside panel, and the internal control box are not coated)

Hot Gas Bypass (Non-Economizer Models Only)

Used in specialty applications; i.e., Magnetic Resonance Imaging (MRI) buildings, to prevent magnetic voltage disturbance caused by compressor cycling. Two hot gas bypass option packages are available to allow operation to 20°F (-7°C) or minus 20°F (-29°C). Please refer to Hot Gas Bypass Application Bulletin for details.

Electric Reheat Dehumidification

A humidity controller allows electric heat and cooling to operate simultaneously. Marvair® air conditioners equipped with the dehumidification option allow the indoor humidity of the controlled environment to be maintained at or below a certain humidity set point. These units do not have the ability to add humidity to the building.

IMPORTANT

The electrical wire and breaker or fuses must be sized for simultaneous operation of the electric heater and the air conditioner. Refer to the data sticker on the unit or the appropriate Air Conditioner Product Data Sheet for the sizing information.

Dehumidification is achieved by operating mechanical cooling in conjunction with electric reheat. The strip heat is sized approximately to the sensible capacity of the total tonnage of the machine (i.e., on a 24,000 BTU unit the strip heat is sized at approximately 20,000 BTU). Because the strip heat is sized to the approximate sensible cooling capacity, only selected models are available.

Operation:

When the humidity rises above the set point on the humidity controller both mechanical cooling and electric reheat operate to temper the air and lower the humidity. If the temperature in the controlled environment rises above the set point of the thermostat and the unit is operating in the dehumidification mode, the call for cooling will override the call for dehumidification and the strip heat is disengaged until the thermostat is satisfied. This assures the environment temperature is maintained as first priority and humidity control is second.

In applications where a shelter has redundant air conditioning units and is controlled by a lead lag controller (CommStat Touch, CommStat 4, CommStat 3 HVAC Controller), most times the dehumidification option is only necessary on one of the two units. It is possible for one unit to be operating in the cooling mode while the unit with dehumidification is operating at the same time. If the cooling unit does not maintain the shelter temperature set point, the unit with dehumidification will go into the cooling mode. It does not matter whether the unit with dehumidification is the lead or lag unit.

Three Phase Voltage Monitor

Continuously measures the voltage of each of the three phases. The monitor separately senses low and high voltage, voltage unbalance including phase loss and phase reversal. An LED indicator glows when all voltages are acceptable. Automatically resets when voltages and phases are within operating tolerances. Not required on 1Ø units.

Dirty Filter Indicator

A diaphragm type of indicator measures the air pressure on either side of the filter and when the pressure drops below the set point, a red LED is illuminated. The set point is adjustable.

Protective Coil Coatings

Either the condenser or evaporator coil can be coated, however, coating of the evaporator coil is not common. For harsh conditions, e.g., power plants, paper mills or sites where the unit will be exposed to salt water, the condenser coil should be coated. Note: Cooling capacity may be reduced by up to 5% on units with coated coils.

Thermal Expansion Valve

Available on all Marvair air conditioners. Improves performance in hot ambient temperatures.

High Filtration

Selected units are built with larger blowers/motors for use with higher efficiency filters with MERV ratings of 11, 13 and 14 when tested to ASHRAE 52.2. Units with economizers have a pre-filter on the outside air.

Lockable Disconnect Access Cover Plate

The access plate to the service disconnect switch can be equipped with a lockable cover.

Cold Climate Kit

Controls and components which allow the units to operate in extremely cold temperatures. The kit includes a suction line accumulator, thermal expansion valve (TXV), crankcase heater, hard start kit, and an outdoor thermostat and fan cycle switch. The fan cycle control is standard on all Marvair air conditioners and operates based upon the liquid line pressure. The outdoor thermostat opens whenever the outside temperature is below 50°F (10°C) and closes when the outside temperature is 50°F (10°C) or higher. Whenever the temperature is below 50°F (10°C), the fan cycle switch is in the circuit; when temperatures are 50°F (10°C) or higher, the fan cycle switch is not in the circuit. The outdoor thermostat is used with a TXV to prevent excessive cycling or “hunting” of the TXV.

Desert Duty

The Desert Duty package is a factory installed package of components and cabinet modifications which permit operation in harsh environments. To prevent sand and dust infiltration, the electrical control box is sealed. A closed loop design on non-economizer units insures that no outside air is introduced into the shelter. Note: Units with an economizer may be ordered with the Desert Duty Package. If the air conditioner is required with the Desert Duty Package, sand intrusion into the shelter should be considered. Units without an economizer will operate from 20°F to 131°F (-7°C to 55°C). Economizer equipped units will operate from -40°F to 131°F (-29°C to 55°C).

Cabinet Color and Material

Marvair air conditioners are available in three different cabinet colors -the standard Marvair beige, white and gray. The standard cabinet's sides, top and front panels are constructed of 20 gauge painted steel. As an option, these panels can be built of 16 gauge steel in beige & gray or .050 stucco aluminum. When the 16 gauge painted steel or the aluminum is used, only the side, top and front panels are 16 gauge or aluminum. Contact your Marvair representative for color chips. The cabinet can also be constructed of type 316 stainless steel. Two stainless steel cabinet constructions are available- the complete cabinet, including most internal sheet metal or only the exterior sheet metal

1.7 Electrical Operation

The compressor and condenser fan are energized with a contactor controlled by a 24 VAC pilot signal.

Some compressors incorporate an internal PTC crankcase heater that functions as long as primary power is available. The heater drives liquid refrigerant from the crankcase and prevents loss of lubrication caused by oil dilution. Power must be applied to the unit for 24 hours before starting the compressor.

The condenser (outside fan) motor is energized by the same contactor. However, the motor is cycled on and off by the low ambient control (see low ambient control 1.6).

The indoor evaporator fan motor is controlled by the fan purge on the electronic control board.

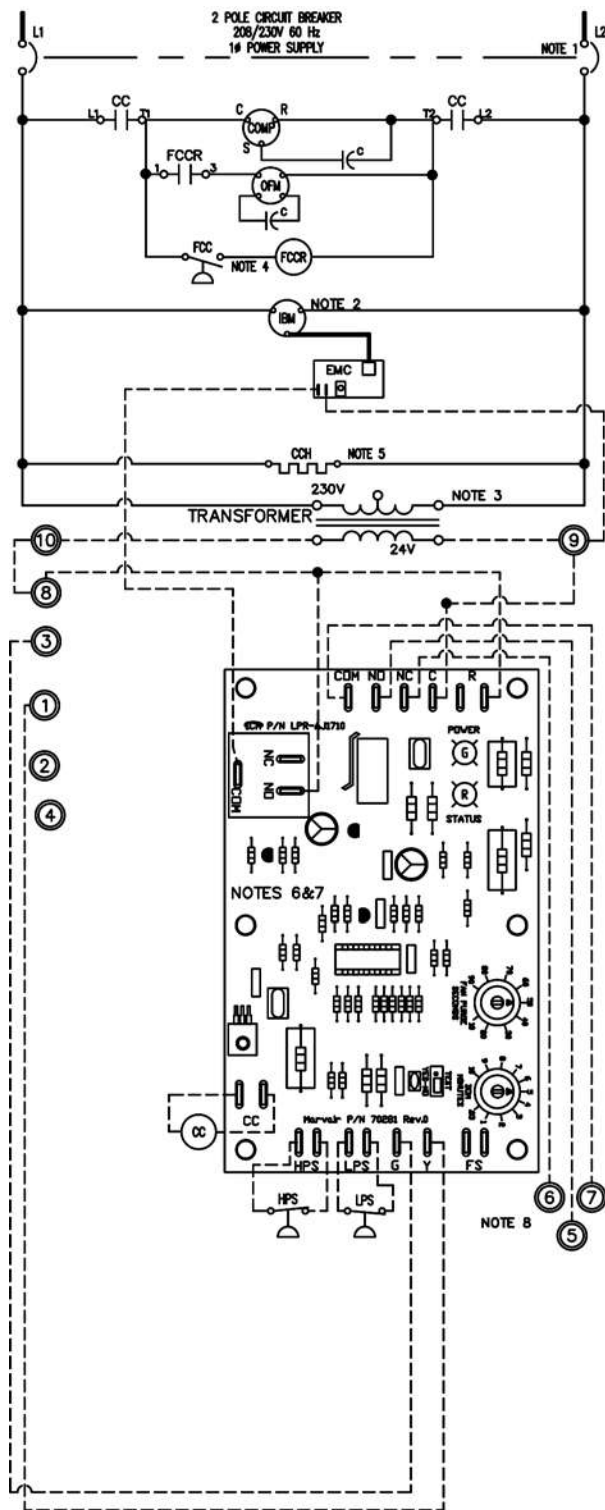

ELECTRICAL LEGEND:

C	CAPACITOR	LPS	LOW PRESSURE SWITCH
CC	COMPRESSOR CONTACTOR	OFM	OUTDOOR FAN MOTOR
CCH	CRANKCASE HEATER	PCB	PRINTED CIRCUIT BOARD
COMP	COMPRESSOR	XFMR	TRANSFORMER
EMC	ELECTRONIC MOTOR CONTROL		
FCC	FAN CYCLE CONTROL		
FCCR	FAN CYCLE CONTROL RELAY		
HPS	HIGH PRESSURE SWITCH		
IBM	INDOOR BLOWER MOTOR		

VOLTAGE LEGEND

—————	LINE VOLTAGE FACTORY
—————	LINE VOLTAGE FIELD
-----	LOW VOLTAGE FACTORY
-----	LOW VOLTAGE FIELD
-----	ALT. VOLTAGE (FIELD SPEC.)

COLOR CODE

BK	- BLACK	O	- ORANGE
BL	- BLUE	R	- RED
BR	- BROWN	Y	- YELLOW
G	- GREEN	WHT	- WHITE
BK/RED	- BLACK, RED STRIPE		

GENERAL NOTES:

- 208/230 VOLT 60 Hz 1φ POWER SUPPLY. SEE DATA PLATE FOR AMPACITY & FUSE SIZE. OPTIONAL CKT BKR SHOWN.
- FACTORY PROGRAMMED ECM MOTOR.
- TRANSFORMER IS FACTORY WIRED FOR 230 VOLT OPERATION. FOR LOWER VOLTAGES, INTERCHANGE ORANGE AND RED LEADS. INSULATE UNUSED LEADS.
- ALTERNATE DEVICE IS NOT ADJUSTABLE AND HAS ORANGE LEADS.
- CRANKCASE HEATER MAY NOT BE REQUIRED ON ALL COMPRESSORS.
- COMPRESSOR TIME DELAY AND FAN PURGE DELAY ARE LOCATED ON THE PCB (PRINTED CIRCUIT BOARD) AND ARE ADJUSTABLE.
- THE (STATUS LED) WILL BLINK ONE TIME AFTER THE HPS (HIGH PRESSURE SWITCH) HAS OPENED TWICE AND THE UNIT WILL LOCKOUT. THE (STATUS LED) WILL BLINK TWICE AFTER THE LPS (LOW PRESSURE SWITCH) HAS OPENED TWICE AND THE UNIT WILL LOCKOUT.
- THE LOCKOUT CIRCUIT CONTACTS ARE N.O. BETWEEN TERMINALS 5 AND 7 OF THE LOW VOLTAGE TERMINAL BOARD AND N.C. BETWEEN TERMINALS 7 AND 6 OF THE LOW VOLTAGE TERMINAL BOARD.

Figure 1a. Typical Electrical Schematic - (Non-Economizer) Model MAA

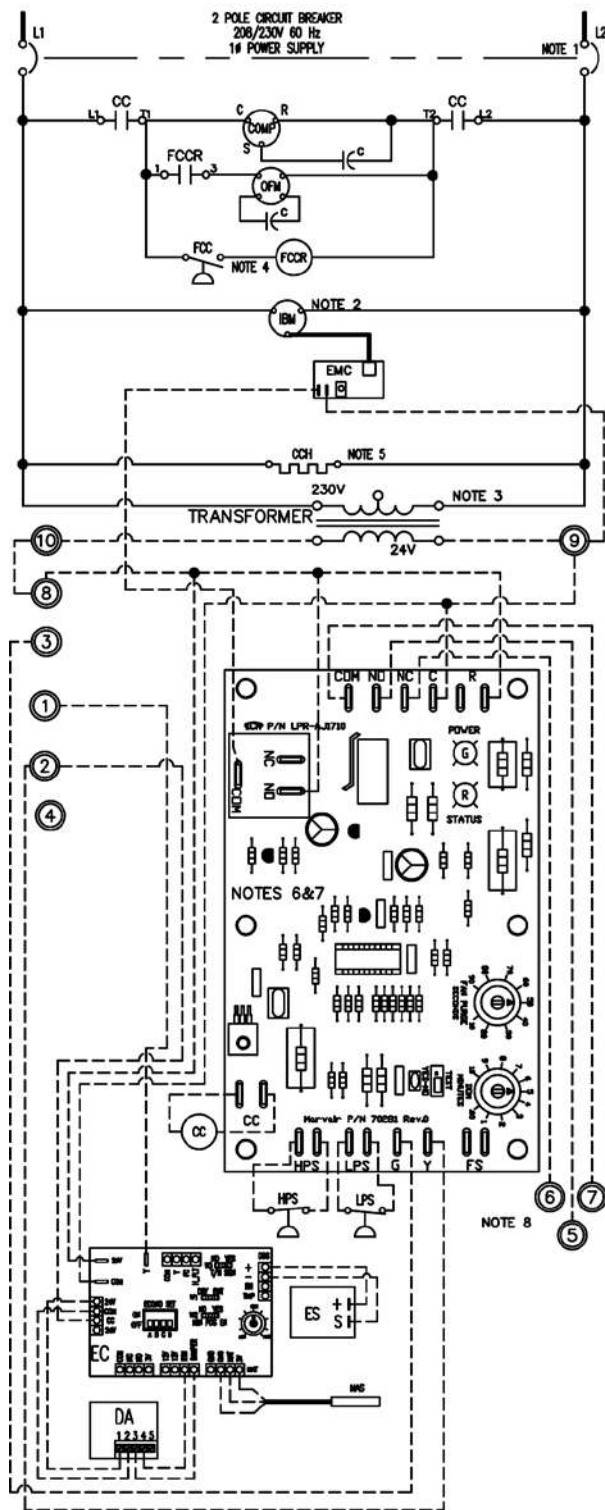

ELECTRICAL LEGEND:

C	CAPACITOR	LPS	LOW PRESSURE SWITCH
CC	COMPRESSOR CONTACTOR	MAS	MIXED AIR SENSOR
CCH	CRANKCASE HEATER	OFM	OUTDOOR FAN MOTOR
COMP	COMPRESSOR	PCB	PRINTED CIRCUIT BOARD
DA	DAMPER ACTUATOR	XFMR	TRANSFORMER
EC	ECONOMIZER CONTROLLER		
EMC	ELECTRONIC MOTOR CONTROL		
ES	ENTHALPY SENSOR		
FCC	FAN CYCLE CONTROL		
FCCR	FAN CYCLE CONTROL RELAY		
HPS	HIGH PRESSURE SWITCH		
IBM	INDOOR BLOWER MOTOR		

VOLTAGE LEGEND

—————	LINE VOLTAGE FACTORY
—————	LINE VOLTAGE FIELD
-----	LOW VOLTAGE FACTORY
-----	LOW VOLTAGE FIELD
-----	ALT. VOLTAGE (FIELD SPEC.)

COLOR CODE

BK - BLACK	O - ORANGE
BL - BLUE	R - RED
BR - BROWN	Y - YELLOW
G - GREEN	WHT - WHITE
BK/RED - BLACK, RED STRIPE	

GENERAL NOTES:

- 208/230 VOLT 60 Hz 1Φ POWER SUPPLY. SEE DATA PLATE FOR AMPACITY & FUSE SIZE. OPTIONAL CKT BKR SHOWN.
- FACTORY PROGRAMMED ECM MOTOR.
- TRANSFORMER IS FACTORY WIRED FOR 230 VOLT OPERATION. FOR LOWER VOLTAGES, INTERCHANGE ORANGE AND RED LEADS. INSULATE UNUSED LEADS.
- ALTERNATE DEVICE IS NOT ADJUSTABLE AND HAS ORANGE LEADS.
- CRANKCASE HEATER MAY NOT BE REQUIRED ON ALL COMPRESSORS.
- COMPRESSOR TIME DELAY AND FAN PURGE DELAY ARE LOCATED ON THE PCB (PRINTED CIRCUIT BOARD) AND ARE ADJUSTABLE.
- THE (STATUS LED) WILL BLINK ONE TIME AFTER THE HPS (HIGH PRESSURE SWITCH) HAS OPENED TWICE AND THE UNIT WILL LOCKOUT. THE (STATUS LED) WILL BLINK TWICE AFTER THE LPS (LOW PRESSURE SWITCH) HAS OPENED TWICE AND THE UNIT WILL LOCKOUT.
- THE LOCKOUT CIRCUIT CONTACTS ARE N.O. BETWEEN TERMINALS 5 AND 7 OF THE LOW VOLTAGE TERMINAL BOARD AND N.C. BETWEEN TERMINALS 7 AND 6 OF THE LOW VOLTAGE TERMINAL BOARD.

Figure 1b. Typical Electrical Schematic - (Economizer) Model MAA

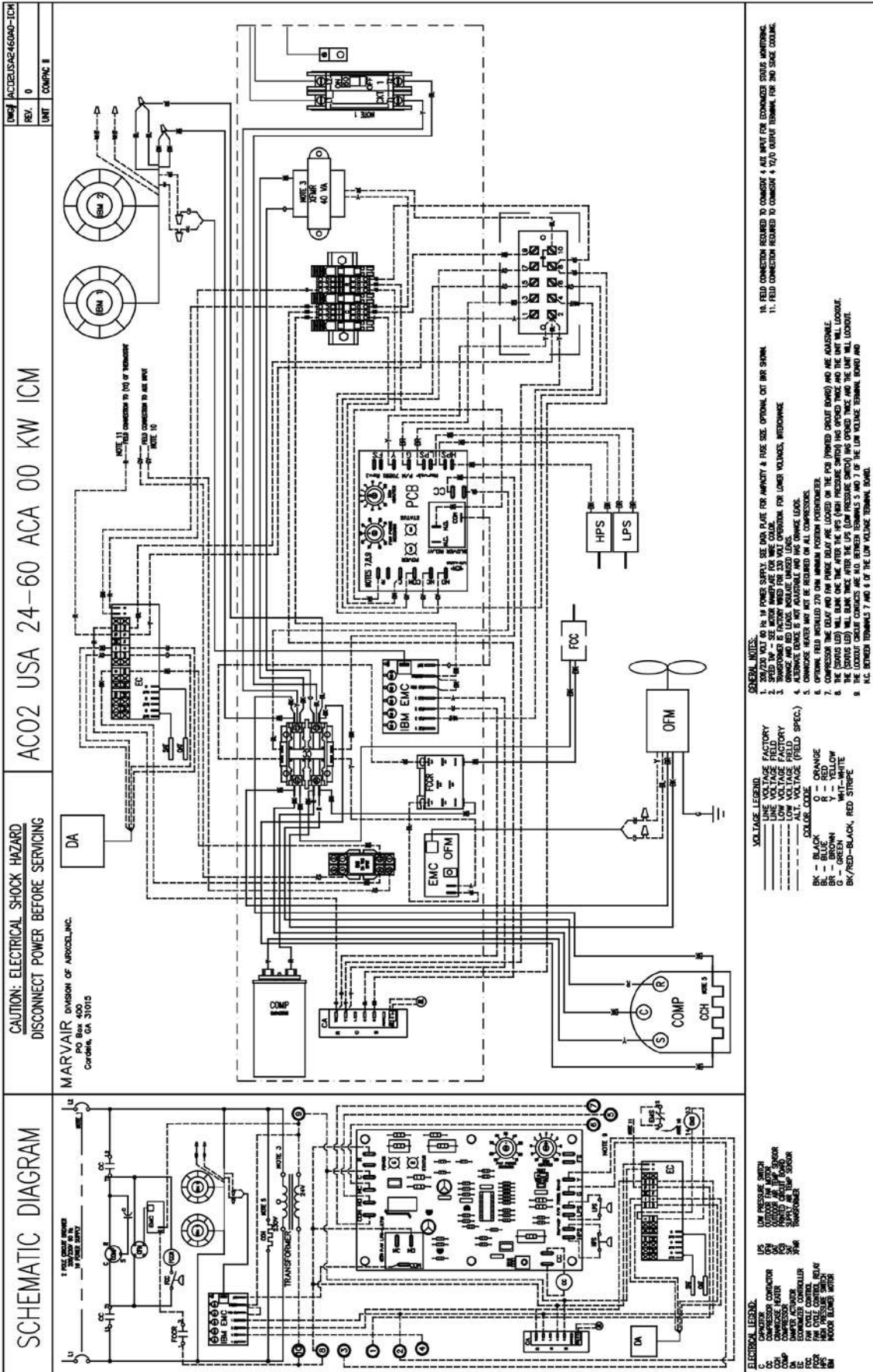

Figure 1c. Typical Electrical Schematic - (Economizer) Model MAA (Alternate Construction)

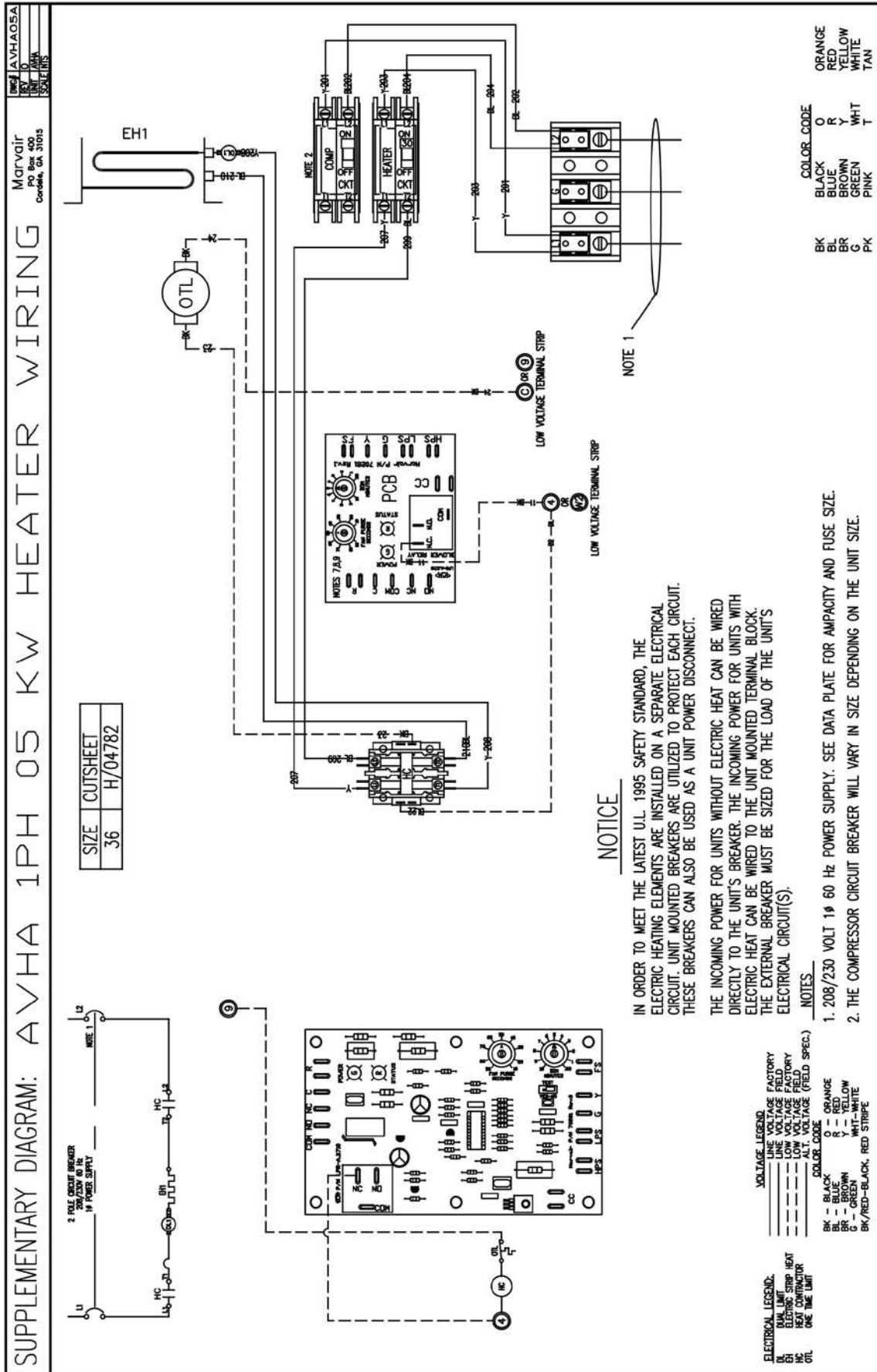

Figure 1d. Typical Electrical Schematic - (Economizer) Model MAA (Alternate Construction)

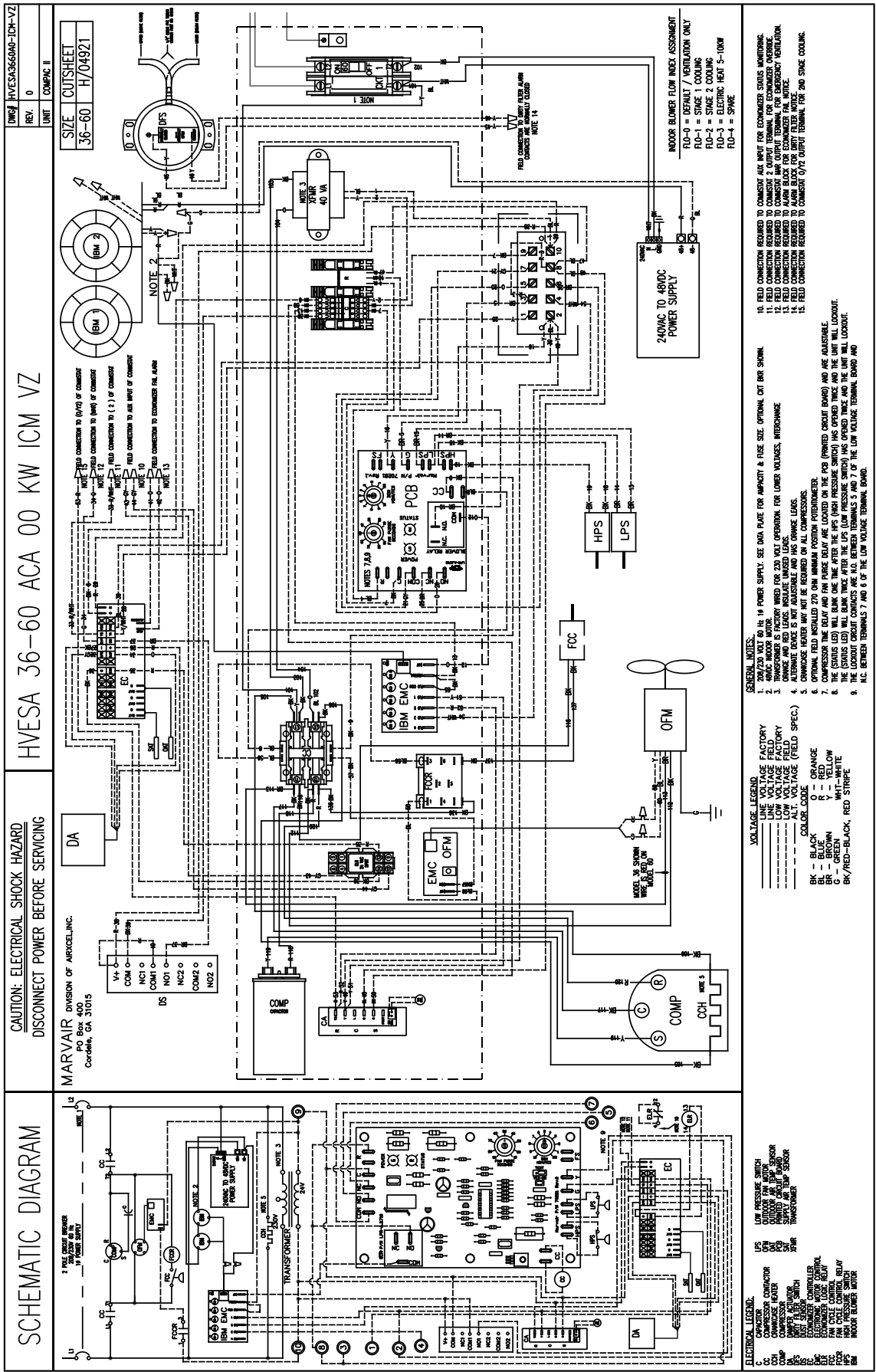

Figure 1e. Typical Electrical Schematic - (Economizer), Model MGA (Alternate Construction)

1.8 Economizer Components (Economizer Equipped Models Only)

Damper Actuator:

The damper actuator is a 24V motor that modulates the position of the damper blade. It is capable of driving a full 90 degrees within 90 seconds. The assembly has a spring return to close the damper during power outage.

Economizer changeover control (W1 Jumper)

The economizer can be controlled by either an enthalpy sensor or a dry bulb sensor. On a call for cooling from the wall-mounted thermostat, if outdoor conditions are suitable, the sensor will open the damper and admit outside air (i.e., economizer free cooling). If the outdoor ambient is too hot or humid (enthalpy sensor only), the sensor will place the actuator in the closed or minimum open position and activate mechanical cooling. The compressor is locked-out during the economizer cooling mode.

During the testing of the air conditioner at the factory, the control board has been configured for the sensor in the air conditioner. There should be no need to change the sensor configuration. If an enthalpy sensor is being used, pins 1 & 2 should be jumpered on the board. If a dry bulb sensor is being used, pins 2 & 3 should be jumpered. See item 1 in Figure 4 for the location of this jumper.

Economizer changeover control setting - Enthalpy Sensor

The enthalpy sensor responds to the total heat content of the outdoor air to provide the changeover to outside air for free cooling. The control board must be configured for proper operation of the economizer by selecting the desired changeover temperature. The desired temperature is selected by four dip switches on the board. See item 9 in Figure 4 for the location of the dip switches.

1. Selecting the set point for the enthalpy sensor. On the board there are four dip switches – 1, 2, 3 & 4 - that determine the ambient temperature at which the economizer damper opens. These dip switches correspond to the following temperatures:

DIP Switch #	Previous Honeywell controller setting	Temperature °F/°C
All 4 Switches Down	A	73°/23.8°C
1	A	73°/23.8°C
2	B	70°F/21.1°C
3	C	67°F/19.4°C
4	D	63°F/17.2°C

2. Gently push the dip switch UP to select the desired set point temperature. The factory setting is for dip switches number 1, 2, & 3 to be in the Down position and #4 to be in the Up position. With dip switch #4 in the Up position, the economizer damper will begin to open when the ambient temperature is 63°F/17.2°C.
3. Only one switch should be in the Up position.

Note: having all four switches in the down position is the same setting as having the #1 switch in the Up position.



Sever hazard. The economizer contains moving parts capable of causing serious injury or death. Disconnect power before removing the covering panel.

Economizer changeover control – Dry Bulb Sensor

The dry bulb sensor only responds to the dry bulb temperature of the outside air and ignores the humidity. The sensor has eight set points. The factory setting is 58°F (14.5°C). These set points can be changed by moving the dip switches on the top of the dry bulb sensor. See Fig. 2.



Figure 2. Dry Bulb Sensor

Once either the enthalpy or dry bulb sensor has determined that the outside air is suitable for cooling, the damper will open. The mixed air sensor will limit the air temperature delivered to the space by modulating the damper blade to mix warm indoor air with cooler outdoor air to provide a constant 50°F to 56°F (10°C to 13.5°C)

Mixed Air Sensor:

The mixed air sensor is a thermistor mounted on a bracket adjacent to the right side of the blower assembly. The thermistor senses the air temperature entering the structure, and provides a signal to the economizer controller for modulating the position of the damper.

Minimum Position Potentiometer (W2 jumper):

The potentiometer controls the amount of outside air introduced in the building when the economizer damper closes or the air conditioner is Off or in Mechanical Cooling. The factory setting is for the damper to close completely when the unit is off or in Mechanical Cooling. (Pins 1 & 2 are jumpered)

If outside air is desired during mechanical cooling or whenever the indoor blower is running, jumper pins 2 & 3. Refer to item 8 in Figure 4 for the location of the jumper.

If the potentiometer is enabled, the next step is to select how much outside air should be brought into the building.

The potentiometer is adjustable from 0% to 100%. Setting the potentiometer to MIN means that the damper will close completely and NO outside air will be brought into the building. Setting the potentiometer to MAX means that the damper stays in the full OPEN position at all times. Factory setting is 50%.

Brand of Sensor Selection (W3 jumper)

Honeywell enthalpy and dry bulb sensors are currently the only brand of sensors used in the air conditioners. Jumper W3 allows us to use alternative brands at a future date. On all current air conditioners, pins 1 & 2 are jumpered on W3. See item 4 in Figure 4.

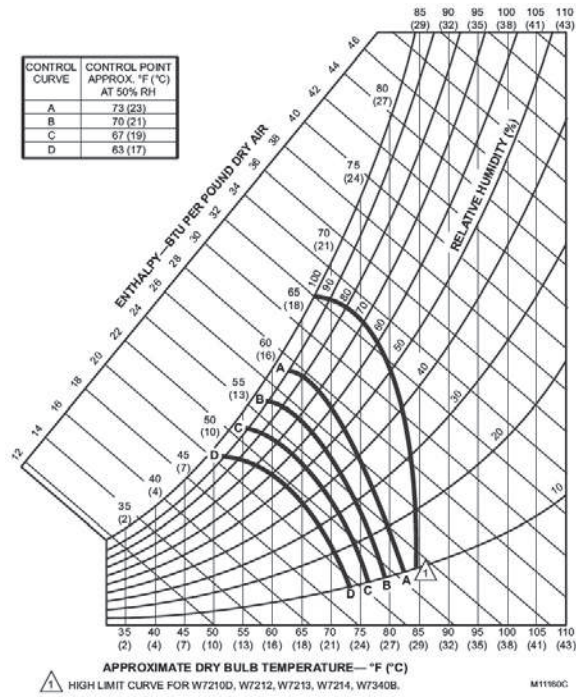

Figure 3. Enthalpy Sensor Temperature Control Points

Marvair Economizer Controller

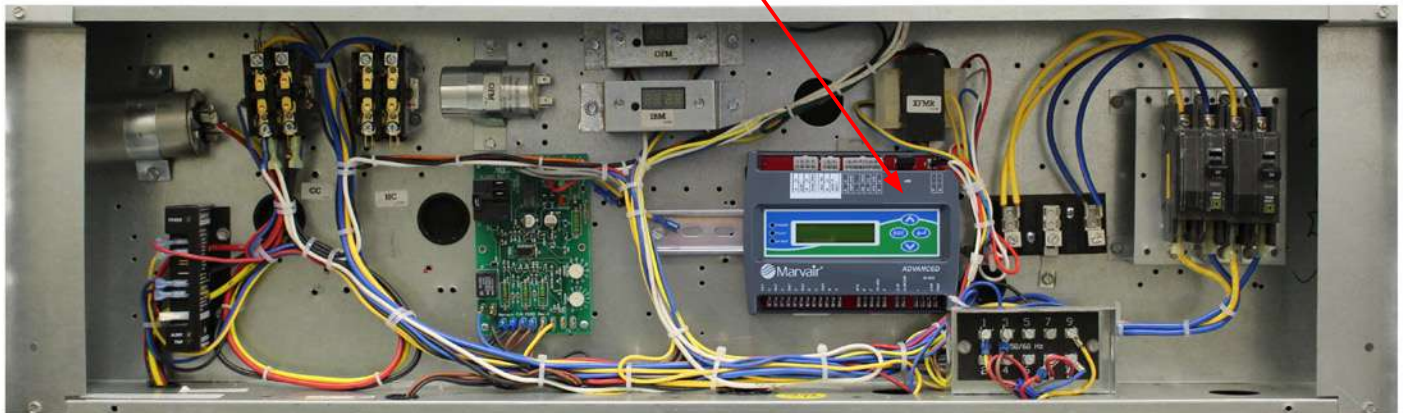
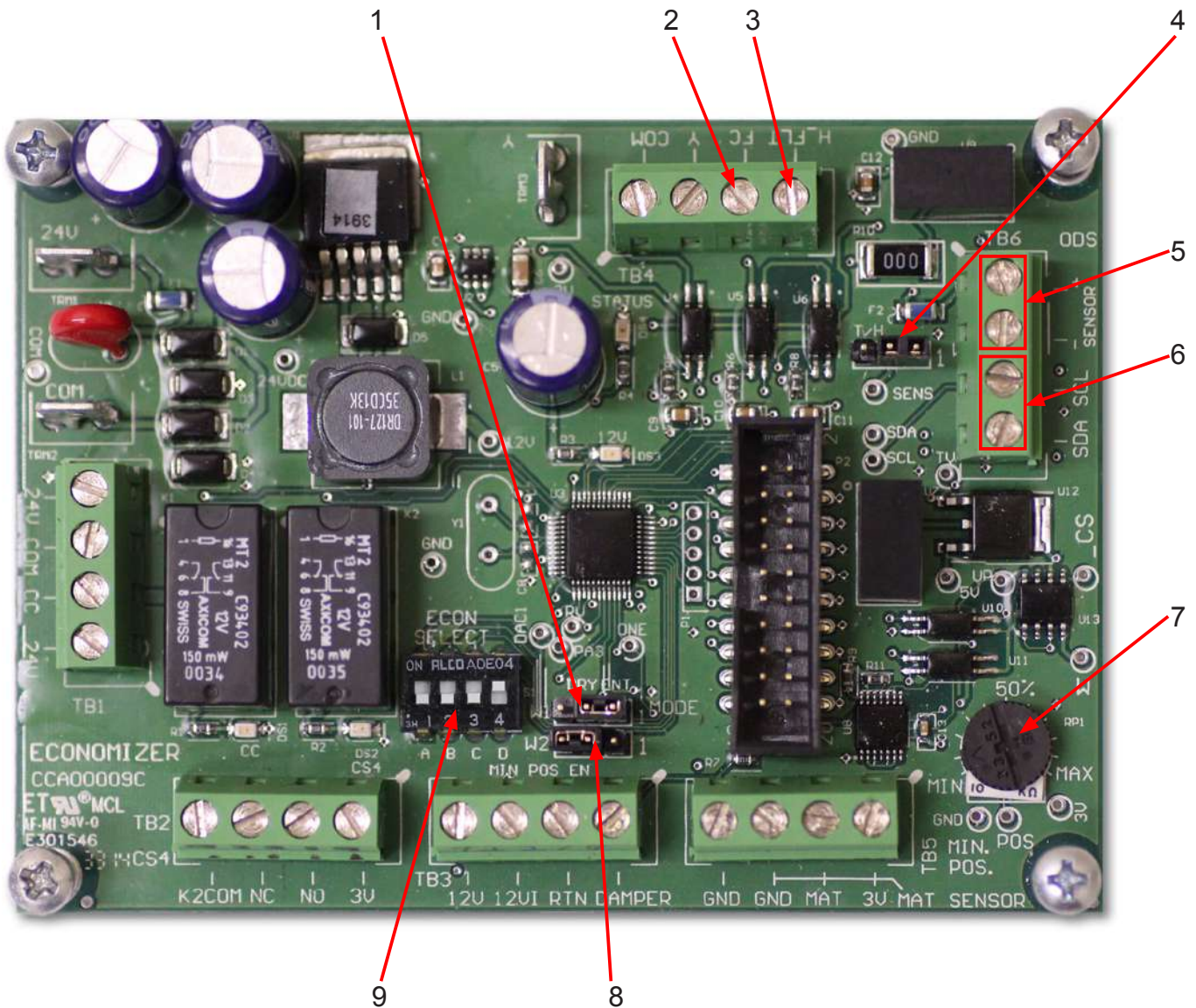

Figure 4. Electrical Controls, MAA Alternate Construction



- | | | |
|--|---|--|
| <p>1. W1 Economizer Sensor Selector
Jumper Pins 1 & 2 for enthalpy sensor
Jumper Pins 2 & 3 for dry bulb sensor</p> <p>2. Field connection from
CommStat 4 (2) terminal</p> <p>3. Field connection from CommStat 4
(MAR) terminal</p> | <p>4. W3 Sensor Brand Selector
Jumper Pins 1 & 2 for Honeywell sensor
Jumper Pins 2 & 3 for Prism sensor</p> <p>5. For Honeywell sensors</p> <p>6. For Prism sensors</p> | <p>7. Minimum Position Potentiometer
0% to 100%. Factory setting is 50%.</p> <p>8. W2 Minimum Position Potentiometer Jumper
Jumper Pins 1 & 2 to Disable (Factory setting)
Jumper pins 2 & 3 to Enable</p> <p>9. Enthalpy Dip Switches
Set points are same as previous
Honeywell controller.
Factory setting is 4 (63°F/17.2°)
1=A (73°F/23.8°C) 2=B (70°F/21.1°C)
3=C (67°F/19.4°C) 4=D (63°F/17.2°)</p> |
|--|---|--|

Figure 5. Economizer Control Board

Chapter 2 Electronic Control Board

2.1 Introduction



WARNING

Failure to observe the instructions contained in this document may result in personal injury and/or property damage and may void the warranty. Read this manual before installing, replacing or using this product.

Marvaair's proprietary Printed Circuit Board (PCB) sets the standard for the industry in flexibility, reliability and performance. This UL certified component is engineered to optimize Heating, Cooling and Dehumidification operation while communicating valuable information to the end user. Special features include 2-Stage operation with varying speed control to optimize latent and sensible capacity, built in remote communication (MODBUS) for monitoring and/or control, optimized head pressure control and the ability to function autonomously without the need for an off the shelf thermostat. The Marvaair PCB comes equipped with LEDs to monitor lockouts for independent circuits, which drastically reduces troubleshooting time and system downtime. Lockout contacts are also provided along with the alarms being transferred via MODBUS.

This chapter provides the necessary information for installing and operating the Marvaair PCB.

The diagram below identifies the inputs, outputs and connections for the Marvaair PCB.

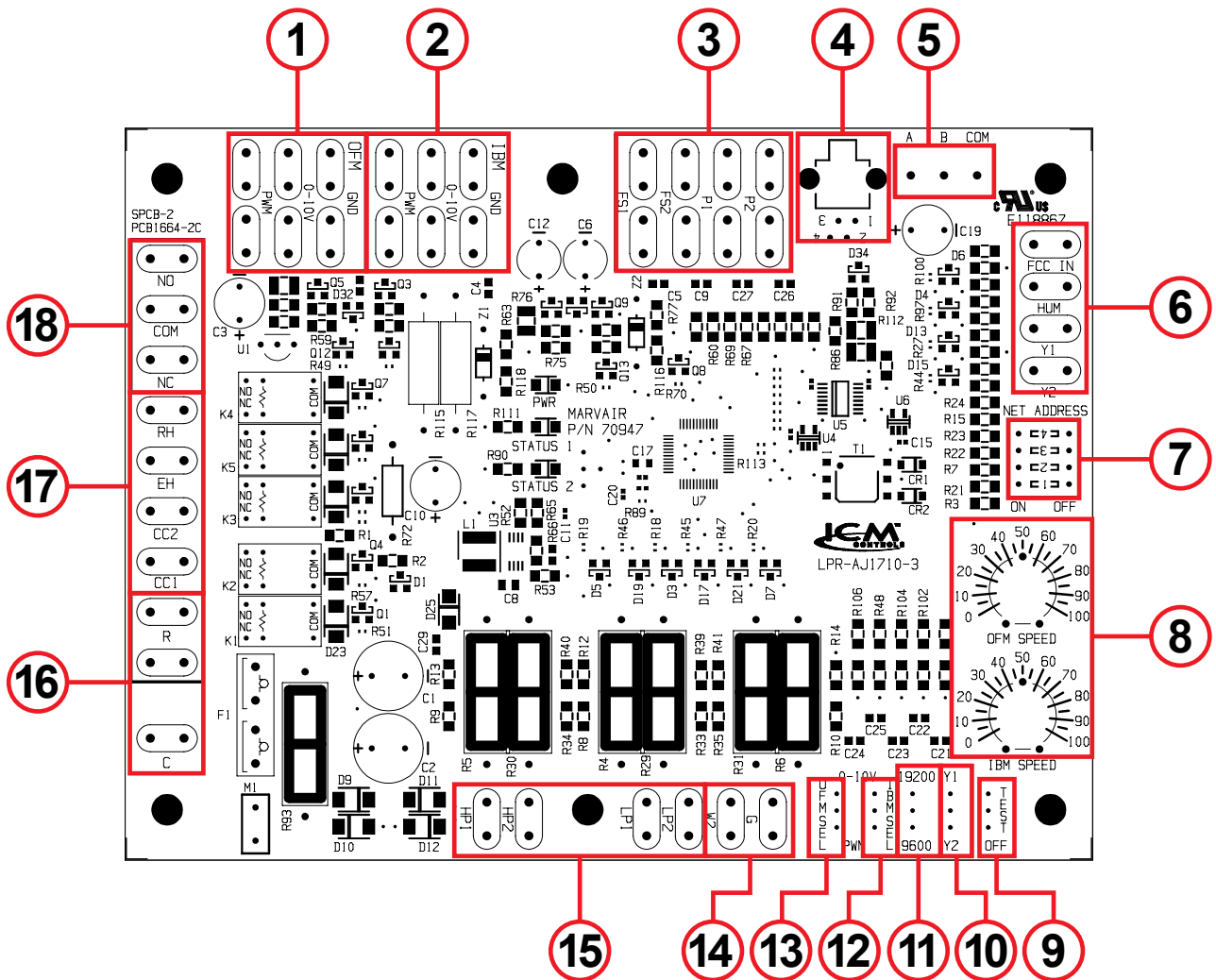

Item	Description
1	Outdoor Motor Control Signal Output
2	Indoor Motor Control Signal Output
3	P 1/2- Pressure for Circuit 1 and Circuit 2 (Respectively) FS1 – Freeze Stat for Circuit 1 FS2 – Indoor Temperature Input
4	Modbus Communication
5	3 Wire [A, B, COM] and Parallel RJ-11 Port
6	Fan Cycle Control Input (only Applicable for EC Outdoor Motors) Hum – Humidity Control Input (Connect to R Node) Y 1/2 - Cooling Request for Stage 1 and Stage 2 Cooling Operation
7	Modbus Network Address. Set All 4 to OFF for Local Control
8	Potentiometers for Indoor and Outdoor Speed
9	Energize or De-Energize Test Mode
10	Set Speed of Indoor Motor for Y1 and Y2 Operation
11	Set Baud Rate. 19.2k Between Top and Mid. 9.6k Between Mid and Bottom
12	Set Indoor Motor Control Signal Type
13	Set Outdoor Motor Control Signal Type
14	Thermostat Inputs: W2 – Heat Request G – Indoor Fan Request ON – Connect Respective Terminal to R Node. Off – Open Circuit
15	Pressure Switch Inputs for Respective Circuit HP – High Pressure Switch LP – Low Pressure Switch Switch to Be Closed for Cooling Operation. Switch to Be Connected to “R” Node
16	24 VAC Power Input to PCB.
17	Digital Outputs (24 VAC): The PCB Makes and Breaks R. RH – Reheat EH – Electric Heat CC 1/2– Compressor (Respectively)
18	Alarm Contacts

2.2 Installation and Replacement

The PCB is factory installed. To install a replacement PCB, use the six mounting holes along with the appropriate screw size to firmly secure the board to the control box. After this is achieved, follow the wiring diagram and pin configuration for the respective system for appropriate operation. Ensure that the terminals used do not make any unwanted electrical connection (via strands etc.) with any other terminals. Please allow a 1” creepage distance between the board and all other adjacent electrical components.

2.3 Operation

LED Status Indicators

Color	Type	Status	Description
Green	Power	Constant On	24 VAC power has been applied
Red	Status 1 and Status 2	Constant On	Normal Operation
		1 Blink	High pressure switch has opened twice
		2 Blinks	Low pressure switch has opened twice
		3 Blinks	Freeze stat (optional) - Indoor coil temperature is below 35°F (1°C)
		Continuous Flash of Both LEDs	Insufficient voltage to the board. Less than 20 Volts

Power

The Marvail PCB requires 24 VAC to operate. When the board is sufficiently powered, the “PWR” status light on the PCB illuminates “Green.” If there is insufficient power to the board, the “STATUS 1” and “STATUS 2” flashes continuously. Insufficient power to the board will result in no outputs being energized.

Setting the Speed for the Y1 and Y2 Operation for Indoor Motor

Put Bridge Jumper between the “Y1 pin and center pin” shown in the figure below. Use the potentiometer marked “IBM SPEED” to set the required speed for first stage cooling (Y1 request). Note that the type of control signal required by the motor must be set and the appropriate signal terminations must be used. This jumper will be factory installed. In replacing the PCB, verify the necessary signal and configure the board accordingly. Only 2 of the 3 pins should be used for the necessary configurations. **DO NOT CONNECT ALL 3 PINS.**

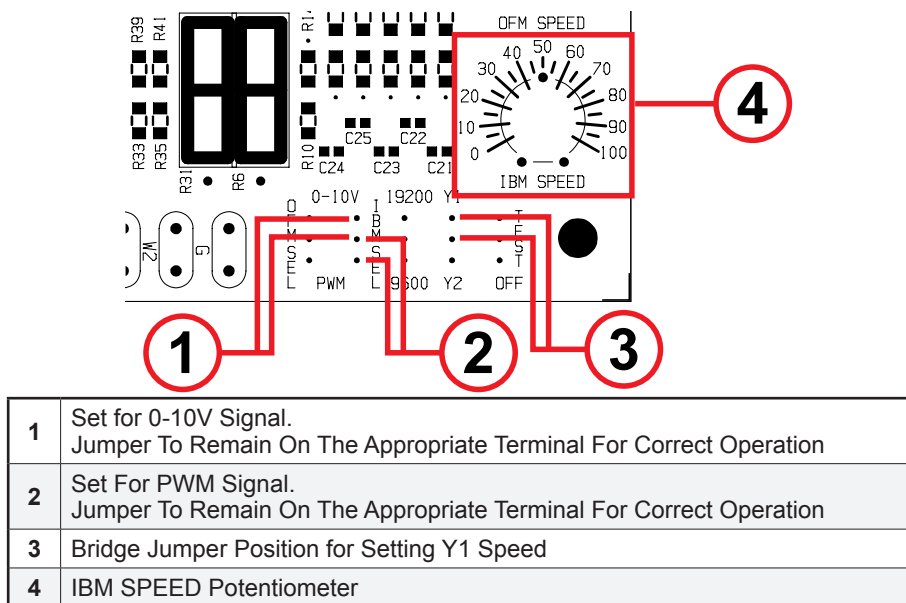

Figure 6a. Setting the Speed for the Y1 and Y2 Operation for Indoor Motor

To set second stage cooling (Y2 request) speed, put Bridge Jumper on the “Y2 pin and center pin” shown in the figure below. Use the potentiometer marked “IBM SPEED” to set the required speed.

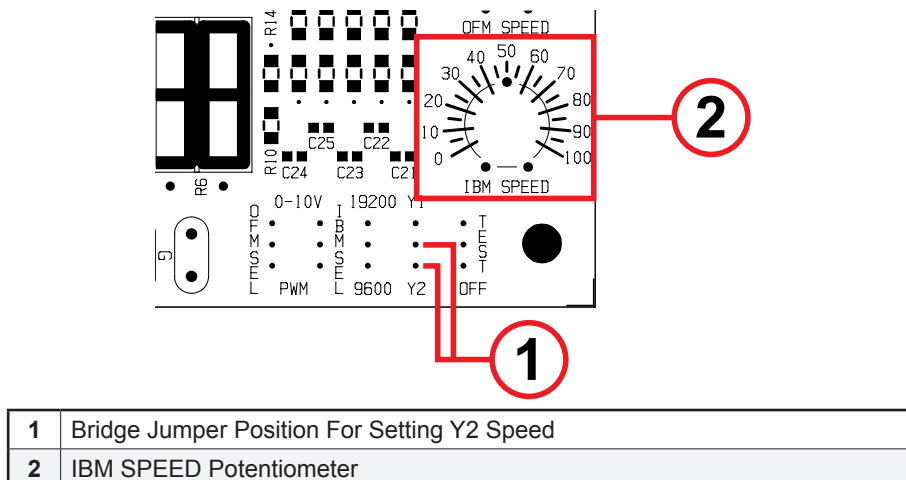

Figure 6b. Second Stage Cooling Speed

Output Termination for Indoor Motor Control Signal

Note: Follow data (wiring and signal control signal type) of the appropriate motor to setup the PCB

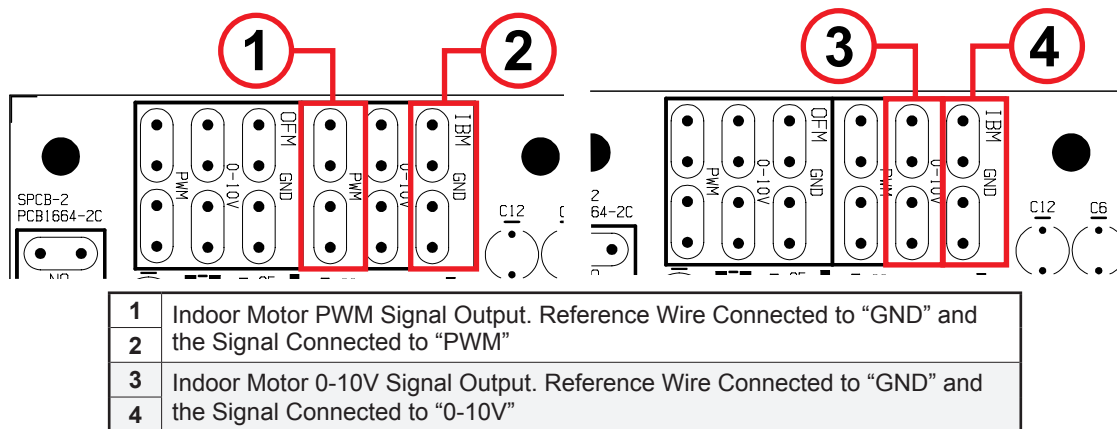

Figure 7. Output Termination for Indoor Motor Control Signal

Setting the Speed for Outdoor Motor

The Outdoor Motor runs at constant speed dictated by the potentiometer. See figure below.

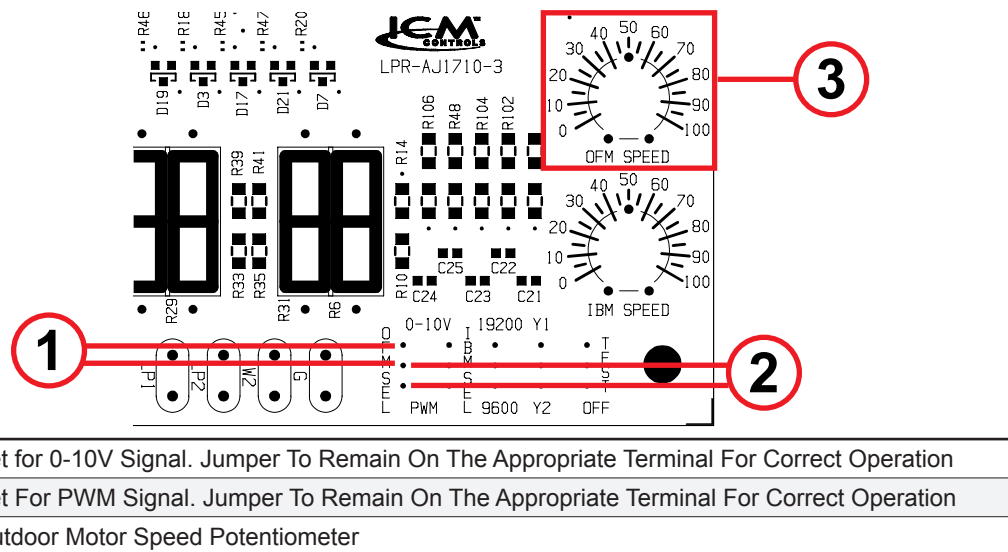

Figure 8. Outdoor Motor Speed Setting

Output Termination for Outdoor Motor Control Signal

Note: Follow data (wiring and signal control signal type) of the appropriate motor to setup the PCB.

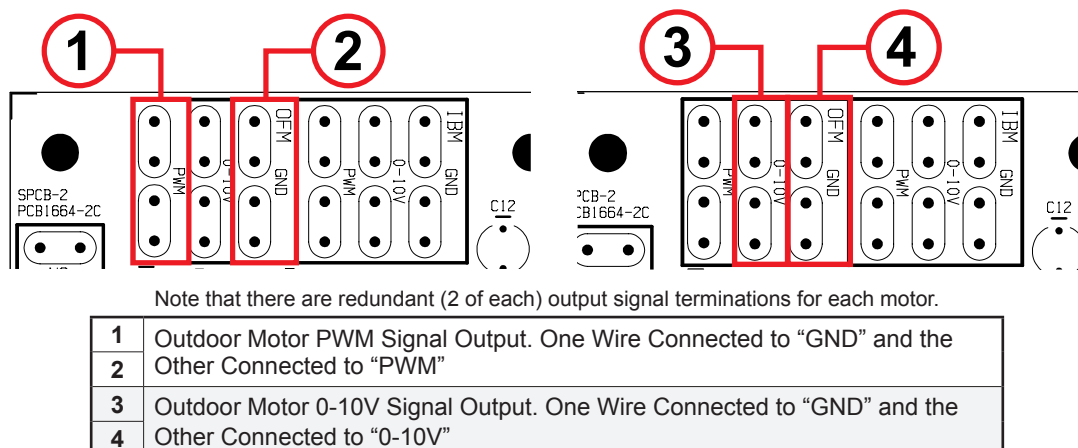
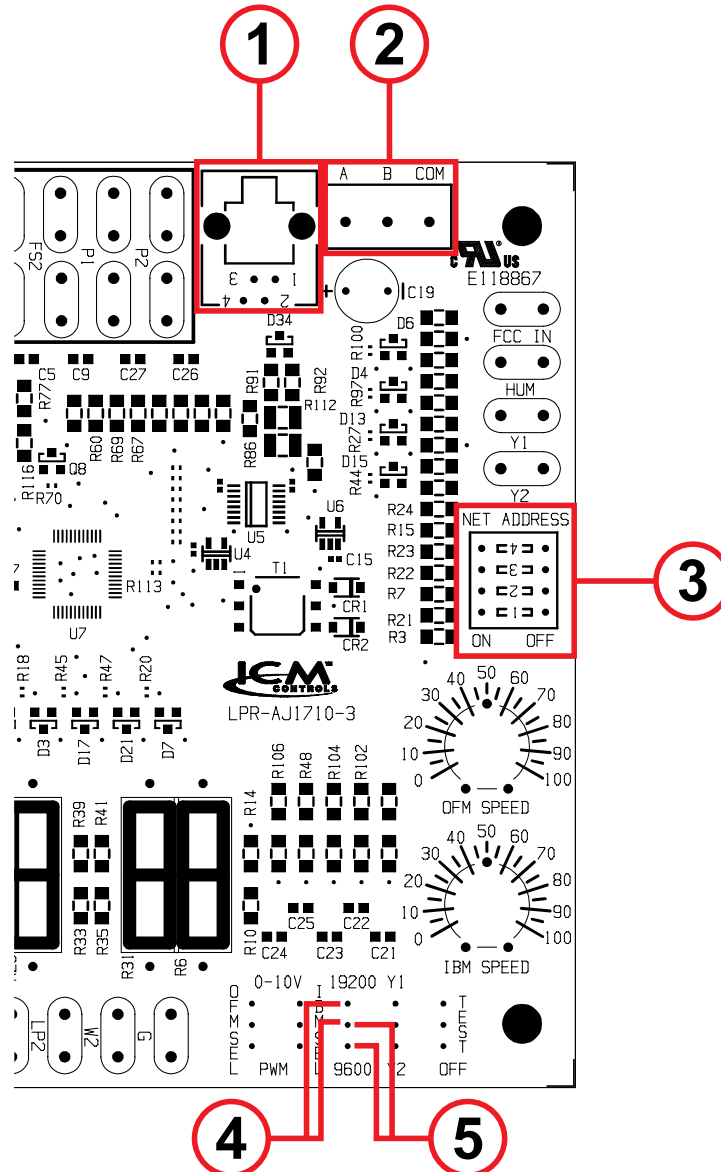

Figure 9. Output Termination for Outdoor Motor Control Signal

Communication

The Marvair PCB comes equipped with MODBUS communication standard. There are 2 adjacent MODBUS communication ports connected in parallel. That is, both ports transmit the same information. The difference between the ports is the physical connection. One port is for RS-485 (3 wire shielded cable is recommended) and the other port is RJ-11. The board allows you to set the Baud Rate at 9600 bits per second or 19200 bits per second. The board also allows 15 different MODBUS addresses based on the position of the “NET ADDRESS” DIP switches. The Net Addresses are written in Binary (see table below) with switch 4 being the least significant bit. **THE NUMBERS ON THE DIP SWITCHES DO NOT CORRELATE TO MODBUS ADDRESSES.** The figure below shows the positions of the various components necessary to set up communication on the PCB.



Note: No Parity; Serial Data Bit = 8; Stop Bit = 1

1	RJ-11 Termination
2	RS-485 Termination
3	MODBUS Network Address DIP switches. See Addressing Table
4	Baud Rate - 19200 BPS: Between Upper and Middle Pin
5	Baud Rate - 9600 BPS: Between Lower and Middle Pin

Figure 10. Communications SetUp

Address	DIP Switch 1	DIP Switch 2	DIP Switch 3	DIP Switch 4
0 [Local Control]	OFF	OFF	OFF	OFF
1	OFF	OFF	OFF	ON
2	OFF	OFF	ON	OFF
3	OFF	OFF	ON	ON
4	OFF	ON	OFF	OFF
5	OFF	ON	OFF	ON
6	OFF	ON	ON	OFF
7	OFF	ON	ON	ON
8	ON	OFF	OFF	OFF
9	ON	OFF	OFF	ON
10	ON	OFF	ON	OFF
11	ON	OFF	ON	ON
12	ON	ON	OFF	OFF
13	ON	ON	OFF	ON
14	ON	ON	ON	OFF
15	ON	ON	ON	ON

Table 6. MODBUS Network Address DIP Switch Positions

2.4 Sequence of Operation

IMPORTANT

All equipment should go through the recommended commissioning/start up sequence to ensure safety and system reliability. This document is only valid if the system is used as intended.

This section defines the manner and method of control of the HVAC system. It will cover the following operations and protections.

1.0 Blower Operation

2.0 Cooling Operation

2.1 Mechanical Cooling

2.1.1 Partial Capacity - 50-60%

2.1.2 Partial Capacity - 50%

2.1.3 Full Capacity

3.0 Heating

3.1 Electric Heat

4.0 Dehumidification

4.1 Independent Reheat Output

5.0 Refrigeration Protection

5.1 High Pressure Lockout

5.2 Low Pressure Lockout

5.3 Low Voltage

5.4 Anti-short Cycle

6.0 Additional Features

6.1 MODBUS communication

6.2 Modulating Head Pressure Control

6.3 Freeze Stat Operation

6.4 Onboard Thermostat

Equipment, devices and necessary system components are specified in the respective section.

Note:

1. All inputs on the Controller go through a 5 seconds Time-On Delay to prevent nuisance request. Compressor Outputs go through 5 seconds staggered Time On delay to prevent nuisance tripping of breaker due to the inrush associated with these large inductive loads.
2. Normal Operating Mode describes a mode in which there are no active faults which would interrupt the operation of the system.
3. A control voltage being “High” describes the event in which 24VAC is supplied to that input. Conversely, a “Low” control signal describes an event in which less than 5VAC is supplied to the

1.0 – Blower Operation

A request for Fan Only (independent G-signal via Digital input or MODBUS), results in the indoor motor turning “ON” and operating at the “Y2” motor speed (Only Applicable for EC motors). See Installation/ Operation manual to see how to set the speeds for the various operations. As long as there is a request for Fan (G-input High or a request for Indoor Fan Only via MODBUS), the indoor motor will continue to operate at the Y2 speed setpoint.

When there is a request for Indoor Fan (G-input High) along with a request for cooling, heating or dehumidification, the G-Input becomes lowest priority. This means that in any combination involving the G-input, the speed associated to Fan Only will never take precedence.

The priority list from Highest to Lowest goes as follows:

1. Stage 2 Cooling Request (Y2-Input)
2. Stage 1 Cooling Request (Y1-Input)
3. Electric Heat Request (W2-Input)
4. Dehumidification Request (Hum-Input)
5. Indoor Fan Request (G-Input)

Note – The priority list above also describes the operation that takes precedence in the event that there is a request for all operations or a combination of operations. The controller will NOT energize the compressor outputs and the heater output simultaneously.

The speed at which the Indoor Fan Operates during Stage 1 (Y1) and Stage 2 (Y2) Cooling Request can be set directly at the board using the jumper associated to the “Y1” and “Y2” pin. All other requests run at 80% of Y2 speed except for the lone G-input which runs at the Y2 speed settings. All requests are interlocked with the Indoor Fan and will run the Fan at the respective speed associated with the operation. This means that a lone call for Stage 1 (Y1) Cooling will automatically run the Indoor Fan at Stage 1 (Y1) Cooling Speed even without a request for Indoor Fan. This holds true for all request.

2.0 – Cooling Operation

2.1– Mechanical Cooling

This section will describe the sequence of operation which takes place during Direct Expansion (DX) cooling from a control standpoint.

2.1.1 Y1 Cooling (Partial Capacity 50-60%)

In normal operating mode, a request for “Stage 1 Cooling (Y-input)” via MODBUS, Digital Input or Onboard Thermostat, energizes Compressor 1 Relay Output (CC1) on the PCB. The controller provides a continuous control signal associated to the Indoor Fan Motor, that is proportional to the “Y1” speed setting on the board or via MODBUS. It also outputs a request dependent (based on FCC IN) control signal for the Outdoor Fan Motor. In Stage 1 Cooling operation, the compressor

and the indoor fan remains on continuously but the outdoor fan cycles based on head pressure. The Fan Cycle Control Switch (Low Ambient Control Switch) closes at 400 PSIG to set the “FCC IN” input High which in turn outputs a speed proportional to the “OFM Speed” setting on the board or by MODBUS. This brings on the outdoor fan which runs until the switch reopens (at 290 PSIG). These outputs function as described until the Cooling setpoint is satisfied.

2.1.2 Y2 Cooling (Partial Capacity 50%)

If the space temperature continues to increase pass the defined differential, Stage 2 Cooling (Y2-input) is energized. Under normal operation, this energizes the Compressor 2 Output (CC2). The Indoor Fan motor, will operate at “Y2” speed instead of “Y1” speed since Y2 has higher priority. These outputs remain energized until the cooling setpoint is satisfied. Once the setpoint is satisfied, the Compressor and the Outdoor fan outputs are de-energized. The Indoor motor continues to run for 90 seconds after the operation.

2.1.3 Y1 and Y2 Cooling (Full Capacity)

In the event that both Y1 and Y2 inputs are triggered, both CC1 and CC2 outputs are energized under normal conditions. The Indoor Fan motor, will operate at “Y2 speed” since Y2 has higher priority. Outputs described in the partial cooling operation above continue to function as described until the cooling setpoint is satisfied. Once the setpoint is satisfied, the Compressor and the Outdoor fan outputs are de-energized. The Indoor motor continues to run for 90 seconds after the operation.

Note: With staged compressors, a CC2 output without a CC1 output will neither result in partial capacity nor full capacity. Only CC1 output can achieve partial capacity. Both CC1 and CC2 outputs are required to achieve full capacity.

Request	Active Input	Active Output
Stage 1 Cooling (1 Fixed Compressor)	Y1	CC1 (Partial Capacity)
Stage 1 Cooling (2 Fixed Compressors)	Y1 or Y2	CC1 or CC2 Respectively (Partial Capacity)
Stage 1 Cooling (1 Staged Compressor)	Y1	CC1 (Partial Capacity)
Stage 2 Cooling (2 Fixed Compressors)	Y1 + Y2	CC1 + CC2 (Full Capacity)
Stage 2 Cooling (2 Staged Compressors)	Y1 + Y2	CC1 + CC2 (Full Capacity)
Stage 2 Cooling (2 Staged Compressors)	Y2	CC1 But the compressors will not run without CC1 being active. No Cooling.

3.0– Heating

3.1– Electric Heat

When there is a request for “Heating (W2-Input High)” via MODBUS, Digital Input or On-board Thermostat, the HVAC unit will run the Indoor Motor for 10 seconds prior to energizing the Heater Output. Once the Heater output is energized, the Heater comes on at full capacity (no staging). The Heater will remain on until the Heating setpoint is satisfied and the request is dropped. Once the heating setpoint is satisfied, the Indoor Fan will continue to run for 90 seconds while all other associated outputs are de-energized. Indoor Fan will default at 80% of Y2 speed.

4.0– Dehumidification

4.1– Independent Reheat Output

A request for “Dehumidification (Hum – Input High)” via MODBUS or Digital input will result in the control board energizing the Compressor 1 (CC1), Compressor 2 (CC2) and the Reheat (RH) relay outputs on the board. It also produces a continuous control signal for the Indoor Fan Motor that is proportional to the 80% (default) of the Y2 speed. The Outdoor Fan Motor is request dependent (based on “FCC IN” Input) and outputs a signal proportional to board or MODBUS setting when the “FCC IN” input is High. The board continues to produce these outputs until the Dehumidification request is dropped. Once this request is dropped, the Indoor Fan Motor continues to run for 90 seconds.

5.0 – Refrigeration Protection

5.1– High Pressure Lockout

This condition describes the abnormal rise in Head Pressure pass the system acceptable limit of 660 PSI (+/-20PSI). The fault will only be active when the High-Pressure Switch (Normally Closed) opens during a request for Cooling. The first time this fault condition occurs, the system cuts the compressor off WITHOUT locking out. Once the pressure normalizes (drops below 450 PSI), the system will resume operation if the cooling call still exist. If this fault occurs a second time on the same Cooling request, the system locks out. Lockouts can be monitored using the Status 1 and Status 2 LEDs. These LEDs correspond to a particular circuit and has a flash sequence associated to the various faults. The faults can also be monitored via MODBUS by reading the respective value based on the MODBUS map that is provided. After this lockout condition is reached, the cooling call must be cycled (on/off of respective cooling request) or the system must be power cycled to clear the fault. For a 2-compressor system, each lockout is isolated to the respective circuit and will not interfere with the operation of the other circuit providing that the circuits operate independently. The system will continue to lockout until the problem is rectified.

5.2– Low Pressure Lockout

This condition describes the abnormal fall in Suction Pressure below 40PSIG (+/- 5PSIG). This fault will only be active when the Low-Pressure Switch (Normally Closed) opens up during a request for Cooling. The Low-Pressure Switch is bypassed on the initial call for cooling for 3 minutes to allow low ambient start-up of the system. Once these 3 minutes have elapsed, if the switch is still open, the system cuts the compressor off. Once the pressure normalizes, the system will restart the cooling operation. In the event that the fault occurs a second time on the same call for cooling, the system locks out. To clear the fault, the Cooling request must be cycled or the system must be power cycled. Status LEDs with associated flash codes or designated MODBUS values can be monitored to verify this fault. The system will continue to lockout unit the problem is rectified.

5.3– Low Voltage

In the event that the board is experiencing low voltage (less than 20 Volts), both Status 1 and Status 2 LEDs flashes continuously (see LED Status Indicators). The board will not energize any outputs until this problem is rectified. This fault can be monitored at the board level via LEDs or via MODBUS.

5.4– Anti-Short Cycle

This is a built-in protection mechanism that increases the reliability of the compressor by protecting it from excessive short cycling. When the compressor goes off, due to any fault, emergency or if the cooling setpoint is satisfied, a built-in 3-minute timer locks the compressor for that respective circuit out. This can be monitored via MODBUS by referencing the appropriate register. However, it can only be monitored at the board level by waiting for the 3 minutes to elapse.

6.0 – Additional Features

5.1 – MODBUS Communication

To control the board via MODBUS, the board ID must be non-zero. “Zero” a MODBUS ID represents local control which allows the board to be controlled at the board level by Digital thermostatic inputs. If the MODBUS ID is non-zero, the board ignores all inputs from the board and inputs used are based on the MODBUS registers associated to the various Digital Inputs and Registers. Read Only registers and Coils can still be monitored but all read/write values MUST be configured at the MODBUS register/coil level and NOT at the board level.

The sequence of operation is the same as described above for the various operation, but Indoor Motor speeds for various operation, Outdoor Motor Speed, Heating Setpoint and Cooling Setpoint (if applicable) has to be configured via MODBUS. See MODBUS register tables at the end of this section.

5.2 – Modulating Head Pressure Control

A 10K Nominal NTC Thermistor is connected to the “P1” and “P2” inputs for circuit 1 and circuit 2 respectively. When this sensor is connected, the “FCC IN” is ignored and the thermistor value is used as the process variable when controlling the head pressure. The controller modulates the Outdoor Fan Motor to maintain a 90°F temperature setpoint. The controller will always use the greater value of P1 and P2 input as the reference point. In the event that the Thermistor is disconnected, the controller reverts to the “FCC IN” input to control the Head Pressure of the system.

5.3– Freeze Stat

A 10K Nominal NTC Thermistor is connected to the “FS1” input on the PCB. If the Thermistor is not connected, freeze protection will not be provided. If the Thermistor is connected, the control will provide the freeze protection by turning the compressor Off at a temperature of 35°F (+/- 2°F) on the Indoor Coil. The compressor will remain Off until the temperature measured is greater than 45°F and the anti-short cycle time has elapsed.

5.4– Onboard Thermostat

The Onboard Thermostat requires a 10K NTC thermistor to be connected to the “FS2” input. It also requires that the MODBUS functionality is enabled via MODBUS. The Heating Setpoint, Cooling Setpoint and Calibration of the sensor has to be configured via MODBUS. Once configuration is complete, the unit has the capability to function autonomously to maintain the space temperature.

**Discrete Registers:
Read with Function Code 02, Write to RW or WO registers with Function Code 05**

ID	Description	Size	Data Format	R/W
1	Current Status of the Y1 Compressor Call	1 Bit	0 = no call, 1 = call	RW
2	Current Status of the Y2 Compressor Call	1 Bit	0 = no call, 1 = call	RW
3	Current Status of the Humidity Call	1 Bit	0 = no call, 1 = call	RW
4	Current Status of the G Fan Call	1 Bit	0 = no call, 1 = call	RW
5	Current Status of the W2 Electric Heating Call	1 Bit	0 = no call, 1 = call	RW
6	Current Status of the FCC Call	1 Bit	0 = no call, 1 = call	RO
7	High Pressure Switch 1 Status	1 Bit	0 = Open, 1 = Closed	RO
8	High Pressure Switch 2 Status	1 Bit	0 = Open, 1 = Closed	RO
9	Low Pressure Switch 1 Status	1 Bit	0 = Open, 1 = Closed	RO
10	Low Pressure Switch 2 Status	1 Bit	0 = Open, 1 = Closed	RO
11	OFM Mode Selection	1 Bit	0 = PWM, 1 = 0-10V	RO
12	IFM Mode Selection	1 Bit	0 = PWM, 1 = 0-10V	RO
13	Test Mode Status	1 Bit	0 = Normal Mode 1 = Test Mode	RO
14	Status of Compressor 1 Relay Output	1 Bit	0 = Off, 1 = Energized	RO
15	Status of Compressor 2 Relay Output	1 Bit	0 = Off, 1 = Energized	RO
16	Status of RH RelayOutput	1 Bit	0 = Off, 1 = Energized	RO
17	Status of W2 RelayOutput	1 Bit	0 = Off, 1 = Energized	RO
18	Enables or Disables the internal Thermostat Functionality	1 Bit	0 = Off, 1 = Energized	RW
19	Enables or disables reading the thermostat inputs in Modbus mode	1 Bit	0 = Modbus only 1 = Read thermostat Inputs Default is 0	RW

Table 7a. MODBUS Discrete Registers

**Registers:
Read with Function Code 04, Write to RW or WO registers with Function Code 06**

ID	Description	Size	Data Format	R/W
1	Heat Setpoint	16 Bit	45°-100° F	RW
2	Cool Setpoint	16 Bit	45°-100° F	RW
3	Temperature Calibration	16 Bit	0-20, 10 is default. Less than 10 is a negative offset, 11-20 is a positive offset	RW
4	W2 Speed Multiplier	16 Bit	0-100, 80 is default. Represents a percentage of the Y2 fan speed	RW
5	Dehumidification Speed Multiplier	16 Bit	0-100, 80 is default. Represents a percentage of the Y2 fan speed	RW
6	OFM Set Speed	16 Bit	0 - 1023	RW
7	IFM Y1 Set Speed	16 Bit	0 - 1023	RW
8	IFM Y2 Set Speed	16 Bit	0 - 1023	RW
9	Modbus Timeout Setting	16 Bit	1 - 60, default 25; represents minutes of allowed MODBUS inactivity before switching to onboard T-Stat mode	RW
10	Current OFM Speed	16 Bit	0 - 1023	RO
11	Current IFM Speed	16 Bit	0 - 1023	RO
12	Anti Short Cycle Compressor 1	16 Bit	0 - 360, 0.5 sec. per step	RO
13	Anti Short Cycle Compressor 2	16 Bit	0 - 360, 0.5 sec. per step	RO
14	Voltage Reading	16 Bit	0 - 1023 1023 = Greater than 20V 965 = 18V cutoff	RO
15	P1 Temperature Reading	16 Bit	0°-160° F	RO
16	P2 Temperature Reading	16 Bit	0°-160° F	RO
17	Freeze Sensor 1 Temperature Reading	16 Bit	0°-160° F	RO
18	Freeze Sensor 2 Temperature Reading	16 Bit	0°-160° F	RO
19	Alarm Status	16 Bit	0 = No Fault 1 = Future Use 2 = HPS1 Fault 3 = Future Use 4 = HPS2 Fault 5 = Future Use 6 = Future Use 7 = LPS1 Fault 8 = LPS2 Fault 9 = Future Use 10 = Future Use 11 = Future Use 12 = Future Use 13 = Freeze Fault 1 14 = Freeze Fault 2 15 = Y1 Locked Out 16 = Y2 Locked Out 17 = Low Voltage	RO

Table 7b. MODBUS Registers

Chapter 3 Installation



WARNING

Failure to observe and follow Warnings and Cautions and these Instructions could result in death, bodily injury or property damage. Read this manual and follow its instructions and adhere to all Cautions and Warnings in the manual and on the A/C unit.

3.1 Equipment Inspection

Concealed Damage

Inspect all cartons and packages upon receipt for damage in transit. Remove cartons and check for concealed damage. **Important: keep the unit upright at all times.** Remove access panels and examine component parts. (Note: the "L"-shaped bottom bracket is screwed to the shipping pallet, against the air conditioner. Remove it before replacing the side screen). Inspect refrigerant circuit for fractures or breaks. The presence of refrigerant oil usually indicates a rupture. If damage is apparent, immediately file a claim with the freight carrier.

Units that have been turned on their sides or tops may have concealed damage to compressor motor mounts or to the oil system. If the unit is not upright, immediately file a claim for concealed damages and follow these steps:

1. Set unit upright and allow to stand for 24 hours with primary power turned on.
2. Attempt to start the compressor after 24 hours.
3. If the compressor will not start, makes excessive noise, or will not pump, return the unit to the freight carrier.

3.2 Installation Requirements

General

1. Inspect unit for completeness. Check for missing parts (e.g. hardware). Refer to the installation kit information in section 2.3.
2. Remove access panels and check for loose wires. Tighten screw connections.
3. Complete and mail the warranty registration card.

You must consider all of the following when choosing the installation site:

1. **Noise.** Install the unit so that the least amount of noise will be transmitted to inhabited spaces.
2. **Condensate Drainage.** Condensate produced during operation must be discharged to a suitable drain.
3. **Placement.**
 - A) Place the unit in a shaded area, if possible.
 - B) Install it above ground for protection against flooding.
 - C) The unit exhausts air. Be sure that the airflow is not impeded by shrubbery or other obstructions.
 - D) When installing multiple units, please note the recommended clearances noted in Table 4.
4. **Airflow Requirements:**

Note the maximum static pressure (Table 6). Keep duct lengths as short as possible. Do not obstruct airflow through the unit.

Duct work should be designed and installed in accordance with *all* applicable safety codes and standards. Marvair® strongly recommends referring to the current edition of the National Fire Protection Association Standards 90A and 90B *before* designing and installing duct work. The duct system must be engineered to insure sufficient air flow through the unit to prevent over-heating of

the heater element. This includes proper supply duct sizing, sufficient quantity of supply registers, and adequate return and filter areas. Duct work must be of correct material and must be properly insulated. Duct work must be constructed of galvanized steel with a minimum thickness of .019 inches. Duct work must be firmly attached, secured, and sealed to prevent air leakage. See section 2.4 for additional duct work requirements.

5. **Clearances:**

Note the minimum clearances required for proper operation and service.

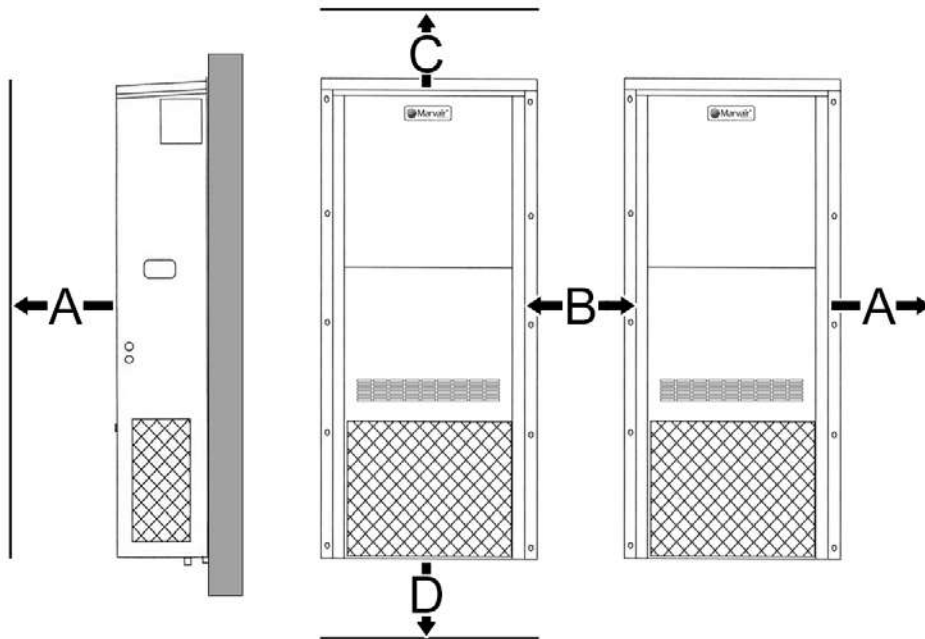

MODEL	MIN. CLEARANCE AROUND SIDES (SINGLE UNIT)	MIN. CLEARANCE BETWEEN UNITS (TWO UNITS)	MIN. SPACE ABOVE UNIT	MIN. SPACE BELOW UNIT
	A	B	C	D
1018/1020/1024	30 inches (76 cm)	18 inches (46 cm)	24 inches (61 cm)	6 inches (15 cm)
1030/1036	30 inches (76 cm)	18 inches (46 cm)	24 inches (61 cm)	6 inches (15 cm)
1042/1048/1060	30 inches (76 cm)	30 inches (76 cm)	24 inches (61 cm)	6 inches (15 cm)
1072	30 inches (76 cm)	30 inches (76 cm)	12 inches (31 cm)	6 inches (15 cm)

Table 8. Minimum Clearances

6. **Codes:**

Make sure your installation conforms to all applicable electrical, plumbing, building, and municipal codes. Some codes may limit installation to single story structures.

7. **Electrical Supply:**

The power supply must have the appropriate voltage, phase, and ampacity for the model selected. Voltage must be maintained above minimum specified values listed below. Refer to the data sticker on the unit for ampacity requirements.

Electrical Rating Designations*	A	C	D	Z
Nominal Voltage	208/230	208/230	460	575
Phase	1	3	3	3
Minimum Voltage	197	197	414	518
Maximum Voltage	253	253	506	632

* Letters refer to model number code designations. Refer to page 5.

Table 9. Voltage Limitations

3.3 Installation Materials

Installation Kits

Marvair air conditioners are shipped with one 12 Ga. "L" shaped bottom bracket. If you have not yet unpacked the unit, follow the instructions in section 2.1. All units have built-in full length mounting flanges. Therefore, use of mounting brackets is not required.

Kit Components:

1. One 12 Ga. "L"-shaped bottom bracket.

Accessories:

The package may include other factory-supplied items (optional) as follows on the next page:

Controllers/Thermostats

CommStat 6 2/4 Telecom HVAC Controller	P/N 70705
CommStat 6 4/8 Telecom HVAC Controller	P/N S/12087-04
CommStat 6 6/12 Telecom HVAC Controller	P/N S/12087-06
CommStat 4 HVAC Controller, Solid State Lead/Lag Controller	P/N S/07846
CommStat 3 HVAC Controller, Solid State Lead/Lag Controller	P/N S/04581

Digital thermostat. 1 stage heat, 1 stage cool. 7 day programmable. Fan switch:
Auto & On. Auto-change over. Keypad lockout. Non-volatile program memory. P/N 50123

Digital thermostat. 2 stage heat, 2 stage cool. 7 day programmable. Fan switch:
Auto & On. Auto-change over. Status LED's. Backlit display.
Programmable fan. Non-volatile program memory. P/N 50107

Grilles/Wall Sleeves

Supply Grilles

For MAA1018A - 17" x 5" (432 mm x 127 mm)	P/N 80682
For MAA1020A, MAA1024A, MAA1024A "B2" - 20" x 8" (508 mm x 203 mm)	P/N 80674
For MAA1030A, MAA1030A "B2", MAA1036A, MAA1036A "B2" - 28" x 8" (711 mm x 203 mm)	P/N 80675
For MAA1042A, MAA1048A MAA1060A - 30" x 10" (762 mm x 254 mm)	P/N 80676
For MAA1060A, MGA1702A Reverse Flow - 30" x 16" (762 mm x 406 mm)	P/N 93197
For MGA1072 - 30" x 10" (762 mm x 254 mm)	P/N 80676

Return Grilles

For MAA1018A - 17" x 10" (432 mm x 254 mm)	P/N 93252
For MAA1018, MAA1020A, MAA1024A - 20" x 12" (508 mm x 305 mm)	P/N 80677
For MAA1024A "B2" - 22 ¹ / ₈ " x 14 ¹ / ₈ " (562 mm x 359 mm)	P/N 80671
For MAA1030A, MAA1036A - 28" x 14" (711 mm x 356 mm)	P/N 80678
For MAA1030A "B2", MAA1036A "B2" - 30 ¹ / ₈ " x 16 ¹ / ₈ " (765 mm x 410 mm)	P/N 80672
For MAA1042A, MAA1048A MAA1060A - 30" x 16" (762 mm x 406 mm)	P/N 80679
For MAA1060A, MGA1072A Reverse Flow - 30" x 10" (762 mm x 254 mm)	P/N 93198
For MGA1072 - 30" x 16" (762 mm x 406 mm)	P/N 80679

Return Filter Grilles

Used when filter must be changed from the interior. Not recommended for economizer equipped air conditioners.

Note: Filter used in Return Filter Grille is 1" (25 mm) thick.

For MAA1020A, MAA1024A, MAA1024A "B2" - 20" x 12" (508 mm x 305 mm)	P/N 80671
For MAA1030A, MAA1030A "B2", MAA1036A, MAA1036A "B2" - 28" x 14" (711 mm x 356 mm)	P/N 80672
For MAA1042A, MAA1048A MAA1060A - 30" x 16" (762 mm x 406 mm)	P/N 80673

Additional Items Needed:

Additional hardware and miscellaneous supplies (not furnished by Marvair®) are needed for installation. For example, the list below contains approximate quantities of items typically needed for mounting a unit on a wood frame wall structure. Concrete or fiberglass structures have different requirements.

- (10) **3/8" carriage head mounting bolts** for unit mounting flanges. The length needed is typically the wall thickness plus one inch.
- (20) **3/8" washers**
- (10) **3/8" hex nuts**
- (6) **3/8" x 2-1/2" lag screws** for bottom bracket
 - **Silicone Sealer** to seal around cracks and openings
 - **Minimum 5 conductor low voltage multicolored wire cable** (i.e. thermostat wire)
 - **Appropriate electrical supplies** such as **conduit, electrical boxes, fittings, wire connectors,** etc.
 - **High voltage wire**, sized to handle the MCA (minimum circuit ampacity) listed on the data plate.
 - **Over-Current Protection Device** sized in accordance with the MFS (maximum fuse size) listed on the unit data plate.

WARNING - FIRE HAZARD

Improper adjustment, alteration, service, maintenance or installation could cause serious injury, death and/or property damage.

Installation or repairs made by unqualified persons could result in hazards to you and others. Installation MUST conform with local codes or, in the absence of local codes, with codes of all governmental authorities have jurisdiction.

The information contained in this manual is intended for use by a qualified service agency that is experienced in such work, is familiar with all precautions and safety procedures required in such work, and is equipped with the proper tools and test instruments.

3.4 Porting and Duct Work

General Information

Note: The following instructions are for general guidance only. Due to the wide variety of installation possibilities, specific instructions will not be given. When in doubt, follow standard and accepted installation practices, or contact Technical Support for additional assistance.

Wall Openings (All MAA/MGA air conditioners)

Measure the dimensions of the supply and return ports on the unit.

Cut the openings in the exterior wall for the supply and return. **IMPORTANT: All units with electric heat must have 1" (25.4mm) clearance on all four sides of the supply outlet duct flange on the unit. The 1" (25.4mm) clearance must extend on all sides of the supply duct for the first 3 feet (1 meter) from the unit.**

IMPORTANT: Marvair® requires a minimum of 1" (25.4mm) from the surface of any supply ducts to combustible material for the first 3 feet (1 meter) of the duct.

For all air conditioners with electric heat, the wall sleeve **MUST** have 1" (25.4 mm) clearance around all four sides of the opening. Attach the perimeter flange of the wall sleeve to the framed opening with appropriately sized screws. Since electric heat can be added after the unit has been installed, Marvair recommends that all installations have the 1" (25.4 mm) clearance around the wall sleeve.

When installing the wall sleeve, the supply opening must be on top. The supply opening is smaller than the return air opening.

Ducting

Extensions should be cut flush with the inside wall for applications without duct work.

Applications using duct work should be designed and installed in accordance with *all* applicable safety codes and standards. Marvair® strongly recommends referring to the current edition of the National Fire Protection Association Standards 90A and 90B *before* designing and installing duct work. The duct system must be engineered to insure sufficient air flow through the unit to prevent over-heating of the heater element. This includes proper supply duct sizing, sufficient quantity of supply registers, adequate return and filter area. Ductwork must be of correct material and must be properly insulated. Duct work must be constructed of galvanized steel with a minimum thickness of .019 inches for the first 3 feet (1 meter). Ductwork must be firmly attached, secured and sealed to prevent air leakage. Do not use duct liner on inside of supply duct within 4 feet (122cm) of the unit.

Galvanized metal duct extensions should be used to simplify connections to duct work and grilles. Use fabric boots to prevent the transmission of vibration through the duct system. The fabric must be U.L. rated to a minimum of 197°F (92°C).

Minimum Airflow Requirements

The duct system must be engineered to assure sufficient air flow through the unit even under adverse conditions such as dirty filters, etc. Use **Table 6** below and **Table 1, CFM at External Static Pressure (Wet Coil)** in section 1.4.

BASIC MODEL	MAXIMUM STATIC
MAA1018/1020/1024	.50
MAA1030/1036	.50
MAA1042/1048/1060	.50
MGA1072	.50

Table 10. Maximum Static Pressure (For units with 2" Pleated Filters)

3.5 Fresh Air Hood (non-economizer air conditioners only)

The fresh air hood is located on the inside, behind the slots on the bottom front panel. To access the hood, remove the screws that hold the front panel. The air flow can be adjusted from no (0%) fresh air to approximately 15% of rated air flow of fresh air, in 5% increments. The hood is shipped from the factory in the closed position (no fresh air). To provide fresh air, remove the two screws on either side of the hood and reposition as desired.

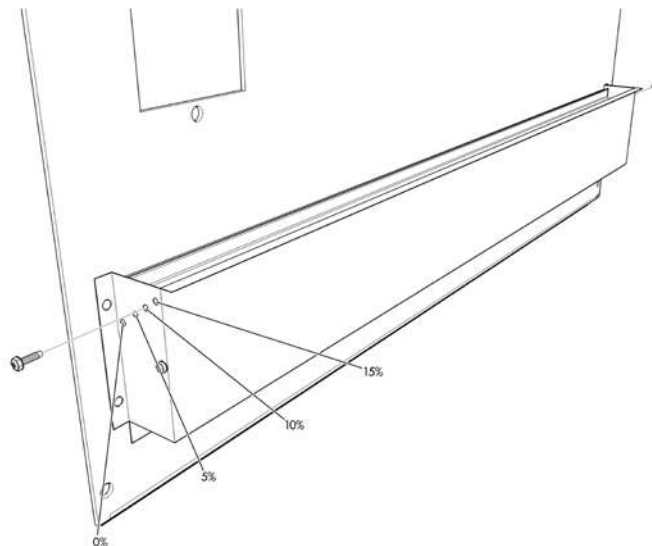

Figure 11. Fresh Air Hood Damper, Models 1024-1072

3.6 Bracket Installation

1. All models have built-in mounting flanges.
2. Apply a bead of silicone sealer on the wall side of the bottom support brackets on the unit. Circle the mounting holes with the silicone bead.
3. Refer to Figure 4. Attach the bottom support bracket to the wall using appropriate 3/8" diameter hardware.

For example, on wooden structures, use 3/8" x 2-1/2" all-thread lag screws. The screws must penetrate the center of the wall stud. Drill a pilot hole in the stud to prevent it from splitting.

3.7 Mounting The Unit

1. For wiring into the back of unit, locate the lower of the two knockouts on the wall side of the unit. Drill a one inch hole in the shelter wall to match this opening. Allow sufficient clearance to run 3/4" conduit through the hole and to the unit.
2. Using an appropriate and safe lifting device, set the unit on the bottom support bracket mounted on the wall. You must stabilize the unit on the bracket with the lifting device or by some other means - the bracket alone is not sufficient.
3. Make sure that the duct flanges are properly aligned with the wall opening. Adjust as necessary.
4. Note the holes in each side flange. Using the holes for guides, drill holes through the wall with a 3/8" drill bit. Insert the 3/8" x 5" bolts through the flanges. Install nuts and washers on the inside of the shelter. Tighten the bolts to secure the unit.
5. Apply a bead of silicone where the mounting flange contacts the unit and the shelter wall.
6. On the inside of the shelter, install the wall sleeves in the supply and return air openings. The sleeves may be trimmed to fit flush with the inside wall.
7. Check the fit of each sleeve to its mating flange for possible air leaks. Apply silicone sealer to close any gaps. Install the air return and supply grilles.

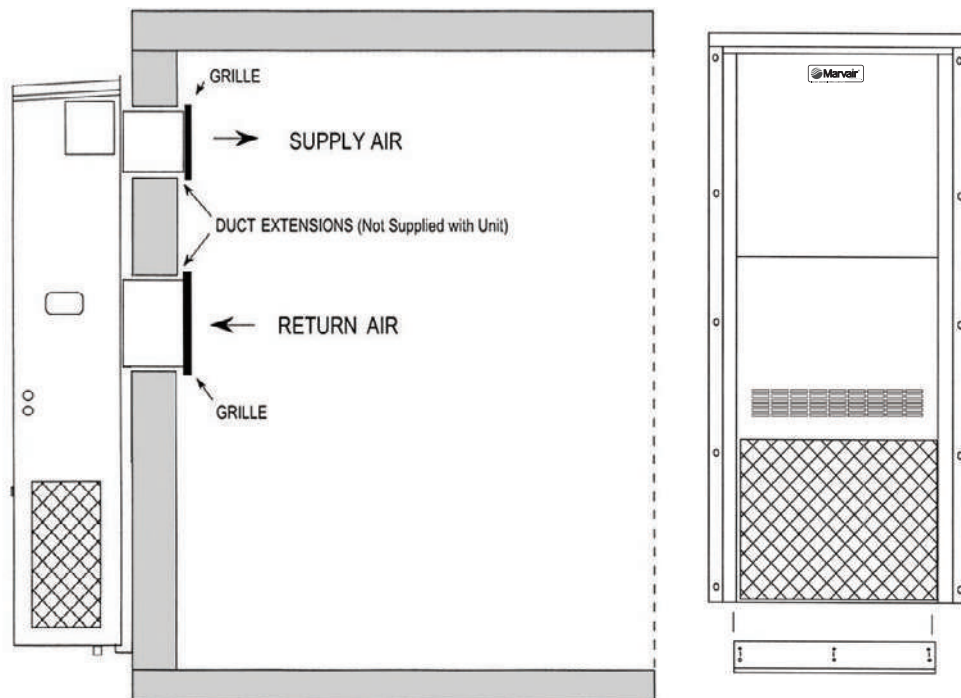

For units with electric heat, a one inch clearance is required around the duct extensions. The duct extensions must be constructed of galvanized steel with a minimum thickness of .019" as per the NFPA standards 90A & 90B.

Figure 12. Marvair A/C Wall Mount Detail

3.8 Electrical Connections



WARNING

ELECTRICAL SHOCK HAZARD

Failure to follow safety warnings exactly could result in serious injury, death, and/or property damage.

Turn off electrical power at fuse box or service panel BEFORE making any electrical connections and ensure a proper ground connection is made before connecting line voltage.

Important

All electrical work must meet the requirements of local codes and ordinances. Work should be done **only** by qualified persons.

Units may incorporate an internal crankcase heater for compressor protection. **The crankcase heater must be energized for at least 24 hours prior to starting the compressor.**

Scroll compressors, like several other types of compressors, will only compress in one rotational direction. The direction of rotation is not an issue with single-phase compressors since they will always start and run in the proper direction. However, three phase compressors will rotate in either direction depending upon phasing of power. Since there is a 50-50 chance of connecting power in such a way as to cause rotation in the reverse direction, it is imperative to confirm that the compressor is rotating in the proper direction at the initial field start-up of the system. Verification of proper rotation is made by observing that the suction pressure drops and the discharge pressure rises when the compressor is energized. An alternate method of verification for self contained system with small critical refrigerant charges, where the installation of gauges may be objectionable, can be made by monitoring the temperature of the refrigerant lines at the compressor. The temperature should rise on the discharge line while the suction line temperature decreases. Reverse rotation also results in a substantially reduced current draw when compared to tabulated values.

There is no negative impact on durability caused by operating three phase compressors in the reversed direction for a short duration of time, usually defined as less than one hour. However, after several minutes of operation the compressor's internal protector will trip. The compressor will then cycle on the protector until the phasing is corrected. Reverse operation for longer than one hour may have a negative impact on the bearings.

To change the rotation, turn off power to the unit and reverse L1 & L2 at the disconnect in the air conditioner.

High Voltage Wiring - (Single Units)

The power supply should have the proper voltage, phase, and ampacity for the selected model.

1. Refer to the electrical data on the data sticker on the unit for field wiring requirements of the unit. Size the incoming power supply lines and the fuse(s) or HACR breaker(s) according to requirements described in the National Electric Code. Run the power conductors through the knockouts on the side or back of the unit. Use appropriate conduit and strain reliefs.



CAUTION

Note: Power supply service must be within allowable range (+10% - 5%) of rated voltage stamped on the unit rating plate. To operate nominal 230/208V unit at 208V, change the transformer line tap from 240V to 208V following the instruction on wiring label in unit.

2. Connect the wires to the input side of the internal breaker or terminal block (L1 & L2 for single-phase units; L1, L2, & L3 for three-phase models).
3. Install the ground wire on the ground lug.
4. For units designed for operation on 208/230V, 60Hz power supply, the transformer is factory wired for a 230V power supply. For a 208V power supply, remove the orange lead from the transformer and connect the red lead. Insulate the orange lead.
5. 460V units have a step down transformer for 230V motors.

⚠ CAUTION

The external breaker(s) that provide power to the air conditioner must be sized per the maximum Fuse Size (MFS) shown on the Unit's data label.

Dual Unit Phasing

For applications where one controller operates two units, e.g., the CommStat 4 or CommStat Touch HVAC controller.

Newer HVAC controllers such as the CommStat do not require unit phasing. However, if other devices are connected to the control system, phasing of the air conditioner is required. Earlier models; i.e., LL357, LL357A, LL357D2 require the unit to be properly phased.

1. Wire each unit as described in steps 1 through 4 above.
2. Test for proper phasing as follows:
 - A. Power up the units.
 - B. Using an AC volt meter set to the 300 volt scale, measure voltage between terminal L1 on the compressor contactor of unit #1 and terminal L1 on the compressor contactor of unit #2. If voltage is present, units are wired out of phase and must be rewired.
 - C. If units are not in phase, turn off power and reverse the field power leads connected to the internal circuit breaker on one of the units only.
 - D. Restore power and retest the phase (step B). When the voltage reads "0", the units are in phase.
 - E. Turn off power and proceed.

Low Voltage Wiring

IMPORTANT. The following instructions are generic wiring instructions and may not be applicable for air conditioners with various options. Always refer to the wiring diagram in the air conditioner for the proper method to wire your unit.

1. On single units, pull the low voltage wiring (e.g., 18 gauge 4-conductor Class 2 thermostat wire) from the unit into the thermostat / subbase assembly. See Figure 9b for connections to various thermostats.
2. Mount the thermostat on the wall of the shelter. The thermostat should be located so that the supply air from the unit does NOT blow directly on to the thermostat. Connect the thermostat to the terminal block in the air conditioner as shown in Figures 9a and 9b.
3. On dual units, refer to the *CommStat Touch, CommStat 4 or CommStat 3 HVAC Controller Specification sheet*. Level and install the controller subbase. Wire the two A/C units to the Lead/Lag Controller, according to the wiring diagram on the specification sheet and as shown in Figure 9c or 9d (note: the diagram also appears on the back cover of the controller).

Remote Signalling: Terminals 5 & 7(N.O.) and 6 & 7 (N.C.) on the terminal board are dry contacts which can be used for remote signalling in the event of a/c cutoff on low or high pressure limit.

Continuous fan operation: For continuous indoor fan operation on single units, install a jumper between terminals 8 and 3. For continuous indoor fan operation on dual units using the older LL357D4, install jumper between 8 and 3 and remove jumper between 1 and 3.

CommStat Touch Lead /Lag Controller (See Figure 9c)

Please refer to the Product Data sheet for the Commstat Touch controller for complete instructions on installing and programming this controller.

CommStat 4 Lead /Lag Controller

Please refer to the Product Data sheet for the Commstat 4 controller for complete instructions on installing and programming this controller.

CommStat 3 Controller (See Figure 9d)

The CommStat 3 Controller is a solid state control package designed to operate a fully or partially redundant air conditioning system for a telecommunication cabinet or shelter. The CommStat 3 Controller is factory programmed with standard industry set points to facilitate installation. If desired, each of the set points can be quickly and easily changed in the field by the installer. It can be used with Marvair's unique vertical packaged wall mount air conditioners or other environmental control units. See CommStat 3 Product Data Sheet for installation and programming instructions.

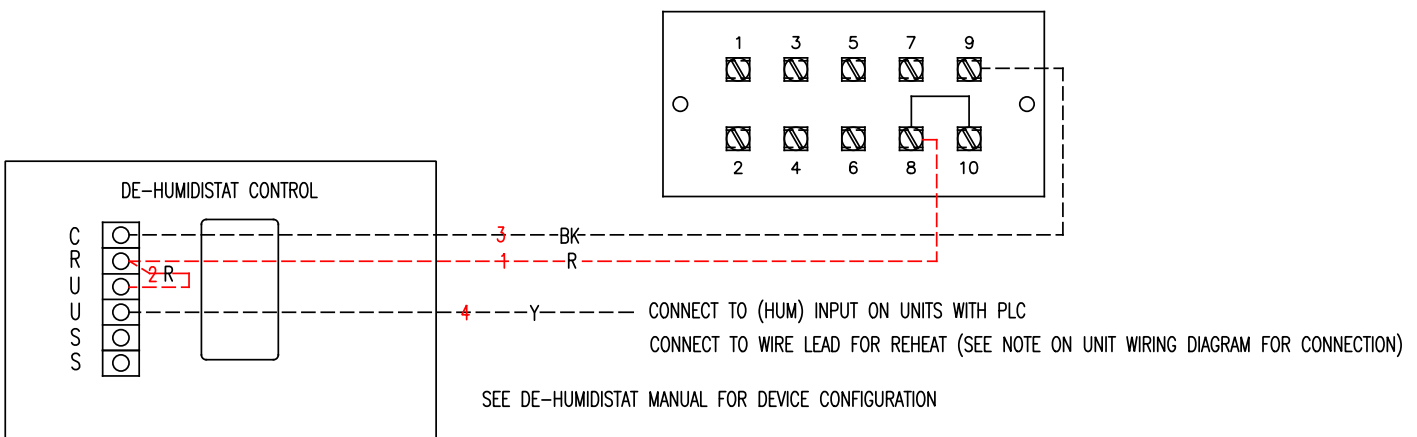

Figure 13a. Humidistat Wiring to a Marvair Air Conditioner with Reheat.

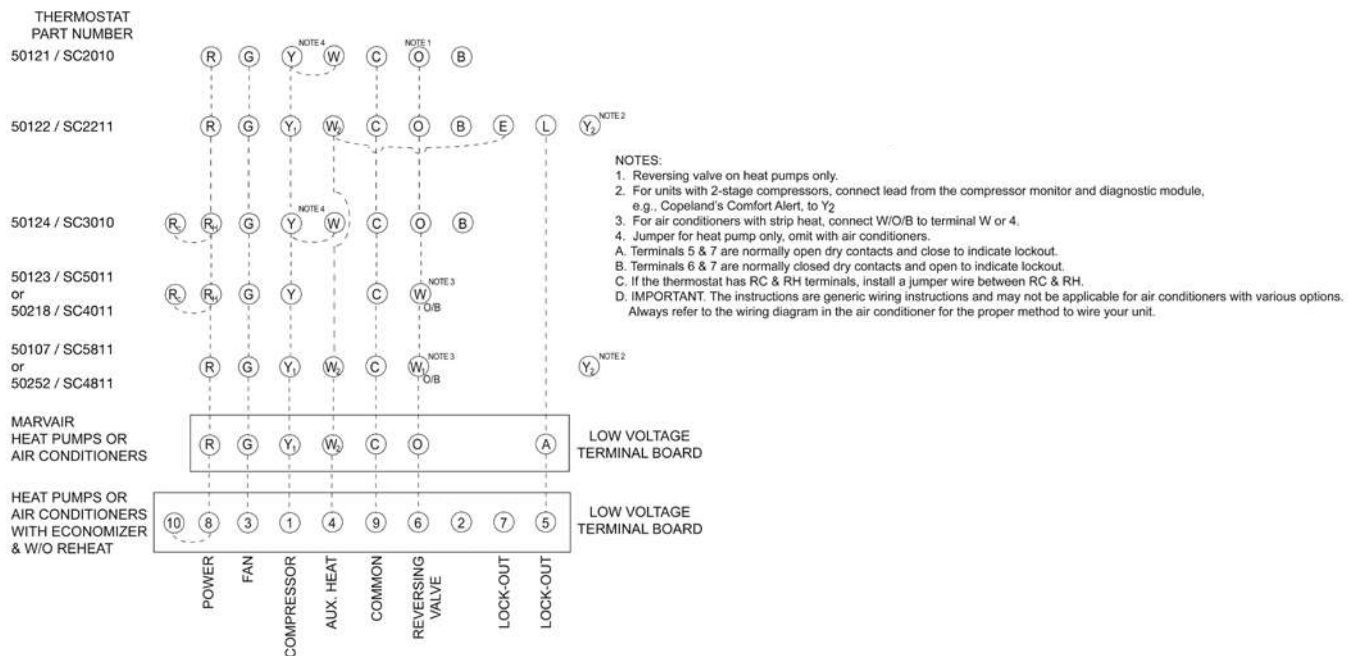

Figure 13b. Thermostat Connection Diagram

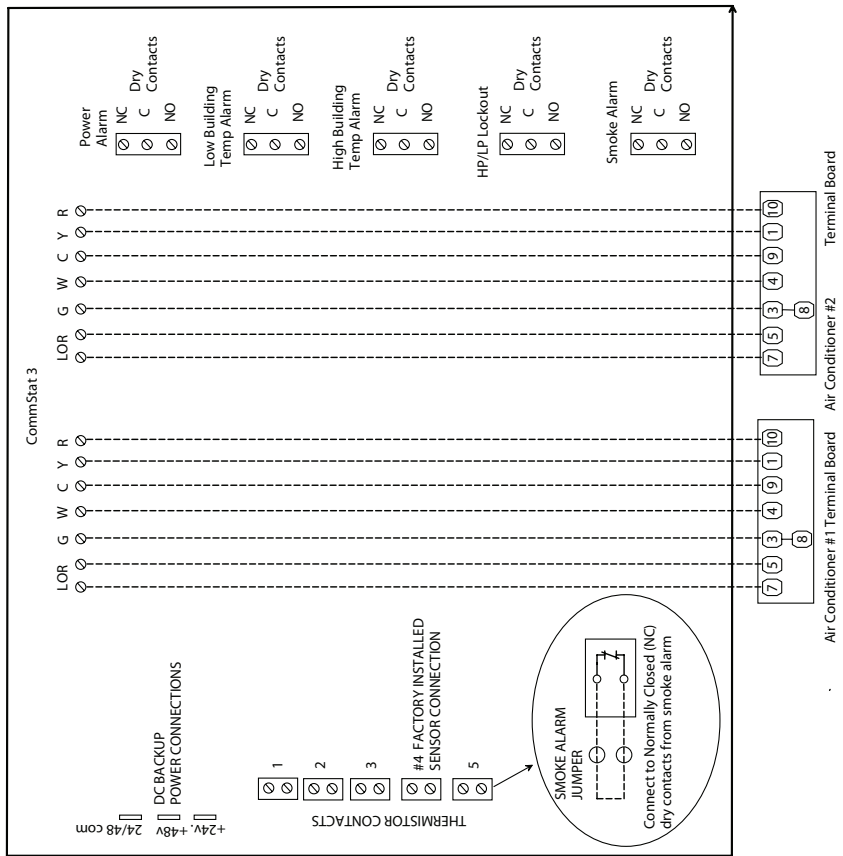

Figure 13c. CommStat 3 Wiring Diagram

NOTE:
1. 24 VAC connections only.

- For immediate shutdown of air conditioner upon a signal from the smoke alarm, the jumper between terminals 8 and 10 in the ComPac® I and ComPac® II units must be removed and a jumper placed from terminals 8 and 3.
- When connecting a smoke alarm to the smoke alarm input terminals (normally closed), remove the factory installed jumper wire and install the smoke alarm leads.

IF LINE VOLTAGE IS BELOW 220 VAC, USE THE 208 TRANSFORMER TAP.

Chapter 4 Start-Up

4.1 Check-Out of Cooling Cycle

Important: Be sure that the crankcase heater (if used) has been energized for at least 24 hours before starting the unit(s). Double-check all electrical connections before applying power. Marvair air conditioners with scroll compressors running on 3Ø power must be checked for proper rotation during the initial start-up. Please refer to Section 2.8 for determining if the 3Ø compressors are rotating correctly. Incorrect rotation can damage the compressor and is not covered by the warranty

Procedure:

1. Set the cooling set point temperature on the wall thermostat to a point *higher* than the ambient temperature. Set the heating set point temperature to a temperature that is *lower* than the ambient.
2. Set the thermostat system switch in the AUTO position. Nothing should operate at this time.
3. Set the time delay in the electrical control box to three minutes. Check the changeover setting of the enthalpy or dry bulb sensor and reset it if needed (economizer-equipped models only). See Section 1.6.
4. Slowly lower the thermostat's cooling set point temperature until the switch closes. The indoor fan should operate.

Once the indoor fan turns on, allow approximately three minutes for the compressor to start. Note that the outdoor fan may not come on immediately, because it is cycled by refrigerant pressures.

NOTE: (Economizer-Equipped models only) To check the system operation under different ambient conditions, the air temperature and enthalpy sensors must be "tricked". When outdoor ambient conditions are higher than the control setting, a component cooler aerosol may be sprayed directly into the enthalpy sensor to simulate low enthalpy conditions, causing the economizer damper to open.

Alternately, when outdoor conditions are lower than the set point, a source of heat such as a hair dryer can be directed on the air temperature sensor to simulate warmer conditions, which will bring on mechanical cooling and start the compressor.

5. To stop cooling, slowly raise the thermostat cooling set point to a temperature higher than the ambient.

If the unit fails to operate, refer to the troubleshooting information in Chapter 4.

Follow the same procedure for additional units.

NOTE: The fan purge allows the indoor fan to run for approximately 90 seconds after the compressor is off. This operation provides a small improvement in system rated efficiency.

4.2 Check-Out of Heating Cycle

Procedure: (Applies only to units with resistance elements)

1. Raise the heating set point temperature to a setting which is higher than the ambient temperature. The fan and electric heat should immediately cycle on.
2. Move the system switch to the "OFF" position. All functions should stop.

NOTE: (Economizer Equipped models only) The damper blade should remain closed during the heating cycle (unless the minimum position potentiometer has been set for constant ventilation A fully counterclockwise position corresponds to full closure of the damper.

Chapter 5 Troubleshooting

5.1 Overview

A comprehensive understanding of the operation of the air conditioner is a prerequisite to troubleshooting. Please read the Chapter 1 for basic information about the unit.

Marvair air conditioners are thoroughly tested before they are shipped from the factory. Although unlikely, it is possible that a defect may escape undetected, or damage may have occurred during transportation. However, the great majority of problems result from installation errors.

If you experience difficulties with your unit, please review the installation steps in Chapter 2.

Much time can be saved by taking a thoughtful and orderly approach to troubleshooting. Start with a visual check - are there loose wires, crimped tubing, missing parts, etc? Begin deeper analysis only after making this initial inspection.

The troubleshooting information in this manual is basic. The troubleshooting section contains problem/solution charts for general problems, followed by a compressor section.

Not every problem can be anticipated. If you discover a problem that is not covered in this manual, we would be very grateful if you would bring it to the attention of our service department for incorporation in future revisions.

As always, please exercise caution and good judgement when servicing the unit. Use only safe and proven service techniques. Use refrigeration goggles when servicing the refrigeration circuit.

WARNING

The refrigerant circuit has hot surfaces, and the electrical voltages inside of the unit may be hazardous or lethal. SERVICE MAY BE PERFORMED ONLY BY QUALIFIED AND EXPERIENCED PERSONS.

5.2 Failure Symptoms Guide

PROBLEM/SYMPTOM	LIKELY CAUSE(S)	CORRECTION
<p>A. Unit does not run.</p> <p>NOTE: An internal anti-short-cycle timer will prevent the unit from starting for .2 to 8 minutes following start-up.</p>	<ol style="list-style-type: none"> 1. Power supply problem. 2. Tripped internal disconnect. 3. Shut off by external thermostat or thermostat is defective. 4. Unit off on high or low pressure limit. 5. Internal component or connection failure. 	<ol style="list-style-type: none"> 1. Check power supply for adequate phase and voltage. Check wiring to unit and external breakers or fuses. 2. Check internal circuit protection devices for continuity. 3. Check operation of wall-mounted thermostat. 4. Reset pressure switch. 5. Check for loose wiring. Check components for failure.
<p>B. Unit runs for long periods or continuously; cooling is insufficient.</p>	<ol style="list-style-type: none"> 1. Dirty filter or reduced airflow 2. Low refrigerant. 3. Component failure. 4. Unit undersized for job. 	<ol style="list-style-type: none"> 1. Check air filter(s). Check blower operation. Remove airflow restriction. 2. Check for proper charge and possible refrigerant leak. 3. Check internal components, especially compressor for proper operation. 4. Add additional units for greater capacity.
<p>C. Unit cycles on high/low pressure limit.</p>	<ol style="list-style-type: none"> 1. Loss or restriction of airflow. 2. Restriction in refrigerant circuit. 3. Refrigerant overcharge (following field service) 4. Defective pressure control. 	<ol style="list-style-type: none"> 1. Check blower assembly for proper operation. Look for airflow restrictions, e.g., the air filter. Check blower motor and condenser fan. 2. Check for blockage or restriction, especially filter drier and capillary tube assembly. 3. Evacuate and recharge to factory specifications. 4. Check limit cutout pressures. Control is set to actuate at approximately 60 PSIG (low pressure) and 650 PSIG (high pressure)
<p>D. Unit blows fuses or trips circuit breaker.</p>	<ol style="list-style-type: none"> 1. Inadequate circuit ampacity. 2. Short, loose, or improper connection in field wiring. 3. Internal short circuit. Loose or improper connection(s) in unit. 4. Excessively high or low supply voltage or phase loss (3Ø only) 	<ol style="list-style-type: none"> 1. Note electrical requirements in Chapter 2 and correct as necessary. 2. Check field wiring for errors. 3. Check wiring in unit. See wiring and schematic diagrams. Test components (especially the compressor) for shorts. 4. Note voltage range limitations specific to the compressor troubleshooting section.
<p>E. Water on floor near unit.</p>	<ol style="list-style-type: none"> 1. Obstruction in condensate line. 2. Obstruction or leak in condensate pan. 3. Unit is not level. 	<ol style="list-style-type: none"> 1. Check for clog or restriction. 2. Check pan for leak or blockage. 3. Level unit.
<p>F. No space heating or reduced heating (units equipped with resistance elements)</p>	<ol style="list-style-type: none"> 1. Defective heating element(s). 2. Thermal limit open. 3. Defective heater contactor. 	<ol style="list-style-type: none"> 1. Check resistance element(s) for continuity. 2. Check continuity across thermal limit switch. 3. Check relay for proper operation. Replace if defective.

5.3 Compressor Troubleshooting

NOTE: It is important to rule out other component failures before condemning the compressor.

The following electrical tests will aid diagnosis:

1. **Start-Up Voltage:** Measure the voltage at the compressor contactor during start-up. The voltage must exceed the minimum shown in Table 5, section 2.2, or compressor failure is likely. A low voltage condition must be corrected.
2. **Running Amperage:** Connect a clip-on type ammeter to the (common) lead to the compressor. Turn on the supply voltage and energize the unit. The compressor will initially draw high amperage; it should soon drop to the RLA value or less. If the amperage stays high, check the motor winding resistances.

NOTE: Feel the top of the compressor to see if it has overheated. If it is hot, the internal overload may be open. You may have to wait several hours for it to reset.

3. **Motor Winding Resistances:** Using a digital volt-ohm meter (VOM), measure the resistance across the compressor windings as shown below.

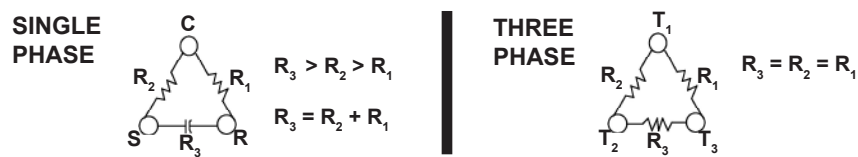

Resistance can be measured as shown above. Any deviation from above values could indicate a defective compressor.

4. **High Voltage/Insulation Test:** Test internal leakage with a megohmmeter. Attach one lead to the compressor case on a bare metal tube and to each compressor terminal to test the motor windings. A short circuit at high voltages indicates a motor defect. Do not do this test under vacuum.
5. On single phase models, check the capacitor by substitution.

5.4 Control Board Diagnosis

The control board (see section 1.6a for a complete description of the control board) has a red diagnostic LED which indicates the lockout fault. The control board will enter into and indicate lockout if either of the fault conditions (LPS or HPS) occur twice.

The contactor must be closed before the first fault condition can be recognized by the control board. The contactor will be closed 3 minutes after the unit is energized and only if cooling is required. The first fault condition will open the contactor and shutdown the unit. The contactor on the unit that has the fault condition must be closed before the second fault condition can be recognized by the control board. The contactor on the unit with the fault condition will close after 3 minutes if the unit is still calling for cooling and if the fault condition no longer exists. If you get a second fault condition, the contactor will open and shutdown the unit. The “red” led will have one blink if the high pressure switch has opened twice and will have two blinks if the low pressure switch has opened twice. The unit must be in the cooling mode (compressor contactor Closed) before a fault condition can occur.

Chapter 6 Maintenance

6.1 Scheduled Maintenance

Airxcel Commercial Group strongly recommends that the air conditioner be serviced a minimum of twice a year – once prior to the heating season and once prior to the cooling season. At this time the filters, evaporator coil, condenser coil, the cabinet, and condensate drains should be serviced as described below. Also at this time, the air conditioner should be operated in the cooling and heating cycles as described in Chapter 3, Start-Up. In addition to this seasonal check-out, the AC unit should be maintained as follows:

Air Filter

Replace the air filter whenever it is visibly dirty. Never operate the unit without the filter in place.

Evaporator

If the evaporator becomes clogged or dirty, it may be cleaned by careful vacuuming or with a commercial evaporator cleaning spray. DO NOT use a solvent containing bleach, acetone, or flammable substances. Turn off power before cleaning. Be careful not to wet any of the electrical components. Be sure the unit has dried before restarting.

Condenser

Periodically inspect the outdoor condenser coil and the cabinet air reliefs for dirt or obstructions. Remove foreign objects such as leaves, paper, etc.

If the condenser coil is dirty, it may be washed off with a commercial solvent intended for this purpose. **TURN OFF POWER BEFORE CLEANING!** Be sure that all electrical components are thoroughly dry before restoring power. Use a fin comb of the correct spacing to straighten mashed or bent fins.

Cabinet

The cabinet may be cleaned with a sponge and warm, soapy water or a mild detergent. Do not use bleach, abrasive chemicals or harmful solvents.

Drains

Regularly check the primary and secondary condensate drains. The secondary drain has a stand pipe. An obstruction will force water to dump into the middle of the unit and drain out the sides of the unit, causing discoloration of the side panels. If discoloration is noted, service the drains.

If a commercial drain solvent is used, flush out the drain pan and system with plenty of fresh water to prevent corrosion.

Lubrication

Oiling of the condenser fan motor or the evaporator blower motor is not recommended.



Sever hazard. The economizer contains moving parts capable of causing serious injury or death. Disconnect power before removing the covering panel.

Chapter 7 Warranty

7.1 Marvair, Inc. Limited Product Warranty

Marvair Inc., warrants its products to be free from defects in materials and workmanship under normal use to the original purchaser for the period of time in the table below. If any part of your product fails within 12 months from start-up, or 18 months from shipment from the factory, whichever comes first, Marvair, Inc. will furnish without charge, EXW Cordele, Georgia, the required replacement part. The owner must provide proof of the date of the original start-up. The contractor's invoice, the certificate of occupancy, or similar documents are examples of acceptable proof of the date of the original start-up.

Marvair, ICE, Eubank Products
90 Days ¹ w/Flat Rate Labor ² (See Marvair, ICE, Eubank Flat Rate Labor Guidelines)
1 Year Parts ^{2,3}
5 Years Compressor ²

¹If any part of your Marvair, Inc. unit fails within 90 days of the commencement of the warranty, Marvair, Inc. will furnish without charge, EX Works, Cordele, Georgia, the required replacement part and pay for the labor to replace the part in accordance with the Marvair, Inc. Flat Rate Labor Guidelines.

²All OTR (over the road) applications that are moved from one location to another: Factory Warranty applies only up to the point of initial start-up and test at all OEM manufacturing locations or subsequent facility. Once it goes into OTR service, the warranty expires immediately for compressor and sealed system components. This OTR exemption does not apply to relocatable classrooms, construction or office trailers.

³All warranty replacement parts shall be shipped Ground only. Expedited shipping is available upon request for additional cost.

The responsibility of the equipment owner includes:

1. To operate the equipment in accordance with the manufacturer's instructions.
2. To provide easy accessibility for servicing.
3. To check and reset any circuit breaker(s) and/or disconnect(s) prior to calling for service.
4. To keep the unit clean and free of dirt and containment and replace filters as required.
5. To keep the outdoor coil clean and free of leaves, paper, or other debris.
6. To pay the charges incurred when any of the above have not been done.
7. To pay for repair or replacement of any material or part other than those within the Marvair unit or controller.

Marvair, Inc., will not be responsible for labor after 90 days, transportation costs, delays or failures to complete repairs caused by events beyond our control (labor hours incurred due to required site-specific training, time waiting to gain access, or extended drive time for remote sites). This warranty does not cover:

1. Any transportation, related service labor, diagnosis calls, filter, driers, refrigerant, or any other material charges.
2. Damages caused by shipping, accident, abuse, negligence, misuse, fire, flood, or Acts of God.
3. Damages caused by operating or staging the unit in a corrosive environment.
4. Damages caused by improper application of the product.
5. Damages caused by failing to perform proper routine maintenance.
6. Expenses incurred for erecting, disconnecting or dismantling the product or installing the replacement part(s).
7. Products not installed or operated according to the included instructions, local codes, and good trade practices.
8. Products moved from the original installation site.
9. Products lost or stolen
10. Consequential damages or incidental expenses including losses to persons, property or business.
11. Modifications to original unit after it leaves the factory, such as breaking into any part of the sealed systems unless authorized in advance in writing by Marvair, Inc..
12. Damages as a result of operating as a construction site cooler / dehumidifier.

When labor (first 90 days only) is required, it must be performed during normal working hours (8:00 AM - 5:00 PM) Monday - Friday and must be performed by Marvair, Inc., personnel or a designated Service Representative.

The owner of the product may ship the allegedly defective or malfunctioning product or part to Marvair, Inc., at such owner's expense, and Marvair, Inc., will diagnose the defect and, if the defect is covered under this warranty, Marvair, Inc., will honor its warranty and furnish the required replacement part. All costs for shipment and risk of loss during shipment of the product to Marvair, Inc., and back to the owner shall be the responsibility and liability of the owner. Upon written request by an owner, Marvair, Inc., may arrange for remote diagnosis of the allegedly defective or malfunctioning product or part but all costs for transportation, lodging and related expenses with regard to such diagnostic services shall be the responsibility and liability of the owner.

An owner requesting performance under this Warranty shall provide reasonable access to the allegedly defective or malfunctioning product or part to Marvair, Inc., and its authorized agents and employees.

THIS WARRANTY CONSTITUTES THE EXCLUSIVE REMEDY OF ANY PURCHASER OF A MARVAIR HEAT PUMP OR AIR CONDITIONER AND IS IN LIEU OF ALL OTHER WARRANTIES, EXPRESSED OR IMPLIED, INCLUDING, WITHOUT LIMITATION, ANY IMPLIED WARRANTY OF MERCHANTABILITY OR FITNESS FOR USE, TO THE FULLEST EXTENT PERMITTED BY LAW. IN NO EVENT SHALL ANY IMPLIED WARRANTY OF MERCHANTABILITY OR FITNESS FOR USE EXCEED THE TERMS OF THE APPLICABLE WARRANTY STATED ABOVE AND MARVAIR SHALL HAVE NO OTHER OBLIGATION OR LIABILITY. IN NO EVENT SHALL MARVAIR BE LIABLE FOR INCIDENTAL OR CONSEQUENTIAL DAMAGES OR MONETARY DAMAGES.

THIS WARRANTY GIVES YOU SPECIFIC LEGAL RIGHTS, AND YOU MAY ALSO HAVE OTHER RIGHTS WHICH VARY FROM STATE-TO-STATE. Some states do not allow limitations or exclusions, so the above limitations and exclusions may not apply to you.

Chapter 8 Start-Up Check List

8.1 Start-Up & Commissioning Form

Please complete the information on this form and return to Marvair by mail or fax. The mailing address and fax number can be found at the end of the form.

A. Equipment Information

Date: _____ Equipment Owner _____

Installing Company: _____ Installer: _____

Address: _____ State _____

City: _____

ICE Air conditioner: Model No. _____

Serial No. _____

Compressor: Model No. _____

Serial No. _____

Compressor: Model No. _____

Serial No. _____

B. Pre-Start Up

Is there any shipping damage? Yes No

If so, where? _____

Will this damage prevent starting the unit? Yes No

Check Power Supply, does it agree with data sticker on air conditioner? Yes No

Has the ground wire been connected? Yes No

Has the circuit protection been sized and installed properly? Yes No

Controls

Are the thermostat control wiring connections made and checked? Yes No

Are all wiring terminals (including main power supply) tight? Yes No

If unit has a crankcase heater, has it been energized for 24 hours? Yes No

On a 208/230 v. units is control transformer (24 AC) wired for correct voltage? Yes No

Condensate Section

Has water been placed in drain pan to confirm proper drainage? Yes No

Are correct filters in place? Yes No

Refrigerant Piping

If leaks are found, report any leaks to ICE Warranty Service Dept.

C. Check Rated Voltage at Terminal Block for Imbalance before starting of Unit.

208/230V 1 Phase

208/230V 3 Phase

460V 3 Phase

380V 3 Phase 50Hz.

575 3 Phase 60 Hz.

Measured Line to Line Volts L1&L2 _____ V. L1&L3 _____ V. L2&L3 _____ V.

$(L1\&L2 + L1\&L3 + L2\&L3)/3 = \text{Avg. Voltage} = \underline{\hspace{2cm}}$

Max. Deviation from avg. voltage = _____ volts

Voltage imbalance = $(100 \times \text{Max. Deviation})/\text{avg. Voltage} = \underline{\hspace{2cm}}\%$

A voltage deviation greater than 2% with the unit running should be addressed and corrected. Excess voltage deviation can cause the compressor to overheat and to operate inefficiently.

Example:
$$\frac{\text{Maximum Deviation from Average Voltage} \times 100}{\text{Average voltage}} \text{ (for Percent)}$$

Measured Voltages:

L1 & L2 = 241 Volts

L1 & L3 = 243 Volts = $717 / 3 = 239$ Average Voltage

L2 & L3 = 233 Volts

$239 - 233 = 6$

$100 \times 6/239 = 2.5\%$ Voltage Unbalance

Three phase units only check fan & compressor rotation.

D. Heating Mode Check & Record Readings

	Circuit 1	Circuit 2 <i>(if applicable)</i>
Room Temperature	_____	_____
Outside Temperature	_____	_____
Evap. Entering Air DB Temp	_____	_____
Evap. Entering Air WB Temp	_____	_____
Evap. Leaving Air DB Temp	_____	_____
Evap. Leaving Air WB Temp	_____	_____
Heater Contactor Amps (L1)	_____	_____
Heater Contactor Amps (L2)	_____	_____
Heater Contactor Amps (L3)	_____	_____

E. Cooling Mode Check & Record Refrigerant Pressures

Recheck voltage imbalance in cooling mode:

Measured Line to Line Volts L1&L2 _____ V. L1&L3 _____ V. L2&L3 _____ V.

$(L1\&L2 + L1\&L3 + L2\&L3)/3 = \text{Avg. Voltage} = \underline{\hspace{2cm}}$

Max. Deviation from avg. voltage = _____ volts

Voltage imbalance = $(100 \times \text{Max. Deviation})/\text{avg. Voltage} = \underline{\hspace{2cm}}\%$

After 10 minutes of compressor operation, record the following:

	Circuit 1	Circuit 2 <i>(if applicable)</i>
Room Temperature	_____	_____
Outside Temperature	_____	_____
Suction Pressure	_____	_____
Suction Line Temperature	_____	_____
Discharge Pressure	_____	_____
Discharge Line Temperature	_____	_____
Entering Condenser Air	_____	_____
Leaving Condenser Air	_____	_____
Evap. Entering Air DB Temp	_____	_____
Evap. Entering Air WB Temp	_____	_____
Evap. Leaving Air DB Temp	_____	_____
Evap. Leaving Air WB Temp	_____	_____
Compressor Amps (L1)	_____	_____
Compressor Amps (L2)	_____	_____
Compressor Amps (L3)	_____	_____

Notes:

APPENDIX A: Installation Instructions for Field Installed Electric Heat, Models 1024-1072

WARNING **FIRE HAZARD**

Improper adjustment, alteration, service, maintenance or installation could cause serious injury, death and/or property damage.

Installation or repairs made by unqualified persons could result in hazards to you and others. Installation **MUST** conform with local codes or, in the absence of local codes, with codes of all governmental authorities have jurisdiction.

The information contained in this manual is intended for use by a qualified service agency that is experienced in such work, is familiar with all precautions and safety procedures required in such work, and is equipped with the proper tools and test instruments.

Duct Work

General Information

Note: The following instructions are for general guidance only. Due to the wide variety of installation possibilities, specific instructions will not be given. When in doubt, follow standard and accepted installation practices, or contact Airxcel Commercial Group for additional assistance.

Wall Openings

Measure the dimensions of the supply and return ports on the unit.

Cut the openings in the exterior wall for the supply and return. **IMPORTANT: All units with electric heat must have 1" (25.4 mm) clearance on all four sides of the supply outlet duct flange on the unit. The 1" (25.4 mm) clearance must extend on all sides of the supply duct for the first 3 feet (1 meter) from the unit.**

IMPORTANT: Marvair requires a minimum of 1" (25.4 mm) from the surface of any supply ducts to combustible material for the first 3 feet (1 meter) of the duct.

Ducting

Extensions should be cut flush with the inside wall for applications without duct work.

Applications using duct work should be designed and installed in accordance with all applicable safety codes and standards. Marvair strongly recommends referring to the current edition of the National Fire Protection Association Standards 90A and 90B before designing and installing duct work. The duct system must be engineered to insure sufficient air flow through the unit to prevent over-heating of the heater element. This includes proper supply duct sizing, sufficient quantity of supply registers, adequate return and filter area. Ductwork must be of correct material and must be properly insulated. Duct work must be constructed of galvanized steel with a minimum thickness of .019 inches for the first 3 feet (1 meter). Ductwork must be firmly attached, secured and sealed to prevent air leakage. Do not use duct liner on inside of supply duct within 4 feet (122 cm) of the unit. Galvanized metal duct extensions should be used to simplify connections to duct work and grilles. Use fabric boots to prevent the transmission of vibration through the duct system. The fabric must be U.L. rated to a minimum of 197°F (92°C).

 **WARNING**

ELECTRICAL SHOCK HAZARD

Failure to follow safety warnings exactly could result in serious injury, death, and/or property damage.

Turn off electrical power at fuse box or service panel BEFORE making any electrical connections and ensure a proper ground connection is made before connecting line voltage.

Heater installation (see drawings and wiring diagram)

1. Remove top front panel.
2. Remove bottom front panel.
3. Remove the control box cover.
4. Remove the heater access cover plate on the upper right side of the unit by removing the three screws. Cut insulation on two sides and fold down out of way.
5. Slide new heater assembly into place by lining up stem with hole on far end. Make sure stem of new heater assembly is inserted into correct hole. The hole nearest to the indoor coil is for three element heaters and the farthest away from indoor coil is for all other heaters.
6. Install the two No. 10 screws in the heater assembly plate.
7. Install wire harness in hole provided in drain pan and then through filter bracket and then into control box.
8. Wire the heater as shown in the wiring diagram provided with the heater kit (the insulated terminal ends are to be connected at the heater)
9. Install pop tie in appropriate hole in back panel to secure wire.
10. Install closed cell strip around wires where they pass through the drain pan.
11. Reinstall the heater access cover.
12. Mount the heat contactor inside the control box where the mounting holes are provided for the heat contactor.
13. Make the wiring connections inside the control box as shown in the wiring diagram provided with the heater kit. Bundle loose wires with wire ties.
14. With a permanent marker, place an (X) in the space provided next to the heater kit rating of the installed heater on the unit data label.
15. Place the wiring diagram provided with the heater kit inside the zip lock bag which is affixed to the back side of the control box cover.
16. Replace the control box cover, the bottom front cover and the top front panel.

